

AZERBAIJAN REPUBLIC



**AZERBAIJAN RAILWAYS
CLOSED JOINT – STOCK COMPANY**

BIDDING DOCUMENTS

**Procurement of
Design, Supply and Installation Works for Rail
Track Rehabilitation (Including Structures) of
Yalama- Sumgait Line**

VOLUME II

Employer's Requirements (ERQ)

**Lot 1:
Sumgait (Km 2622+175) to
Gil-Gil-Chay Station (Km 2538+200)**

Issued on: **24 December 2018**
Invitation for Bids No.: **RSDP – Lot 1 & 2**
ICB No.: **RSDP – Lot 1 & 2**

Section 6 - Employer's Requirements

Lot 1 – From Sumgayit (km 2622,175 approximately) to Gil-Gil-Chay Station (km 2538,200, approximately).

This Section contains the Specifications, Supplementary Information that describe the Works to be procured, Personnel Requirements, and Equipment Requirements.

Note: Supplementary Information regarding Works to be procured

- Land Acquisition and Resettlement Plan – Appendix 25 of the Employer's Requirements (Soft copy of Appendix 25 is provided in DVD for Lot 1).
- The Initial Environmental Examination (IEE) – Appendix 26 of the Employer's Requirements (Soft copy of Appendix 26 is provided in DVD for Lot 1).

(Note: The IEE Report is currently being updated by ADY to reflect potential contamination issues and will be re-issued to bidders during the bid preparation period.)

Table of Contents

Part 1 –	Technical Specifications – General.....	6-3
Part 2 –	Technical Specifications – Functional.....	6-25
Part 3 –	Technical Specifications - Design of Civil and Track.....	6-35
Part 4 –	Technical Specifications - Construction Site Requirement.....	6-102
Part 5 –	Technical Specifications - Manufacture, Supply, Installation, Testing and Commissioning.....	6-137

APPENDICES.....6-155

Appendix 1–	General Arrangements & Materials.....	6-156
Appendix 2 –	Schedule of Dates & Milestones.....	6-202
Appendix 3 –	Design and Construction Interfaces.....	6-208
Appendix 4 –	Programme Requirements.....	6-213
Appendix 5 –	Monthly Progress Report.....	6-222
Appendix 6 –	Quality Assurance.....	6-226
Appendix 7 –	Drawings and CAD Standard.....	6-229
Appendix 8 –	Site and Temporary Power Supply.....	6-237
Appendix 9 –	Project Calendar.....	6-242
Appendix 10 –	First Aid Base.....	6-244
Appendix 11 –	Level Crossings, Animal Crossings, Pedestrian Crossings, Fencing.....	6-246
Appendix 12 –	Requirement for the Site Safety Plan.....	6-250
Appendix 13 –	Environmental Protection & Safeguard Requirements.....	6-256
Appendix 14 –	Reliability, Availability, Maintainability & Safety (RAMS)....	6-270
Appendix 15 –	Possession Management.....	6-275
Appendix 16 –	Standards and Codes for Civil & Tracks.....	6-278
Appendix 17 –	Historic Train Operation Data.....	6-285
Appendix 18 –	Facilities for the Engineer.....	6-290
Appendix 19 –	Certificates.....	6-297
Appendix 20 –	Bridges & Structures.....	6-300
Appendix 21 –	Personnel Requirements.....	6-314
Appendix 22 –	Equipment Requirements.....	6-316
Appendix 23 –	Track Signage Requirement.....	6-318
Appendix 24 –	Engineering Design Assurance - Gate Procedure.....	6-323
Appendix 25 -	Supplementary Information - Land Acquisition and Resettlement Plan.....	6-330
Appendix 26 –	Supplementary Information – Initial Environmental Examination (IEE) Report.....	6-331
Attachment 1 –	Level Crossings	
Attachment 2 –	Animal Crossings	
Attachment 3 –	Bridge Details	
Attachment 4 –	Culvert Details	

PART 1 –

TECHNICAL SPECIFICATIONS – GENERAL

1 INTRODUCTION

1.1 General

The Rail transport in Azerbaijan is operated by the national state-owned railway company *Azərbaycan Dəmir Yolları* (ADY), and the double track from Sumqayıt to Yalama (Russian Border) is to be rehabilitated and capable of operation at a maximum operational train speed of 140 km/hr for conventional passenger train and 80 km/hr for freight trains, using the existing Signalling System and the Electrification with 3 kV – DC.

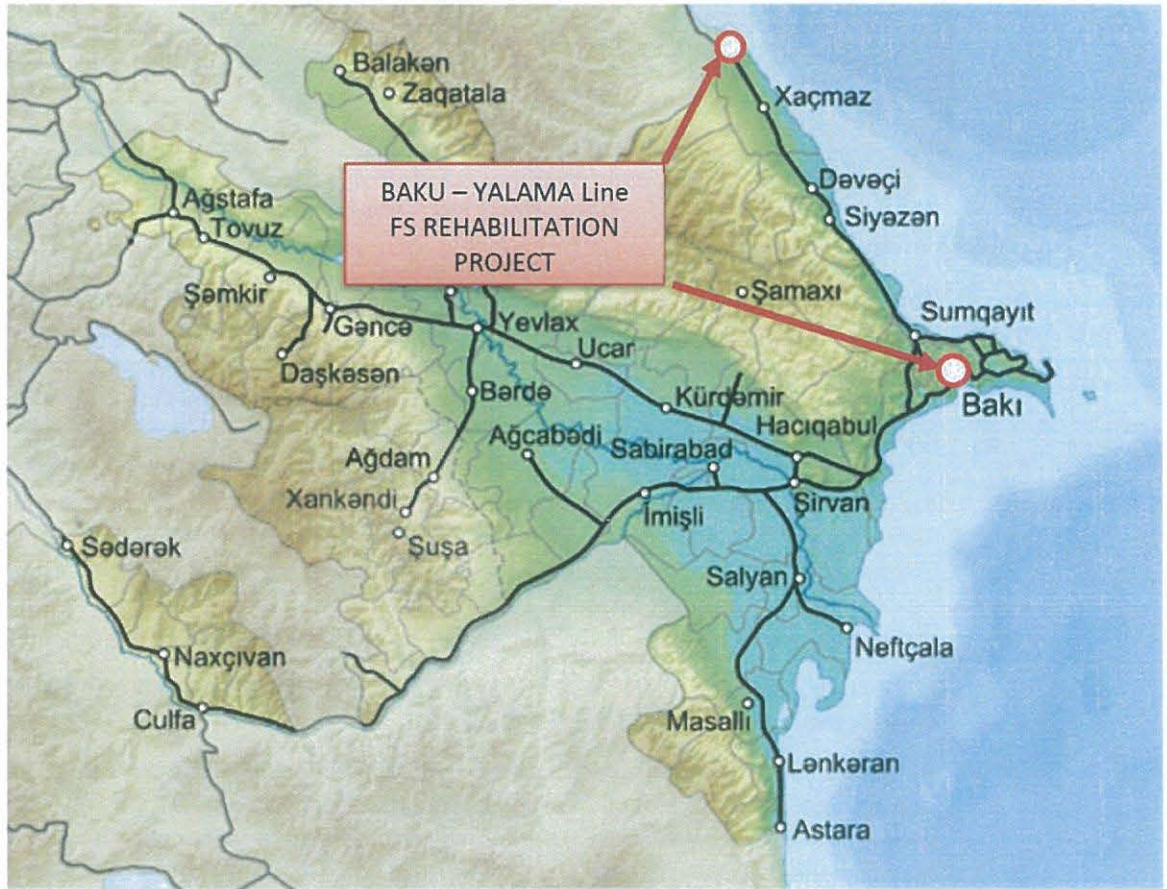

Location Map – Lot 1 and Lot 2

The Track Rehabilitation Project is divided into two contract lots – Lot 1 is this Contract and Lot 2 is the adjacent contract.

Lot 1 location is set out in the table below:

LOT 1 – Between SUMGAYIT and GIL-GIL-CHAY Stations (Inclusive)	
From	To
2622 km + 175m	2538 km + 200m

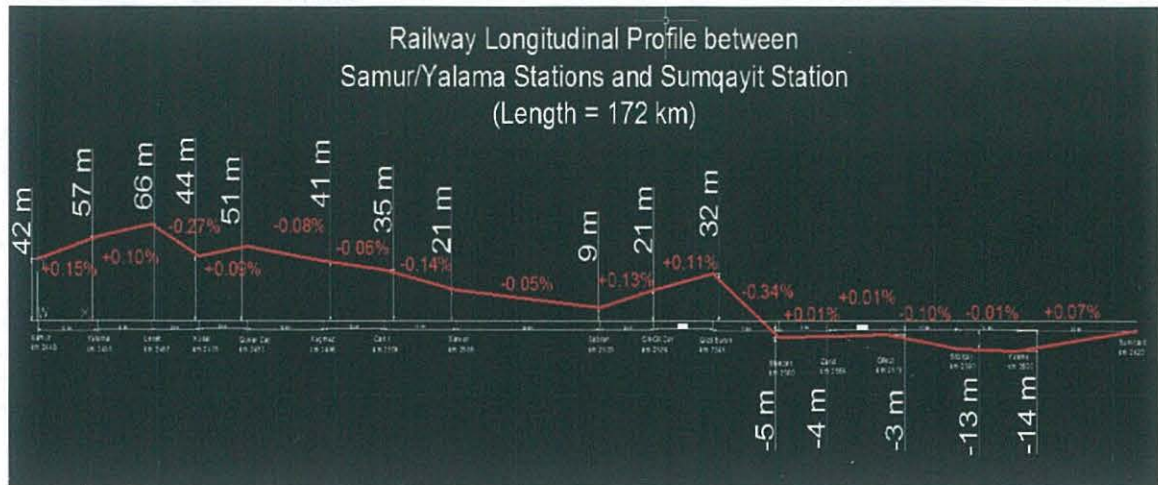

Track Elevation – Lot 1 and Lot 2

1.2 Existing Track System

The ADY track between Sumgayit and Gil-Gil-Chay is double track (Tracks 1 & 2) with R-65 rail. The track type varies from timber sleepers with anchors and dogspikes, to a mix of timber sleepers interspersed with pre-stressed monoblock concrete sleepers, and track that is fully pre-stressed monoblock concrete sleepers. Short lengths of track are pre-stressed monoblock concrete sleepers with timber sleepers inserted under joints. Some track is made up of short length 25 m rails un-welded, while other parts are long-welded rail into lengths up to 800m. Sleepers are spaced nominally at 1840 sleepers per km. On concrete sleepers the fastening is a resilient fastener using screws, springs, insulators and pad. There is nominally 350mm of ballast below the sleeper, however much of the ballast has been degraded and heavily fouled. The track gauge is 1520mm. All existing turnouts are un-welded, and set on timber bearers. A number of turnouts and crossovers are included on Tracks 1 & 2.

In the section Sumgayit and Gil-Gil-Chay there are nine (9) stations with a distance between stations averaging approximately 10km.

At the stations there are numerous track sidings connected to Tracks 3 & 4. The sidings provide access to the industrial sidings, wagon stabling, as well as loading and unloading areas. At Haci Zeynalabdin Tagiyev station there is a connection to the locomotive maintenance facility.

Between Sumgayit and Gil-Gil-Chay there are 10 level crossings to be rehabilitated. On the level crossings the track geometry is generally in poor condition, and there are broken track component. Generally it is not possible to tamp thru the level crossings due to the track and crossing condition, as well as the lack of ballast. The level crossings shall be upgraded so it is possible to remove panels to permit tamping

Track alignment is mostly straight with some easy curves $R > 1000m$ and a small number of sharper curves approximately $R300m$. Gradient is as per the details shown in the track elevation diagram above. There are many locations where the alignment of the track has been deviated over short distances to accommodate bridges or culverts, station platforms, or for reasons unknown. At these locations realignment is required to eliminate (or reduce) the track deviation.

The present quality of much of the tracks is poor, with degraded level and alignment, and broken and/or missing track components. There are speed restrictions as low as 25km/hr whilst other sections of the track are in reasonable condition with speeds up to 100km/hr.

There are many bridges, culverts and other waterway structures on the line. Many of these are in poor condition and need replacement, refurbishment and repair. A number of bridges have guard rails.

The average speed for passenger trains is less than 40km/hr and for freight trains approximately 25 to 30km/hr.

1.3 Existing Electrification System

Traction Power: The Yalama line, from Bilajari to the Russian border the electric traction is 3 kV DC distributed through 10 traction substations with an outgoing voltage of 3 kV. The Russian ongoing line is fed in 3 kV DC for about 40 km and then is fed in 25 kV AC 50 Hz.

All traction substations were built in 1970 to 1973 and these are still in use. Most of them are close to the tracks, with the exception of Bilajari substation which is within a residential area.

OCS: (Overhead Catenary system), for the Yalama line only, was designed to feed the line in 25 kV AC. The Yalama line was supposed to be converted to 25 kV AC feeding system around year 2000, as the whole Azerbaijan and Georgian railway networks, but this did not occur.

During the track rehabilitation works it is proposed to change the existing traction power supply from 3 kV DC to a 25 kV AC 50 Hz system. These works are undertaken by ADY under a different contract. The co-ordination of access, technical and timely interfaces with ADY and the other contractor(s) related to the interface between this Civil & Track Work Rehabilitation Contract and the change of the power supply system are the responsibility of the Contractor.

1.4 Existing Signalling and Telecommunication System:

The existing signalling installations and telecommunication system are approximately 50 years old and based on the use of mechanical relays and track circuits. The signalling installations are controlled locally in each station from a control panel. There are numerous connections to the rail to transmit the signalling information. The Contractor is responsible for ensuring the signalling system is not damaged and any restoration work required on the signalling system due to the track rehabilitation works is the responsibility of the Contractor, and any replacements shall be on a like-for-like basis. The ADY Signalling Maintenance personnel are available to provide attendance for disconnection/reconnection of the signalling system, provided this attendance is fully planned and co-ordinated.

On completion of the track rehabilitation, the Contractor shall be responsible and accountable to ensure the existing signalling system shall be safely operating to the same level of service as before track rehabilitation works commenced.

This Employers Requirements covers Lot 1 only; comprising the civil and track works of the section of the double track from Sumqayit and Gil-Gil-Chay stations.

1.5 Overview of Rehabilitation Works

The total track work scheme includes upgrading of the railway alignment, track formation and its infrastructure to accommodate maximum train speeds of 140 km/hr (+14 km/hr for max line design speed = 154km/hr) for conventional trains on Track N°1 and Track N°2. The required Civil and Track Works for upgrading the railway line have to be undertaken in phases, subsections and sections to permit continuing train operations during the Works. It will be permitted to close one track and operate the remaining track as bi-directional operation for the various phases and sections being worked upon, provided safety and operational issues are appropriately planned, approved by ADY and the Engineer, and then implemented. The phases and sections are to be planned and agreed with ADY, the Engineer, and concerned

stakeholders, and shall comply with the milestones set out in the Contract– See **Appendix 2** – Schedule of Dates & Milestones.

The design of all the works will be produced by the Contractor to support the ADY operating requirements and will follow the specifications defined.

1.6 Structure of Technical Specifications

These Employer's Requirements are divided into five (5) Technical Specification Parts as follows:

Part 1: General: These requirements apply throughout the Contract.

Part 2: Functional: These include the specific core requirements for the design and performance of the Works.

Part 3: Design of Civil and Track Works: These apply in respect of the stages and duties relating to the design of the Civil, Structures and Permanent Track Works.

Part 4: Construction Site Requirements: These apply in respect of phases, duties and other requirements relating to the construction site for the Works.

Part 5: Manufacture, Installation, Supply, Testing & Commissioning: These apply to the requirements relating to manufacturing, procurement, delivery and installation, testing and commissioning of plant and materials which constitute the Permanent Works.

2 DEFINITIONS AND INTERPRETATIONS

In addition to the words and expressions defined in the Conditions of Contract, the following words and expressions shall have the meaning assigned to them except where the context otherwise requires:

- a) **"ADY"**: means the Employer being *Azərbaycan Dəmir Yolları* with the appropriate functions/authorities.
- b) **"ADY Operations"** means the train control and Freight Dept. of ADY.
- c) **"As-Built Drawings"**: means those drawings produced by the Contractor and endorsed by it as true records of construction of the Permanent Works and which have been agreed with the Engineer and the Azerbaijan relevant authorities.
- d) **"Attendance"**: means the free provision by the Contractor of access to their site and their facilities such as temporary lighting, safety measures, ladders etc. which are available at the site for use by Interfacing Parties.
- e) **"CWR"** means Continuously Welded Rail.
- f) **"Concept Design"** means the submission of Contractor's Documents which comprise the initial stage of the Design Phase.
- g) **"Construction Phase"**: has the meaning identified in Part 4 of this document.
- h) **"Date of Commencement"** means the Contracted date when activities begin.
- i) **"Definitive Design"**: has the meaning identified in Technical Specification Part 3 - Design of Civil and Track Works. It is the final prepared and accepted part of Drawings, documents, standards, and instructions including the above-mentioned Drawings and the Design Manual, which give the abilities for supply, installation, construction and testing. Acceptance and agreement of the Definitive Design by the Engineer and the Azerbaijan relevant authorities is an obligatory condition for the beginning of construction works.
- j) **"Definitive Submission"**: means the submission of Contractor's Documents which comprise the whole or parts of the proposed Definitive Design and for which the Contractor seeks a Notice of No Objection.
- k) **"Design Criteria"**: means those parts of the Design Criteria which relate to design.
- l) **"Design Manual"**: means the manual to be prepared and submitted by the Contractor as part of the Definitive Design and as described above.
- m) **"Design Package"**: has the meaning identified in Technical Specifications Part 3 - Design of Civil and Track Works.
- n) **"Design Phase"**: has the meaning identified in Technical Specification - Part 1 General.
- o) **"Design Reports"** means the specifications prepared by the Contractor which combines the Technical Specifications and those parts of the Contractor's technical proposals which specify standards for design, procurement, manufacture, installation and construction-testing-commissioning which are developed during various Design Stages and fully comply with the Employer's requirements.
- p) **"Installation-Testing-Commissioning Phase"**: has the meaning identified in Technical Specifications Part 1 – General.
- q) **"Left Track"** means the railway track that train traffic generally uses when travelling from the Russian Border towards Baku.
- r) **"MENR"** means the Ministry of Ecology and Natural Resources of the Republic of Azerbaijan.
- s) **"Manufacture and Supply Phase"**: has the meaning identified in Technical Specification Part 1 – General.
- t) **"On-Duty Points"**: On-Duty Points for maintenance of the track infrastructure maintenance
- u) **"Preliminary Design"**: means the submission of Contractor's Documents which comprise the intermediate stage of the Design Phase.
- v) **"Right Track"** means the railway track that train traffic generally uses when travelling from Baku towards the Russian Border.

- w) **"Reference and Documents"**: has the meaning identified in Technical Specification " Part 3 " Design of Civil and Track Works as applicable in respect of which a Notice of No Objection has been issue,
- x) **"Reference Drawings Submission"**: means the submission of Reference Drawings and Documents representing the construction or manufacture elements of the Permanent Works and for which the Contractor seeks a Notice of No Objection,
- y) **"Railway Envelope"**: means the zone or zones within the Works which contain the track, platforms and equipment necessary for the operation of the railway by ADY.
- z) **"Reference and Documents"**: has the meaning identified in Technical Specification " Part 3 " Design of Civil and Track Works as applicable in respect of which a Notice of No Objection has been issue,
- aa) **"Reference Drawings Submission"**: means the submission of Reference Drawings and Documents representing the construction or manufacture elements of the Permanent Works and for which the Contractor seeks a Notice of No Objection,
- bb) **"Right-of-Way (RoW)"** means the ADY land upon which the Yalama line resides and generally extends 25m each side of the centreline of the dual track.
- cc) **"Section"**, means a defined area and length of main line tracks and stations between two defined points.
- dd) **"Station"** means the defined location and tracks where trains stop to pick up passengers and undertake loading and unloading of freight.
- ee) **"Structure Gauge"**, means the profile related to the designed normal coordinated axis of the track into which no part of any structure or fixed equipment may penetrate,
- ff) **"Technical Specification"**: means this document and the other Parts forming the Employer's Requirements.
- gg) **"ToR"** means the Contractor's designed level of the top of the running rails i.e. the running rail. Note that the ToR level may vary for each rail dependent on the cant of the track. In this case the top of rail measurement shall be from each rail and not the average between the two rails.
- hh) **"Track Possession"** means a portion of a railway line (or track) that is temporarily taken out of service for rehabilitation and construction purposes.
- ii) **"Working Drawings"**: comprise the Reference Drawings and such other drawings and documents, such as construction drawings, manufacturing drawings, shop drawings, installation drawings and testing and commissioning documents as are necessary to amplify the Reference Drawings for construction etc. purposes and endorsed, as required, by the Engineer.

3 RELEVANT DOCUMENTS

These documents shall be read in conjunction with the General Conditions of Contract, the Particular Conditions of Contract and any other document forming part of the Contract. This contract shall be fulfilled, managed and commissioned in accordance with the applicable legislation in Azerbaijan and existing international norms such as European standards, UIC Leaflets and other EC documents, as well as, with the specific norms and standards, foreseen in the "Urban Planning and Construction Code of the Republic of Azerbaijan", relevant construction and design normative documents, AzDTN/GOST and SNIP and ADY Regulations and other international standards where appropriate. (See Appendix 16).

4 CIVIL & TRACK WORKS DESIGN AND CONSTRUCTION PHASES

- 4.1 With reference to Sub-Clause 17.3 (g) of the General Conditions of Contract, and for the avoidance of doubt, the Contractor is responsible for the design of the whole of the Works unless both parties agree otherwise.
- 4.2 The Contractor shall carry out all further site, ground and structural investigations necessary for the design of the Permanent Works and to enable the determination of the methods of construction and the nature, extent and design of the temporary works.
- 4.3 Design and rehabilitation Works shall be undertaken by defined Section. There are three (3) Sections per Lot. (Refer to **Appendix 2** for details.)
- 4.4 The Contractor shall execute the Civil, Structural and Track Works in two (2) phases; Phase 1, comprising the submission of the Contractor's Documents, which comprises the Design Phase and Phase 2, the Construction Phase.
- 4.5 The various elements covering a major and distinctive part of the Permanent Works for the Civil, Structural and Track Works include, but are not limited to:
- Survey and Alignment
 - Bridges and Structures
 - Track works
 - Any civil works
 - Drainage & Earthworks
 - Level Crossings and Animal Crossings
 - Fencing
 - Testing & Commissioning
- 4.6 The Design Phase shall begin upon the Date of Commencement. This phase shall include the preparation and submission of design packages for:
- (a) Concept Design;
 - (b) Preliminary Design;
 - (c) Definitive Design & Reference Drawings,
- for all the elements set out above.
- 4.7 The Contractor shall appoint a Design Manager to manage the design and report regularly to the Engineer on the progress of design works.
- 4.8 The Contractor shall appoint an Azeri fluent Design Coordination and Expediting Manager to co-ordinate and expedite the design through the entire approval process.
- 4.9 For each design stage, all design documents shall be progressively passed to the Engineer and stakeholders for approval when satisfactorily completed.
- 4.10 The Engineer will respond within 28 calendar days on the acceptability of the design submission by coding the design as:
- a) Code 1 – No comments
 - b) Code 2 – Issues that must be addressed for approval
 - c) Code 3 – Design is Rejected (with reason.)

- 4.11 On completion of each Design Stage the Contractor shall be required to present the complete design to a Gate Committee chaired by the Engineer and attended by the Client and other stakeholders. The Gate Committee will determine whether the design satisfactorily meets the requirements of that design stage and whether the Contractor can proceed onto the next stage of design/and or procurement and construction.
- 4.12 Details of the process to be followed for preparation, presentation and passing the design stage Gate is set out in the Engineering Design Assurance Gate Procedure, in **Appendix 24**.
- 4.13 As the Design stages for each element progress to completion by passing Azerbaijan Republic agencies approvals and the required Assurance gate, once completed satisfactorily the Engineer will provide a Notice of No Objection for that stage.
- 4.14 The Design Phase will be complete upon the issue of a Notice of No Objection in respect of the comprehensive and complete Definitive Design & Reference Drawings Submission for the whole of the Permanent Works – all design work and Reference Drawings are approved and satisfactorily completed before the Notice of No Objection is issued.
- 4.15 The requirements for the Concept Design, Preliminary Design, Definitive Design and Reference Drawings are stated in Technical Specification Part 3 - Design of Civil and Track Works;
- 4.16 The Construction Phase for the whole or a part of the Permanent Works shall commence immediately upon the issue by the Engineer of a Notice(s) of No Objection, in respect of the relevant Reference Drawings Submission for the various elements of the Permanent Works.
- 4.17 Such Notice(s) of No Objection may be issued by the Engineer in respect of a Reference Drawings Submission covering each element of the Permanent Works.
- 4.18 However, construction shall not commence on any individual element of work until the original copies of the appropriate Working Drawings / Definitive Design for that element of the Permanent Works have been endorsed by the:
 - a) Contractor as "Good for Construction";
 - b) Engineer that he has no objections to the drawing.
 - c) Implementing Agency/PMU on behalf of the Employer that he has no objections to the drawings.
- 4.19 The Construction Phase shall include the completion and submission of the Definitive Design and the preparation and submission of the As-Built Drawings on a progressive basis as the Works are constructed, and other records as required.
- 4.20 Notwithstanding the above, for those elements identified under of the Design of Civil and Track Works, the Construction Phase may commence immediately upon the issue of the Notice of No Objection in respect of the Definitive Design Submission for each element of the Permanent Works.
- 4.21 This Notice of No Objection may be in respect of each such element of the Permanent Works subject to availability of the site in accordance with the agreed programme.

5 CONTRACTOR'S DESIGN REPORTS

- 5.1 In accordance with the provisions set out in the Employer's Requirements, the Contractor shall develop the Design Reports during the design stage and submit progressively from

Concept Design stage, Preliminary Design stage and finally as part of the Definitive Design Submission. When the Design Reports have received a Notice of No Objection from the Engineer they shall become the Definitive Design.

- 5.2 The Design Reports shall be prepared in the style of the three-part format of the as per the applicable norms and standards, foreseen in the “Urban Planning Code and Construction of the Republic of Azerbaijan” and relevant construction and design normative documents.
- 5.3 The Design Reports for the Works shall comply with the Employer’s Requirements, Standards and Design Codes which are in accordance with or defined and listed in the Design Criteria and the outline materials and workmanship specifications if any, contained in the documents of Part 4 - Construction Site Requirements.

6 UNITS OF MEASUREMENT

The Contract shall utilise the SI system of units.

7 WORKS PROGRAMME

- 7.1 The Design Stage and the Key Dates (with Milestones) are as defined in **Appendix 2** and in accordance with the Conditions of Contract.
- 7.2 The Contractor shall prepare and submit its Works Programme and three (3) months rolling programmes as defined in the detailed requirements contained in **Appendix 4**.
- 7.3 In compiling its Works Programme and in all subsequent updating and reporting, the Contractor shall make provision for the time required for co-ordinating and completing the design, interface, construction, procurement, manufacture, supply, installation, as-built drawings and information, testing, commissioning and integrated testing of the Works.
- 7.4 This period shall include but not be limited to design co-ordination periods during which the Contractor shall co-ordinate its design with those of Interfacing Parties, review procedures, determining and complying with the requirements of all Government Departments and obtaining all necessary permits.
- 7.5 This period will include co-ordination with all others whose consent, approvals, permissions, authority or licence is required prior to the execution of any work.
- 7.6 The Works Programme shall take full account of all the stages for the Design Submission Programme.

8 MONITORING OF PROGRESS

- 8.1 The Contractor shall submit to the Engineer a Monthly Progress Report (MPR) as set out in Appendix 5 in both English and Azeri describing the progress and current status of the Works, with progress measured (in days for any delays and percentage for actual progress) against the Contractor’s approved Works Programme, which will be used as a baseline. The MPR shall be provided in both hard and soft copy. See **Appendix 5**.
- 8.2 The MPR shall be submitted no later than the fifth (5th) day of each calendar month and it shall account for all works actually performed from the 26th day to the 25th day of the previous period.
- 8.3 The MPR shall be divided into four (4) sections,
 - i. The first covering financial status, and current status relating to design, RAMS;
 - ii. The second covering manufacturing, procurement and material testing and deliveries;
 - iii. The third covers the physical progress, interface issues, programme update (including the 3-month rolling programme) showing the current status of construction and installation progress, and
 - iv. The fourth section covers safety, production, testing, commissioning, environmental and training etc.
- 8.4 A Monthly Progress Meeting (MPM) to monitor the progress of the project shall be convened by the Engineer and attended by the Contractor’s Representative, the Employer and

representatives of all interfacing parties shall be invited and may also be present in the meeting.

9 QUALITY ASSURANCE

- 9.1 The Contractor shall establish and maintain a Quality Assurance System in accordance with **Appendix 6** for the design and construction procedures and the interfaces between them.
- 9.2 This Quality Assurance system shall be applied without prejudice to, or without in any way limiting, any Quality Assurance Systems that the Contractor already maintains.
- 9.3 The Quality Assurance Plan shall, without limitation, include for quality assurance procedures for Design, Construction, Manufacturing, Procurement, Supply, Installation, Testing and Commissioning and shall control processes for each stage in the Works such as for design verification and validation, management of change control, non-conformance procedures, inspection, testing, auditing and the like.

10 SOFTWARE SUPPORT

- 10.1 The Contractor shall provide to the Employer and the Engineer with one licensed copy for each party, the software packages and software products as those that the Contractor intends to use for the project, inclusive but not limited to programs for business administration, project management, design development etc.
- 10.2 The Contractor shall provide full support to the Employer or to the Engineer for all computer programs to be provided by the Contractor under item (1) above.
- 10.3 The Contractor shall submit a software support plan at least ninety (90) days before start of software installation.
- 10.4 This plan shall require the Contractor to provide all changes, error fixes, updates, modifications, amendments and new versions of the program as required by the Engineer.
- 10.5 The Contractor shall provide all tools, equipment, manuals and training necessary for the Employer / Engineer to maintain and re-configure all the software provided under the Contract.
- 10.6 The Contractor shall submit all new versions of the software to the Engineer for review at least 2 weeks prior to their installation.
- 10.7 New versions of any program shall not result in any non-conformance with the Specification or degrade the operation of the System.
- 10.8 The Contractor shall deliver to the Employer any latest version, together with the updated instructions, and Operation and Maintenance Manuals.
- 10.9 The Engineer shall not be obliged to use any latest version of the software and this requirement shall not relieve the Contractor of any of its obligations.

10.10 TRAINING & TRAINING SCHEDULE

- 10.10.1 The Contractor shall provide training for the Engineer's and Employer's staff to enable the Engineer and Employer to make proper use of any track components, equipment, operation and maintenance instructions, and software installed and its new versions.
- 10.10.2 Training shall commence within one (1) month of the beginning of design.
- 10.10.3 Refer to Part 5 for further details on Training.

11 CONTRACTOR'S LABOUR

- 11.1 The Contractor shall comply will all applicable labour laws and regulations of the Republic of Azerbaijan for the recruitment of all its labour, in particular the Migration and Labour Codes of the Republic of Azerbaijan.
- 11.2 The Contractor shall ensure that the core labour standards and the applicable law and regulations of the Employer's Country are complied with during Project implementation.
- 11.3 The Contractor shall use its best efforts to maximise employment of women and local people, including disadvantaged and affected persons living in the Project area.
- 11.4 The Contractor shall document and communicate to all workers their working conditions and terms of employment, including their entitlement to wages, hours of work, overtime arrangements and overtime compensation, and any benefits (such as leave for illness, maternity / paternity or holiday).

12 CO-ORDINATION WITH INTERFACING AND OTHER PARTIES

12.1 General

- 12.1.1 The Contractor is responsible for detailed co-ordination of his design, manufacturing, procurement, installation, construction, testing and commissioning activities and will take the lead in the management of the co-ordination process with ADY and railway operators, interfacing contractors, utility agencies, statutory authorities, private service providers, consultants, and other contractors whether or not specifically mentioned in the contract that may be working on or adjacent to the site for the purpose of the project, or stakeholders of other adjacent or interfacing projects.
- 12.1.2 For the purpose of these requirements, all of the above parties, shall be referred to as interfacing parties and a number of the main interfacing parties and main interface responsibilities are listed Appendix 3.
- 12.1.3 The Contractor is obliged to arrange the interfacing issues with the interfacing parties for the purpose of the project with reference to these Technical Requirements and Sub-Clause 4.6 – Co-operation, of the General Conditions of Contract.
- 12.1.4 The Contractor shall note that there are other contractors, consultants, etc. which the Employer may engage from time to time and with whom the Contractor shall have to similarly co-ordinate.
- 12.1.5 The co-ordination responsibilities of the Contractor shall include but 'not be limited to the following:
- a) Provision of all information reasonably required by the interfacing parties in a timely and professional manner to allow them to proceed with their design or construction activities, for sharing possessions and specifically to meet their contractual obligations.
 - b) Assurance that the interfacing parties' requirements are provided to all other interfacing parties before the cut-off dates as identified in the Interface Management Plan (IMP) as defined in **Appendix 3**.
 - c) Receipt from the interfacing parties of such information as is reasonably required to enable the Contractor to meet the design submission dates as identified in **Appendix 3**.
 - d) Where the execution of the work of the interfacing parties depends upon the site management or information to be given by the Contractor, the Contractor shall provide to such interfacing parties the services or information required to enable them to meet their own programme or construct their work.
 - e) Co-ordination and sharing of Track Possessions, access and delivery routes, and assurance that all provisions for access and delivery of plant are co-ordinated with and reflected in the interfacing parties' delivery route drawings.
 - f) Co-ordination with the interfacing parties on attendance.
 - g) Attendance and participation at regular co-ordination meetings convened by the Engineer with the interfacing parties.
 - h) The Contractor shall conduct separate meetings with the interfacing parties as necessary to clarify aspects of the interfacing requirements of the Works.
 - i) The party convening the meeting shall prepare minutes recording all matters discussed and agreed at the meeting, and maintain a copy of the minutes for record and audit purposes.
 - j) Assurance that copies of all correspondence, drawings, design reports, meeting minutes, programmes, etc. relating to the Contractor's co-ordination with the interfacing parties are issued to all concerned parties and four (4) hard copies and one (1) soft copy issued to the Engineer no later than three (3) calendar days from the date of such

correspondence and meetings, and shall include a soft copy of all relevant drawings and design reports.

- 12.1.6 The Contractor shall, in carrying out his co-ordination responsibilities, provide sufficient information for the Engineer to decide on any disagreement between the Contractor and the interfacing parties as to the extent of services or information required to pass between them. If such disagreement cannot be resolved by the Contractor despite having taken all reasonable efforts, then the decision of the Engineer shall be final and binding on the Contractor.
- 12.1.7 Where an Interfacing Contract has yet to be awarded, the Contractor shall proceed with the Co-ordination activities with the Engineer until the Interfacing Contractor is appointed.
- 12.1.8 The Contractor shall provide the Interfacing Contractor with all information necessary to enable the Interfacing Contractor to follow-on and proceed with their co-ordination,
- 12.1.9 The Contractor shall note that the information exchange is an iterative process requiring the exchange and updating of information at the earliest opportunity and shall be carried out on a regular and progressive basis so that the process is completed for each design stage by the respective dates.
- 12.1.10 The Contractor shall co-ordinate with the Engineer on all matters relating to works that may affect the ADY operation of the existing route, such works shall be carried out in accordance with applicable norms and standards, foreseen in the "Urban Planning and Construction Code" of Azerbaijan Republic, relevant construction and design normative documents, as well as ADY Rules and Regulations.

12.2 Dedicated Co-Ordination Team

- 12.2.1 The Contractor shall establish a dedicated co-ordination team, led by a Chief Co-ordination Manager on the Site reporting to the Contractor's Representative.
- 12.2.2 The primary function of the team is to provide a vital link between the Contractor's design and construction teams and the Interfacing Parties.
- 12.2.3 The Chief Co-ordinator shall assess the progress of the co-ordination with the interfacing Parties by establishing lines of communications, and indicate these in a co-ordination model shown in the Contractor's Organisation Chart, to promote regular exchange and updating of information to maintain the Contractor's programme.
- 12.2.4 The complexity of the Project and the importance of ensuring that works are executed before the key dates requires detailed programming and monitoring of progress so that early programme adjustments can be made to minimise the effects of potential delays.
- 12.2.5 The Chief Co-ordinator in conjunction with the interfacing parties shall identify necessary provisions in the works for plant, equipment and facilities of the interfacing parties and these provisions shall be provided by the Contractor in his design of the Works.
- 12.2.6 During the contract period, information will be obtained in a number of ways, and these may include direct "on-site" inspections, regular site meetings, the obtaining of progress reports and the use of reporting documents to obtain design and programme data.
- 12.2.7 Reporting documents shall be issued by the Contractor to the interfacing parties to be returned giving the status of their activities and data required for the works.

12.3 Design Interface

- 12.3.1 The dates shown in **Appendix 2** are critical to the timely completion of the project and the dates have been determined to create a time frame during which design interaction with the interfacing parties on the Project should be completed in order for the construction interface to follow.
- 12.3.2 The Contractor shall commence the design interface with the Interfacing Contractor as soon as he has been notified by the Engineer that an Interfacing Contract has been awarded.
- 12.3.3 In the case of utility agencies and other statutory boards, interfacing shall commence as soon as it is practicable
- 12.3.4 The Contractor shall, immediately upon award of the Contract, gather all necessary information and develop his design to a Concept Design level where meaningful interaction can take place.
- 12.3.5 The Contractor shall submit together with each of his Design Submissions a joint statement from the Contractor and the relevant Interfacing Party confirming that design co-ordination is underway (for Concept and Preliminary Design stages), and has been completed (at the Reference Design stage) and that they have jointly reviewed the appropriate document to ensure that a consistent design is being presented. (Refer to Engineering Design Assurance Gate Procedure).
- 12.3.6 The design interface is an iterative process requiring regular exchange and update of interfacing information and the Contractor shall ensure that the information it requires from the interfacing parties is set out in an Interface Register at the outset of each design interface so that the information can be provided in time for the Contractor and the interfacing parties to complete their design to meet their various design submission stages.

12.4 Construction Interface

- 12.4.1 Construction interfacing will be necessary throughout the duration of the Works commencing from the time the Contractor mobilises on the site to the completion of the Works. Construction interfacing will overlap the design interface and involve the definition of interfacing parties' requirements for provision of cast-in and buried items in the Contractor's works interfacing parties 'that are to be incorporated at the initial stages of the Contractor's installation up to provision of attendance during the testing and commissioning stage.
- 12.4.2 The Contractor shall ensure that there is no interference with the Works of the interfacing parties and shall maintain close co-ordination with them to ensure that his work progresses in a smooth and orderly manner.
- 12.4.3 The Contractor shall carry out and complete the Works, or any part thereof, in such order as may be agreed by the Engineer or in such revised order as may be instructed by the Engineer from time to time.
- 12.4.4 The Contractor shall prepare a Co-ordinated Installation Programme (CIP) for each section of the Work on a works element basis covering the period of Interfacing Contract access.
- 12.4.5 The CIP shall allow adequate time periods for each Interfacing Party and the Contractor to install their plant and equipment in the station areas, and other areas as required.
- 12.4.6 The CIP shall be agreed with and signed off by each Interfacing Party and then submitted to the Engineer initially no later than six (6) months before the earliest works area access date defined in **Appendix 2**, and thereafter updated and submitted on a rolling monthly basis.

12.5 Temporary Use of Track Before Completion & Access Schedule

- 12.5.1 The Employer, railway operators, and other Contractors involved in the Project shall have the right to temporarily use any section of the Works before completion thereof, if required. The Contractor agrees that the Employer, railway operators, other Contractors, and the railway integration, electrification and signalling system Contractors, will require temporary access to sections of the Works or the Site before the issue of the Taking-Over Certificate to perform other works and services. The Contractor shall allow such access to take place in those track sections in which works are in progress and in which safe train or vehicle operation, prior to testing and commissioning, can be conditionally granted at no additional cost. Such partial use or access shall be a temporary measure, in accordance with Sub-Clause 10.2 of the GCC, and shall not be construed as formal acceptance of the Works in whole or part thereof.
- 12.5.2 The Contractor shall cooperate with the Employer, railway operators, railway integration, the electrification, and signalling system Contractors and other Contractors to develop a temporary access regime which shall describe the extent and location of and any other relevant matters relating to such temporary access (including possession times, works progress, load and speed restrictions, health & safety, security, insurance and the co-ordination of activities on site) before the other works and services commence. Such access schedule, once agreed between the parties (including any revised version thereof), is referred to in this Contract as the "Access Schedule".
- 12.5.3 The Contractor shall prepare and agree with the Employer, railway operators, railway integration, the electrification and signalling system Contractors and other Contractors (as the case may be) a schedule of conditions for the areas to which temporary access will be given, based on a joint inspection to assess these conditions and the safety of the related track section prior to any partial use of, or access to, the Site by others.

12.6 Employer's Input Interface, & Other Activities

- 12.6.1 The Employer will provide some Co-ordination for the Contractor with reference to interfacing with third parties during all the phases of the Contract, however the Contractor shall take the lead role and make first contact with interfacing parties.
- 12.6.2 The Employer, within the scope of the relevant Contract provisions, will support and assist the Contractor for interfacing State and local authorities for timely receipt of the required permits, certificates and approvals related to the design and construction process;
- 12.6.3 Any other fields of activities related to the Contract as may be required with the purpose of facilitating the Contractor's performance.
- 12.6.4 This support and assistance of the Employer shall not release the Contractor of any of his obligations under this Contract.

12.7 Support by ADY Maintenance Personnel

- 12.7.1 The existing signalling and Overhead Catenary System (OCS) is not anticipated to be altered for the Track Works contract, except on the main line where realignments are required and the OCS needs to be adjusted. Along the line the signalling system has existing various bonded cable attachments to the rail at each signal and other locations and these will need to be detached and reattached, and replaced as necessary. There are existing attachments made to the rail and also where turnouts are to be removed and replaced from the mainline, and also at locations where the main line shall be "straight railed" and these will require detachment, reattachment and re-routing. Additionally in some of the yards where these may be signalled and electrified, some dismantling and detachment/reattachment will be required.
- 12.7.2 Any materials for attachment, detachment or cable to be renewed due to any reason, or extended, shall be to the Contractor's account, the cost for which shall be included as part of the overall track works.

- 12.7.3 The Contractor's responsibility for this aspect of the Works is to consult and co-ordinate with the ADY signalling and OCS maintenance personnel to attend and have this work undertaken by these personnel (or Others as they may choose) in a timely manner.
- 12.7.4 If any signalling equipment or OCS equipment is required to be removed and later re-installed, such work shall be undertaken by the Contractor under the direction and supervision of the ADY maintenance personnel. The Contractor shall ensure ADY personnel are in attendance for this work.
- 12.7.5 Like all interfaces with other Contractors, the interface with the ADY maintenance personnel shall be regarded in the same way. A CIP for the input of ADY maintenance personnel shall be developed co-jointly with the ADY Maintenance personnel and submitted to the Engineer for approval at least six (6) months prior to this work being required to commence. The Contractor's Co-ordination team shall be responsible for coordinating the ADY maintenance personnel and ensure all necessary permits and notices are obtained and issued in accordance with ADY work procedures and approval processes, and ADY railway safety work procedures. The Contractor shall arrange to provide transport for the ADY personnel to provide the necessary attendance for the periods agreed. This support is a "free service" provided to the Contractor by ADY.

12.8 Local Taxes, VAT & Import Duties etc.

- 12.8.1 Interfacing State and local tax authorities for all tax issues and import duties arrangements is solely the responsibility of the Contractor.

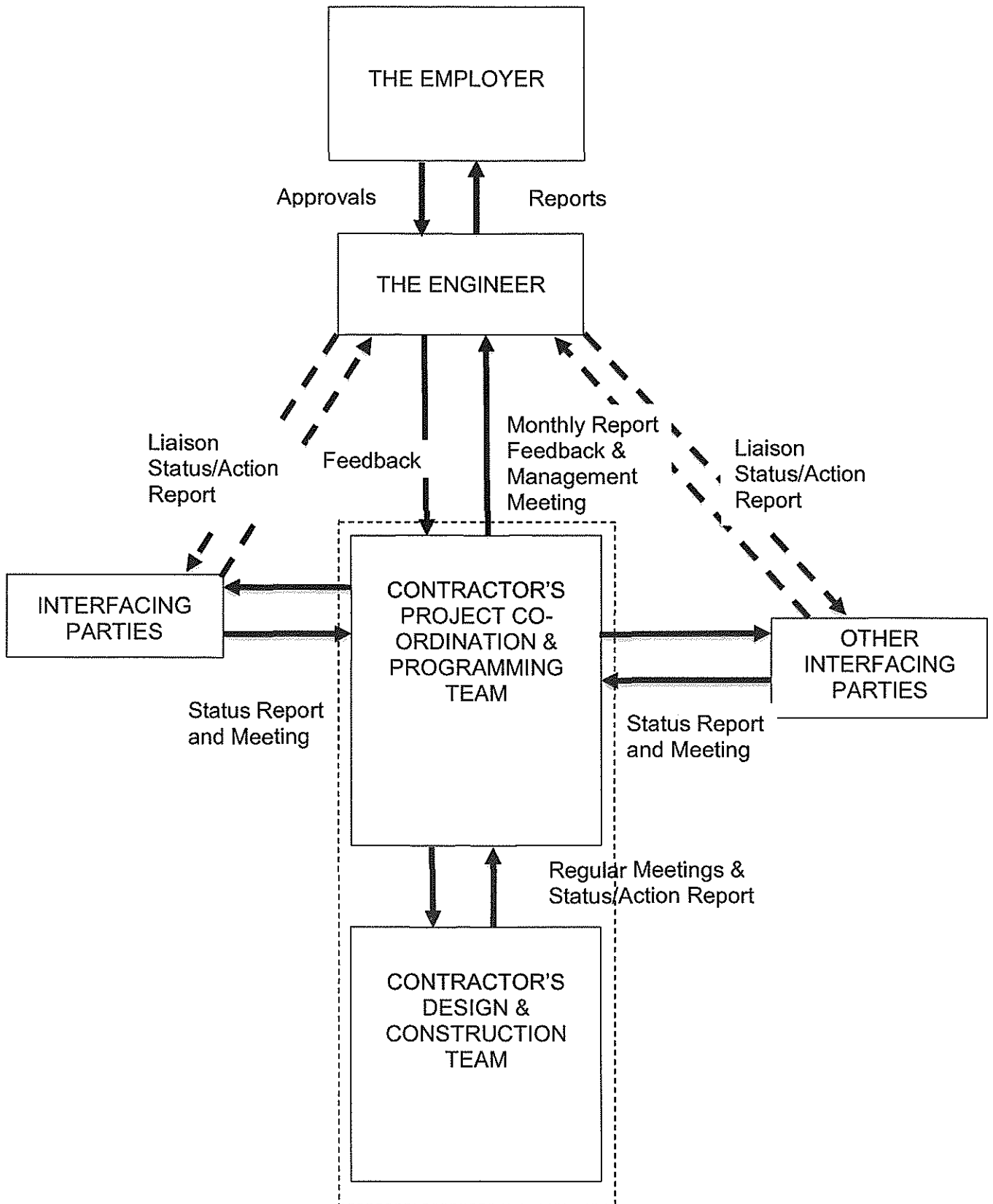

13 ELECTROMAGNETIC COMPATIBILITY

- 13.1 The Contractor shall be responsible for the detailed co-ordination of his design and construction activities and shall take the lead in the management of Electromagnetic Compatibility (EMC).
- 13.2 The Contractor shall be responsible for protection of the works of the interfacing parties from electromagnetic interference arising from his design in conjunction with the characteristics of the traction and rolling stock to be operated over the route while the Contractor's EMC responsibilities shall include but not be limited to the following:
- (a) Provision of all information reasonably required by the interfacing parties in a timely and professional manner to allow them to proceed with their EMC design or construction activities.
 - (b) Assurance that the interfacing parties "EMC" requirements are provided to all other interfacing parties before the cut-off dates as identified in the IMP as defined in **Appendix 2.**
- 13.3 The Contractor shall, in carrying out his EMC co-ordination responsibilities, provide sufficient information for the Engineer to decide on any disagreement between the Contractor and the interfacing parties as to the extent of services or information required to pass between them.
- 13.4 If such disagreement cannot be resolved by the Contractor, then the Engineer shall proceed in accordance with the provisions of the Contract Conditions.
- 13.5 Where an Interfacing Contract has yet to be awarded, the Contractor shall proceed with the co-ordination activities with the Engineer until the Interfacing Contractor is appointed.
- 13.6 The Contractor shall provide the Interfacing Party with all information necessary to enable the Interfacing Contractor to follow-on and proceed with their co-ordination.
- 13.7 The Contractor shall co-ordinate with the Engineer on all matters concerning EMC relating to works that may affect the ADY operation of the existing route and pay special attention to the EMC protection of international, national, regional, private and ADY telecommunication, radio and TV nets where such work shall be carried out in accordance with ADY Rules and Regulations.

14 RELIABILITY, AVAILABILITY, MAINTAINABILITY & SAFETY (RAMS)

- 14.1 The safety of operators, passengers, staff and the general public is of paramount importance for the operation of all ADY railway lines. As part of the Contractor's consideration of safety, as well as reliability, availability and maintainability in relation to the design and construction of the Works, the Contractor shall follow the system assurance requirements and targets stipulated in these Employer's Requirements.
- 14.2 The Contractor shall submit system assurance documents i.e. his RAMS Plan, to the Engineer within one (1) month of the Date of Commencement.
- 14.3 The RAMS Plan shall identify and list all applicable Azerbaijan national standards, statutory and regulatory requirements; railway related standards; international standards and Codes of Practice relevant to the design of the Works undertaken.
- 14.4 The system assurance activities and process shall comply with EN 50126, EN 50128, EN 50129, and IEC 61508 as appropriate, or equivalent standards as approved by the Engineer.
- 14.5 The RAMS Plan shall clearly demonstrate that all issues related to RAMS will be managed during all phases of the project. The RAMS Plan shall identify the management process which

will address all aspects of the Works as a System and must be demonstrably integrated into the Project. This is to be achieved through the development of a process that as a minimum shall address the following:

- (a) Definition of RAMS requirements.
- (b) Planning and implementation of RAMS tasks for all project phases.
- (c) Assessment and control of impacts and threats to RAMS requirements.
- (d) Demonstration of compliance with RAMS requirements.
- (e) Program of ongoing monitoring of compliance.

- 14.6 The Contractor shall comply with the requirements of Appendix 14, which defines the scope of the processes related to RAMS management for the project.
- 14.7 The RAMS plan shall provide for the compatibility between all railways in Azerbaijan as well as the neighbouring country' railways.
- 14.8 The Contractor shall provide a RAMS Analysis Report which shall contain a full description of each sub-system major equipment critical to the reliability of the system. The Contractor shall apportion the reliability target for each sub-system / major equipment and produce an overall reliability analysis and prediction for the Works, to demonstrate the reliability target is achievable.
- 14.9 The Contractor shall prepare the reliability prediction and present it as part of the RAM Analysis Report and submit to the Engineer for approval as part of the design stages.
- 14.10 The overall RAM target and availability target for the Track Work is set out in **Appendix 14 – Reliability, Availability, Maintainability, & Safety (RAMS)**.

15 SURVEY AND CONTROL POINTS

- 15.1 The project data used for the Contract shall be the Azerbaijan Standard Data.
- 15.2 The Contractor shall survey the whole Site to determine the ADY boundaries, and establish on ADY RoW, permanent survey markers (control point monuments) of similar design as the national survey markers from the registered/official national survey markers and benchmarks located out of the Site. From these newly established survey markers the Works shall be accurately set out, and shall have defined geodetic information such as GPS coordinates, latitude & longitude, and absolute elevation in Baltic Elevation System (BES). Accuracy of the newly established survey markers shall be in conformance with the requirements of MENR and any other relevant government agency of Republic of Azerbaijan.
- 15.3 Permanent markers (control point monuments) within ADY right-of-way, will be used for setting out the track alignment. These control point monuments shall be located at intervals not exceeding two (2) kilometres.
- 15.4 Details of each permanent marker including geodetic information shall be submitted as As-Built Drawings to the Engineer.

16 PROJECT MANAGEMENT INFORMATION SYSTEM (PMIS)

- 16.1 The Contractor shall procure and utilise a PMIS such that all documents generated by the Contractor can be transmitted to the Engineer by electronic means, as well as hard copy.
- 16.2 The PMIS shall also allow all documents generated by either party to be electronically captured at the point of origin, stored by either party, and be reproduced later both electronically and in hard copy.
- 16.3 The PMIS Software shall support all Project management knowledge areas for the Project including:
 - a) All Project Communications,
 - b) Project Reporting,
 - c) Integration Management,

- d) Scope Management,
 - e) Time Management,
 - f) Cost Management,
 - g) Quality Management,
 - h) Project Procurement Management, and
 - i) Stakeholder Management, and
 - j) Human Resource Management.
- 16.4 The PMIS Software shall be a cloud-based multi-user application.
- 16.5 All communications transmitted under the PMIS shall be considered a valid form of communication under the Contract, however the following shall also require a hard copy original to be lodged by hand with the Engineer (with receipt issued) to be considered valid. These are GCC notifications submitted in accordance with:
- i. Sub-Clause 1.1.6.10 & 20.4 [Notice of Dissatisfaction];
 - ii. Sub-Clause 2.5 [Employer's Claims];
 - iii. Sub-Clause 14.3 [Application for Interim Payment Certificates];
 - iv. Sub-Clause 14.6 [Issue of Interim Payment Certificates];
 - v. Sub-Clause 15.1 [Notice to Correct];
 - vi. Sub-Clause 19.2 [Notice of Force Majeure];
 - vii. Sub-Clause 20.1 [Contractor's Claims]; and
 - viii. any other documents reasonably required by the Employer / Engineer such as duplicate copies of all official communications, including reports, drawings etc. where the hard copies shall constitute the official record.”.
- 16.6 PMIS training (and ongoing Help Desk support) for 42 months for all Employer/Engineer personnel connected with the Project shall be undertaken by the supplier of the PMIS, at no additional cost to the Employer.
- 16.7 One copy (including Licence for at least 42 months) of the PMIS software shall be supplied and installed in the Employer's office in Baku and one copy in the Engineer's office at Site.
- 16.8 Upon Contract Completion the PMIS system, 12 month Licence, SQL Server with all software and (2) desktop PC's set up to operate the PMIS, shall be handed over to the Employer for their continued use.

17 ASSET MANAGEMENT SYSTEM

- 17.1 The Contractor shall procure, establish and upload with the required data, an Asset Management System (AMS) that is compliant with ISO 55001:2014, particularly for the railway infrastructure assets on Lot 1.
- 17.2 The AMS shall use a systematic process for managing the development, operation, maintenance, upgrading, and disposal of assets cost-effectively, and shall be expandable to take other similar assets from the Employer's other areas of the rail network.
- 17.3 The AMS shall be a cloud-based multi-user application.
- 17.4 Training and support for the Employer/Engineer personnel in its use and operation shall be undertaken so they are fully competent and conversant in the operation, use, expansion and maintenance of the AMS.
- 17.5 Details of the AMS and its operation shall be developed by the Contractor during the Design Stage and shall be implemented after Definitive Design Approval.
- 17.6 Upon Contract Completion the AMS, 12 month Licence, SQL Server with all software and (2) desktop PC's set up to operate the PMIS, shall be handed over to the Employer for their continued use.

18 TECHNOLOGY TRANSFER & TRAINING

- 18.1 The Contractor shall ensure that all local contractors and sub-contractors engaged in the works are given training, guidance and the necessary opportunity for transfer of technology.
- 18.2 The training shall be provided in various areas of construction such as bridge & culvert construction, bridge and culvert maintenance, instrumentation, safety, quality assurance, track laying, installation of CWR, including Turnouts incorporated in CWR.
- 18.3 A Training Schedule shall be developed by the Contractor and agreed with the Engineer and ADY for all training to be undertaken (including software training – see Section 10.3). The Training Schedule shall include details of the training to be undertaken, the duration of each training session, the name of the trainer, and the venue for training. Some training can be undertaken out of Azerbaijan if the Contractor considers this is warranted, and the Contractor covers all related travel, accommodation and subsistence costs of trainees.
- 18.4 The Training Schedule shall be updated on a monthly basis and submitted with the MPR for reference purposes.
- 18.5 The cost of all aspects of the training including but not limited to the planning, training materials, transportation, accommodation, meals and living costs, trainer's costs, venue costs etc., shall be borne by the Contractor and included in the cost for the Works.

19 TRANSLATIONS OF CONTRACTOR'S DOCUMENTS

- 19.1 All documents, reports, correspondence and the like shall be submitted by the Contractor in both English and the Azeri languages.
- 19.2 The English language shall prevail as the language of communication of the Contract.
- 19.3 All drawings shall be in English with Azeri text on the drawings in parentheses.

20 MAINTENANCE OPTION

- 20.1 During the course of the Contract execution, the Employer may request the Contractor to enter into a Maintenance Contract with the Employer for the Railway Track provided under the Contract under terms and conditions to be mutually agreed.
- 20.2 The Maintenance period is anticipated to be for five (5) years with an option for a further five (5) years subject to mutual agreement.
- 20.3 This is only a potential option and the Employer is not bound to proceed with the maintenance of the railway track by the Contractor.
- 20.4 No pricing for the Maintenance Option is required at tender.

PART 2

TECHNICAL SPECIFICATION – FUNCTIONAL

1 OBJECTIVE

- 1.1 The Contractor shall undertake the design, construction, manufacture, procurement, supply, installation, testing and commissioning of the civil, structures, builders work, track, and all other required items, and without limitation, the design, construction and removal of the Temporary Works.
- 1.2 In addition, the Contractor shall undertake the rectification of defects appearing in the Permanent Works in the manner and to the standards required for new works and within the time stipulated by the Contract. In full recognition of these objectives and with full acceptance of the obligations, the Contractor shall execute the Works considering all liabilities and risks that may be involved.

2 GENERAL DESCRIPTION

- 2.1 The design and performance of the Permanent Works shall comply with the specific requirements contained in these documents, and the details set out in **Appendix 1**.
- 2.2 The design of the Permanent Works shall be developed in accordance with these Technical Specification, the Contractor's Proposals and the other requirements of the Contract.
- 2.3 The Contractor shall prepare and submit to the Engineer, the Design Reports developed from these Technical Specifications, the Definitive Design – split in different design stages as described in these Employer's Requirements - for the Permanent Works which shall comply fully with these Employer's Requirements, and the Standards and Design Codes which are in accordance with or defined and listed in the Design Criteria and Codes for Civil and Track Works (**Appendix 16**).
- 2.4 In addition, the Definitive Design shall comply with applicable norms and standards, foreseen in the "Urban Planning and Construction Code of the Republic of Azerbaijan", relevant construction and design normative documents, as well as ADY Rules and Regulations (AzDNs/GOST, SNIP) and regulations for works carried out within the Railway right-of-way.

3 SCOPE OF WORKS FOR LOT 1:

- 3.1 All the Works shall be based on approved Concept Designs developed by the Contractor to be based on the Employer's Requirements, then developed by the Contractor as the Preliminary Design and developed further into the Contractor's Definitive Design and Reference Drawings. The table below outlines in summary the scope of work required to be undertaken. (Note: Not all activities are set out in the table below.)

SCOPE OF WORK – SUMMARY OUTLINE	
Work Type	Description
Track Alignment	Survey and Design the track alignment with the existing alignment as a base. Design and construct improved track alignment at locations where the alignment is skewed to avoid bridge & culvert structures, platforms etc. to make the mainline as straight as practicable. Embankment widening may be required dependent on design.
Track Sub-structure	Excavation to a depth of 1050mm below the top of rail. Test, compact and shape sub-grade. Supply and install 300mm sub-ballast, compact and test. Excavate a further 200mm in selected areas and supply and install geo-grid, and geotextile where required, and re-fill with compacted sub-ballast material. Supply and install 350mm ballast below sleeper, compact, and test.
Renewal of Track	Dismantling, cleaning, cartage and storage of old track components. Complete dismantling, cleaning and return to ADY store of all un-required track and turnouts for Track 3 & Track 4 and yard tracks at Yasma and Gil-Gil Cay. Supply and install new R-65 rail, new pre-stressed monoblock concrete sleepers with new elastic rail fasteners. Weld rail into CWR.

SCOPE OF WORK – SUMMARY OUTLINE	
Work Type	Description
	Supply and install GIRJ's and Mechanical IRJ's. Supply and install top ballast and shoulder ballast, Tamp track to required level and alignment using heavy on-track tamping machine.
	Supply, install and continuously weld new turnouts on pre-stressed concrete bearers on mainline (1:11 and 1:9), and supply and install refurbished turnouts for Tracks 3 & 4 at stations, including tamping, levelling and aligning turnouts using heavy on-track turnout tamping machine.
Contaminated Areas for Excavation & Reconstruction	Dismantle track, remove contaminant with contaminated ballast & sub-ballast to a depth of 1050mm from ToR & 2.7m wide, clean all track components, and dispose of all contaminated material in the designated and approved locations.
Drainage Improvement	Track drainage design, supply and installation of necessary drainage to ensure the track drains satisfactorily. Drain types include V-drains, U-drains, lined and unlined ditches, French drains etc. as required by designer. Embankment widening may be required dependent on design.
Hydrological Study	Hydrological Study to determine waterway openings and drainage requirements along all of Lot 1. To be used in the design for sizing existing structures requiring renewal, other structures as required and determining and designing surface drainage requirements.
Geotechnical Assessment	Geotechnical assessment for all pedestrian overpasses, bridges, culverts and pipe crossings, and other locations as required.
Level Crossings	Complete removal of all level crossings and reconstruction of a 10 level crossings with rubber/polymer or concrete panels and improvement of road approaches.
Animal Crossings	Design and construction of suitable animal crossings at 9 locations along the Line.
Pedestrian Overpass	Design and construction of 7 pedestrian overpasses on the Line
Rehabilitation and reconstruction of Bridges & Structures (includes Culverts)	Design and construction/rehabilitation of bridges and structures on the Line, including replacement. This work includes all aspects of work required to raise the bridges and structures to the life expectancy specified. All bridges and culverts shall be ballast top.
Rehabilitation and reconstruction of Culverts & Pipe Crossings	Design and construction/rehabilitation of culverts on the Line. This shall include conversion of some bridges/structures or pipe crossings to culverts. This work includes all aspects of work required to raise the culverts & pipe crossings to the life expectancy specified.
Cable Ducts	Signalling ducts (including access pits and cable pulling pits) are required to be installed to the design specified by the interfacing signalling contractor.
Fencing	Survey on ADY right-of-way. Design and construction of two types of fencing with pedestrian and vehicle gates along the ADY right-of-way.
Signage	Project signage; track signage; fouling markers; kilometre and 100m posts, speed signs etc.
Interface Management	Interface with direct interfacing contracts for Power Supply and Overhead Catenary, and Signalling Renewal, including design co-ordination, construction co-ordination and attendance.
Existing Signalling & Overhead Catenary Systems (OCS)	The Existing Signalling & Overhead Catenary Systems (OCS) are required to be kept operational at all necessary times and on Completion of the Works.

- 3.2 This Contract is Lot 1 from Sumgayit Station to Gil-Gil-Chay Station as defined in Part 1.
- 3.3 The Works are broken down into Sections as defined in the Conditions of Contract ref. PCC Sub-Clause 1.1.5.6. A Section consists of the main line (and some Sections include stations) between two fixed points. A Section includes the first two crossovers near each

- distant station, the lines between and through the next station but not including the two crossovers beyond the station. Refer to **Appendix 2** for details of Sections.
- 3.4 The Definitive Design and Drawings for each individual Section shall be completed and 'Approved' before any works can be undertaken on that Section.
- 3.5 These sections shall be upgraded to a design speed of maximum 154 km/hr for conventional passenger trains and 90 km/hr for freight trains for the mainline tracks, i.e. Track N°1 and Track N°2.
- 3.6 The Contractor shall carry out the track Installation with Special Equipment and Material, as indicated on the Appendix 22, in accordance with standard requirement for Railway Track installation.
- 3.7 Stations:
- 3.7.1 The main line track structure (including ballast, sub-ballast, and drainage) in stations being tracks N°1 & N°2 shall be rehabilitated with new materials including new Turnouts, and the track Siding N°3 and 4 shall be rehabilitated with refurbished second-hand track material plus ~33% of new concrete sleepers with fastenings and complete new ballast, except the Stations of Gil-Gil Cay, Yasma, where only the Main tracks are to be rehabilitated, with some existing turnouts and tracks removed. Refurbished turnouts shall be used on Track 3 & Track 4 for turnouts to adjacent yard sidings.
- 3.7.2 At Yasma and Gi-Gil Cay, Track 3 & Track 4 and all station yard tracks and turnouts at both these locations shall be removed by the Contractor, cleaned and returned to the ADY store. Unusable material shall be agreed with the Engineer and then disposed of by the Contractor. Those materials that the Contractor shall use for refurbished turnouts need not be returned to the ADY store but shall be accounted for when used for the refurbishment works.

4 CONTRACT SCOPE (CIVIL & TRACK WORKS)

- 4.1 The permanent works shall comprise survey, geotechnical assessment, alignment, design, construction, manufacture, procurement, supply, installation, testing and commissioning of:
- a. Survey and Design of track alignment with tangent track, clothoid spiral transition curves and pure circular curves according to ADY track design standards, or appropriate UIC and EN standards.
 - b. Design and installation of track realignment in locations that the Engineer and Contractor agree to be a practical solution to existing deficient alignment issues, and/or for overall improvement of train operations;
 - c. Track sub-structure including but not limited to drainage, embankments, bridges, animal crossings, including pedestrian over passes and reinstatement, except those specifically excluded as set out in **Appendix 20**;
 - d. Track rehabilitation including but not limited to surveys, geotechnical assessments, setting out, benchmarking, curve improvement, replacement of all material in the main line tracks (Switches/turnouts, rail, sleepers, fastenings & fittings, expansion joints (if required), glued insulated rail joints, ballast and sub-ballast), with grading and compaction of the formation to the required specification, etc.;
 - e. Track superstructure construction including but not limited to setting out, benchmarking, frost protection (if required), rail and sleepers with fastenings, switches/turnouts, insulated rail joints, ballast and sub-ballast on Contractor compacted formation, buffer stops if required, expansion joints if necessary, track signage; fouling markers; kilometre and 100m posts, etc.;
 - f. Track superstructure with drainage in all locations including the Stations areas;
 - g. Embankment widening in specific locations where required by the design to permit improved drainage.

- h. Rehabilitation, reconstruction, replacement, and repair of the bridges and culverts according to survey, geotechnical and design requirements. Note that the Employer has undertaken a condition assessment of bridges and culverts and details are available for the Contractor's reference. Many aspects of the work identified in the Employer's condition reports shall be undertaken by the Contractor. The Contractor's own investigations, the Contractor's design and work activities for the remediation and replacement works for bridges and culverts shall additionally be required as shall be the inclusion of the guidelines, references and requirements mentioned in **Appendix 20**;
- i. Concrete, wooden and steel bridge decks replacement with reinforced concrete deck with fully ballasted track. Refer **Appendix 20**;
- j. Reinforcement of the Bridges' foundation (piers, abutments, etc.), as required to suit loading and geotechnical conditions. Refer **Appendix 20**;
- k. Supply and installation of guard rails for bridges that currently have these.
- l. Demolition and reconstruction of all level crossings, and replacement with concrete or rubber/polymer panels structures; design and installation of all drainage, guard-rails, fencing, approach roads (in particular locations), pedestrian paths etc. Refer to **Appendix 11**;
- m. Installation of animal crossings at rail level including all earthworks, embankment widening, gates, cattle grids, etc. at defined locations. Refer **Appendix 11**;
- n. Fencing both sides of the Main Line at various locations of the railway at stations and urban areas. Refer **Appendix 11**;

5 TRACK ALIGNMENT

- 5.1 The alignment for the main lines 1 & 2 and lines 3 & 4 shall be designed by the Contractor and shall meet the ADY operational and technical criteria as well as environment requirements.
- 5.2 The Contractor is permitted to propose minor deviations in alignment to suit his construction proposals and shall eliminate various alignment problems on the existing track. The design shall demonstrate that any such deviations and alignment changes shall comply with good design practice and the alignment requirement of the Design Criteria and shall only be within ADY Right of Way (RoW). Such proposals will be reviewed and accepted at the discretion of the Engineer and Employer.
- 5.3 Where embankments need to be widened to enable track construction, improved alignment, wider ballast shoulders, or for better drainage including additional drains to be installed on the embankments, this work shall also be included.
- 5.4 The Contractor can propose to modify the track parameters (maximum cant/cant deficiency/cant excess, type and length of transitions), in accordance with the relevant standards accepted, taking into account the RAMS requirement. Such proposals shall be reviewed for acceptance as part of the design stages. Proposals for modification must be universal, i.e. for all tracks. Modification proposals will be accepted at the discretion of the Engineer and Employer.
- 5.5 Alignment design shall be in accordance with ADY Standards or relevant international standards such as UIC 703 and EN 13803.
- 5.6 Track tolerances shall be in accordance with ADY Standards or relevant international standards such as EN 13231.

6 CLEARANCES

- 6.1 The Permanent Works shall not infringe on the Structure Gauge as shown on the drawings as listed at **Appendix 1**

- 6.2 The Permanent Works shall provide for the maintenance of the operating railway using on-track tamping and lining equipment, ballast cleaners etc, without infringement of the Structure Gauge.
- 6.3 The clearances both structural and electrical are shown on the railway clearance drawings provided in **Appendix 1**.
- 6.4 Construction Limits are the limits of land for the Permanent Works are defined by the ADY Right of Way (RoW).

7 DESIGN LIFE

7.1 The minimum design life of the Permanent Works shall be:

- a) For new civil and bridge structures: 70years;
For rehabilitated structures: 20 years.
- b) For track structures:
 - Rails: 30 years;
 - Sleepers: 60 years;
 - Fastening System: 25 years
 - Ballast: 15 years.

Note: To achieve the 70years design life for renewed structures and 20 years design life for rehabilitated structures will require the Contractor to undertake investigations for the design of the new and the rehabilitation of the existing structures. The Contractor is required present the investigation detail during all three (3) design stages, for agreement.

7.2 Statement of Maintainability.

The Design Report presented with the Definitive Design for each civil and bridge structure, as well as for all rehabilitated structures shall include a discussion on what maintenance is required and when for each structure so as to achieve or exceed its design life. This discussion is referred to as the Statement of Maintainability.

8 DURABILITY AND MAINTENANCE

- 8.1 The Permanent Works shall be designed and constructed such that, if maintained in accordance with the Contractor's statement of maintainability contained in the Design Reports, they shall endure in a serviceable condition throughout their minimum design lives as described in the Design Criteria and Standards contained in the Technical Specifications.
- 8.2 The Permanent Works shall be designed and constructed to minimise the cost of operation and maintenance whilst not compromising safety or the performance characteristics of the railway.

9 OPERATIONAL REQUIREMENTS

- 9.1 The Permanent Works shall be designed to permit the railway to operate satisfactorily at a design train speed of 140km/hr +14km/hr for line speed =154km/hr for conventional passenger trains and 80 km/hr +10km/hr for line speed = 90km/hr for freight trains.
- 9.2 The Contractor shall ensure and be responsible for the design and construction of the Works that provides a safe construction environment as well as a safe operating environment for passengers, staff and the public as is reasonably and professionally possible,
- 9.3 The design of the works, the construction methods and the works progress shall be such that the commercial train operations, as shown in the historic train operations data presented in **Appendix 17** can be met without risk to the safety of passengers, or railway employees, including during emergency situations, and with minimum disruption to any trains.

- 9.4 Capability shall be provided for reasonably expected operational perturbations (including recovery from these), temporary speed restrictions and abnormal train working.
- 9.5 The requirements for the Reliability/Availability/Maintainability/Safety (RAMS) Plan for the railway system, are stated in **Appendix 14** and are also further defined in the various sections in this document.
- 9.6 It will be necessary for the Contractor to closely interface with the ADY's present Signalling and Electrification System, to ensure that the overall design fully meets the technical and operational requirements.
- 9.7 It is a requirement that the railway remains operational during the construction phase, with the minimum disruption to passengers and freight trains over this period.

10 TIMETABLE FORECAST OPERATIONS (During the works)

- 10.1 Historic details for train operations is attached in **Appendix 17**. The Contractor shall be responsible for obtaining the updated timetables for the actual train movements during the period of the Contract performance from ADY Freight Dept.

11 CLIMATIC CONDITIONS

- 11.1 Information on climatic conditions can be obtained from the Azerbaijan National Institute of Meteorology and Hydrogeology and the Contractor shall verify and, if necessary, update this information when preparing his design.
- 11.2 The following websites may be helpful in assessing climatic conditions:

- <https://www.weatherbase.com/weather/city.php3?c=AZ&countryname=Azerbaijan>
- <http://www.xacmaz.climatemps.com/graph.php>

12 RESPONSIBILITY FOR THE CIVIL WORKS

- 12.1 The Contractor shall be responsible for concept, preliminary and definitive (detailed) design, layout, construction, manufacture, procurement, supply, installation, testing and commissioning, including system sizing of the civil, structural builders' works.
- 12.2 The Civil Works shall conform to:
 - a) ADY Regulations for Technical Railway Operations
 - b) SNIP with GC gauge and ADY Gauge.
 - c) Railway sub-structure and superstructure design and construction to Azerbaijan standards in accordance with the Design Criteria.
 - d) Platform relocation design and construction to SNIP as required as part of the scope.
 - e) Railway bridges, culverts, pipe crossings, and pedestrian overpasses design and construction to European Standards, GOST, SNIP. The type of specified loading equalized with the accepted by ADY loading.
 - f) Environmental mitigation measures for noise transmission in accordance with European Standards.
 - g) Environmental Planning, Monitoring and Assurance in accordance with Azerbaijan Standards.
 - h) Archaeological investigation of several sites along the route in accordance with Archaeology Institute and Museum requirements.
 - i) Noise barriers design, if necessary in accordance with Azerbaijan Standards. If noise barriers are required to be supplied and installed this will be additional to the scope.
 - j) Fencing in accordance with Azerbaijan Standards.
- 12.3 The Contractor shall carry out all necessary works for the replacement, reinforcement and rehabilitation of the existing bridges and structures foundation and superstructure, if necessary after dismantling of the track.

- 12.4 The Contractor shall carry out the design and construction of replacement and refurbished bridges, level crossings, animal crossings, pedestrian overpass, etc., and all other civil works described in the Employer's Requirements.

13 RESPONSIBILITY FOR THE TRACK WORKS

- 13.1 The Contractor shall be responsible for detailed design, layout, construction, manufacture, procurement, supply, installation, testing and commissioning.

- 13.2 The track works shall conform to:

- a) AZDTN/GOST, SNIP, European, UIC and Azerbaijan Standards for design and construction for the main line.
- b) Rail Type R-65
- c) Azerbaijan Standards for the design and construction of the siding and passing tracks
- d) ADY regulations for second-hand R-65 rail
- e) **Appendix 16** – Design Standards and Codes for Civil & Tracks.

14 AESTHETICS

- 14.1 The Permanent Works for the major bridges shall be designed to achieve a high aesthetic character and provide a feeling of design commonality throughout the project.
- 14.2 Allowance shall be made to identify and implement a design that includes but is not limited to the use of common materials, finishes and components and wherever possible reflects the geographic features of the location chosen for the bridge.
- 14.3 The aesthetics view is obligatory for the all parts of the projects. The Contractor shall propose variants for approval by the Employer and Engineer.

15 ENVIRONMENTAL CONSIDERATIONS

- 15.1 The design of the Permanent Works shall be according to Azerbaijan Environmental Laws and Regulations and the Initial Environmental Examination report.
- 15.2 During design and construction, the requirements for Environmental Protection and Impact Mitigation are given in **Appendix 13**.

16 PLANNING SUBMISSIONS

- 16.1 Submissions for planning approval for the project works shall be made by the Contractor to the following authorities. This list is only indicative and not complete. It shall be extended in compliance with the design and construction stages, structures types etc. in accordance with the applicable legislation in force in Azerbaijan.
 - i. Stations Areas including structures and passenger footbridges - local Municipality: Chief Architect of the Settlement, Water Supply and Sewerage Authority, Power Supply Authority, Road Traffic Control Authority and to the Ministry of Environment and Water for the sewerage permit;
 - ii. Reconstruction of Irrigation Systems – Agencies for amelioration and water supply;
 - iii. Reconstruction of Road Connections, road overpasses and underpasses - local Authorities in Settlements and to the Road Executive Agency for other areas;
 - iv. River Corrections - Ministry of Ecology & Natural Resources (MENR);
 - v. Archaeological Sites in proximity to the Alignment- Ministry of Culture;
 - vi. Connections to Industrial Areas – through Employer with the plant owners
- 16.2 The Planning Submissions as indicated above shall be attributed to the Contractor in accordance with the provisions of the Contract.
- 16.3 The Employer will provide some assistance to the Contractor in such activities, as appropriate, however the lead shall be taken by the Contractor.

17 STANDARDS

- 17.1 Track and Civil Works, equipment, materials and systems shall be designed, manufactured and tested in accordance with the latest issue of approved and recognised codes and standards defined proposed for the work.
- 17.2 The Contractor shall submit copies to the Engineer of all relevant parts of the codes and standards used for the work in English and Azeri.
- 17.3 References to standards or to materials and equipment of a particular manufacturer shall be regarded as followed by the words "or equivalent approved".
- 17.4 The Contractor may propose alternative standard materials, or equipment that shall be equal to or better than those specified.
- 17.5 In some defined instances the Contractor may propose alternative equipment which is compatible with specified equipment defined under the Contract.
- 17.6 If the Contractor for any reason proposes alternatives to or deviations from the specified equipment, standards, or desires to use materials or equipment not covered by the specified standards, the Contractor shall obtain the pre-approval of the Engineer and Employer.
- 17.7 The Contractor shall state the exact nature of the change, the reason for making the change and relevant specifications of the materials to prove equipment compatibility in the English and Azeri language.
- 17.8 Refer to **Appendix 16** for further details.

PART 3

TECHNICAL SPECIFICATION - DESIGN OF CIVIL AND TRACK WORKS

1 INTRODUCTION

- 1.1 This Part 3, the Technical Specification - Design of Civil and Track Works, specifies the procedural requirements for the preparation of the design of the Works for structures and track. These requirements are subdivided into those that are to occur during the Design Phase, those that are to occur during the Construction Phase and those that are of typical application.
- 1.2 In addition to the specific requirements stated herein, the Contractor shall, whenever the Engineer or the Employer so reasonably requests, provide information and participate in discussions that relate to design matters.
- 1.3 The Contractor shall engage a Designer who shall undertake and prepare the design of the Permanent Works. The Contractor shall establish an office for his core design team in Azerbaijan from which the core design team shall function and all meetings and discussions relating to design shall be held in that office.
- 1.4 The Contractor shall ensure that the Designer is represented full-time in Baku, Azerbaijan by staff whose seniority and experience are to the satisfaction of the Engineer and whose representative is available on the Site as necessary or as required by the Engineer.
- 1.5 The key Designers who shall formally sign the Design must have the qualifications required by the applicable legislation in Azerbaijan; their Engineering diplomas / certificates shall be legalized by the relevant authorities in Azerbaijan.
- 1.6 The Contractor shall submit his Quality Assurance Plan as required for the design required by the Contract.

2 REQUIREMENTS DURING THE DESIGN PHASE

- 2.1 The principal requirements of the Design Phase are the production by the Contractor of the Contractor's Documents, which shall fully describe the Works and include the Concept Design, Preliminary Design, the Definitive Design and the Reference Drawings. The volume and contents of the documents shall be in accordance with the applicable legislation in Azerbaijan and existing international norms such as European standards, UIC Leaflets and other EC documents, as well as, with the specific Azerbaijan Standard Regulations (GOST, SNIP) where appropriate. See **Appendix 16**.
- 2.2 If there are discrepancies between documents referring to the same subject, the more stringent criteria will be followed.
- 2.3 The Contractor shall obtain all necessary approvals and agreements for his designs at his account in accordance with the applicable legislation in Azerbaijan. This includes responsibility for obtaining the required design approvals from the relevant Government agencies. No claims for delay and/or cost(s) associated with this process will be accepted.
- 2.4 The Concept Design and following design phases, shall incorporate any design included in the bidding and tender documents, and the designs developed by the Bidder/Contractor sufficiently to define the bridges, culverts, drainage and other structures and track alignment. In addition, general construction, manufacture, installation, testing and commissioning methodologies and documentation needed to develop the Definitive Design and Drawings shall be submitted.
- 2.5 The Definitive Design and Drawings shall accord with and incorporate the Contractor's Proposals and shall be the design developed to the stage at which all elements of the structures and track are fully defined and specified. The Definitive Design shall be complete when:
 - (a) all calculations and analyses are complete including verification;
 - (b) all main and all other significant elements are defined;
 - (c) all tests and trials and all selection of materials and equipment are complete;
 - (d) all Design Reports are submitted and accepted;
 - (e) the effects on the Permanent Works of the proposed methods of construction, installation, testing and commissioning and of the Temporary Works are assessed. Refer to **Appendix 24** - Engineering Design Assurance - Gate Procedure for more details.

- 2.6 During the preparation of the Definitive Design, all surveys, investigations and testing necessary to complete the design of the Permanent Works shall be undertaken by the Contractor.
- 2.7 The Contractor shall sub-divide the proposed Definitive Design into Design Packages to be submitted in advance of the Definitive Design Submission and to be identified in the Design Submission Programme. The Design Packages are to relate to significant and clearly identifiable parts of the proposed Definitive Design, as agreed with the Engineer, and shall address the design requirements as described herein. The Design Packages (and included Design Reports) shall facilitate the review and understanding of the Definitive Design and shall be produced and submitted in an orderly, sequential and progressive manner. Four copies of these Design Packages shall be submitted for approval to the State Agency for Control over Construction Safety "GOST expertise" under the Ministry of Emergency Situations of the Republic of Azerbaijan or other institutions nominated by them. After the finalizing of this step the Contractor shall be able to start the next stage of the Project once the Design Gate 3 is satisfactorily passed and notification is received from the Engineer.
- 2.8 Separate Definitive Design Submissions may be prepared for those major elements to be procured by sub-contract, where the sub-contracts include design. Where such work is to be procured by the Contractor based on the Concept Design, design briefs and performance specifications, such documents may be submitted as Preliminary Design then Definitive Design Submissions providing that the design of these elements is finalised, including verification as part of the Reference Drawings which are submitted (see paragraph 2.9 and paragraph 2.11 below).
- 2.9 Upon issue of the Notice of No Objection in respect of the Preliminary Design Submission, the Contractor shall complete the Definitive Design in all respects and produce the Reference Drawings, the purpose of which is to illustrate all the Permanent Works and to be the drawings governing Construction.
- 2.10 Reference Drawings shall fully detail the Construction of the elements covered by the Definitive Design, and shall show, in full, the works to be constructed.
- 2.11 The Definitive Design shall be prepared in accordance with the requirements for technical design in the applicable legislation in Azerbaijan and existing international norms such as European standards, UIC Leaflets and other EC documents, as well as, with the specific Azerbaijan and/or ADY regulations (GOST, SNIP) where appropriate. See Appendix 16.
- 2.12 All technical solutions, schemes, structures, materials should be fully compatible with those used by the Employer and should not conflict with the applicable legislation in Azerbaijan. If there are discrepancies between documents referring to the same subject, the more stringent criteria will be followed.
- 2.13 The Contractor shall prepare the necessary sets of his designs and Design Reports in Azeri for submitting to the relevant authorities responsible for the approvals in accordance with the applicable legislation in Azerbaijan.

3 REQUIREMENTS DURING ANY LAND ACQUISITION PHASE

- 3.1 It is not anticipated that additional land acquisition is required. However, when the Contractor develops his Definitive Design and at that stage identifies the necessity for additional land acquisition and resettlement, the Contractor shall assist and support the Employer to prepare the complete documentation necessary for this additional land acquisition in accordance with the acting Azerbaijan legislation, and ADB requirements, as well as all necessary corrections of the documents during the procedure.
- 3.2 In performing his assist and support obligations as described in 3.1 above the Contractor may at his discretion hire a specialised sub-contractor (an experienced local company) or perform himself all the activities and obligations as described in the whole of this Item 3. The Contractor (or the specialized sub-contractor - if hired) shall support and assist the Employer for preparation of Addendum to the LARP (e.g. design, valuation report, cadastre documents, minutes of the public consultations etc.). Land acquisition, resettlement and compensation payment shall be at the Employer account.

- 3.3 The Contractor (or the specialized sub-contractor - if engaged) shall organize and participate in commissions and public consultations with the relevant authorities concerning the LARP implementation, civil, ecological and archaeological issues and shall comply his designs with their remarks.
- 3.4 LARP needs to be updated by the Employer and approved by ADB and disclosed on ADB website before compensation payment starts. Civil work cannot start at the impact sites until compensation payment is fully completed and result of compensation payment is validated by ADB.

4 REQUIREMENTS DURING CONSTRUCTION PHASE

- 4.1 The principal requirements relating to the Contractor's Documents during the Construction Phase are the production by the Contractor of Working Drawings and Documents, the preparation of technical submissions as required under the Contract, the compilation of the Definitive Design and the production of the As-Built Drawings and Final Documentation,
- 4.2 Working Drawings and Documents shall be prepared as required under the Contract. The Contractor shall endorse the Working Drawings and Documents as being in accordance with the Employer's Requirements.
- 4.3 The Contractor shall endorse the submissions required under the contract that "all effects of the design comprising the submission on the design of adjacent or other parts of the works have been fully considered in the design of these parts".
- 4.4 At least 6 months prior to the anticipated Time of Completion of the Works, the Contractor shall submit any Revised Definitive Design to the Engineer. The Revised Definitive Design can be shown in the As-Built Drawings provided by the Contractor.
- 4.5 The Definitive Design is the design of the Permanent Works embodied in:
 - a) The latest revisions of the documents comprising the Definitive Design, taking account of comments in the schedules appended to Notices of No Objection;
 - b) The latest revisions of the Reference Drawings;
 - c) The calculations; and
 - d) Such other documents as may be submitted by the Contractor at the request of the Engineer to illustrate and describe the Permanent Works and for which a Notice of No Objection has been issued.
- 4.6 The Contractor shall maintain all records necessary for the preparation of the As-Built Drawings and Documents. Upon progressive completion of the Works or at such time as agreed to or required by the Engineer, the Contractor shall prepare drawings which, subject to the Engineer's agreement, shall become the As-Built Drawings and Final Documents. All such drawings and documents shall be endorsed by the Contractor as true records of the construction of the Permanent Works and of all Temporary Works that are to remain on the site.
- 4.7 The Contractor shall maintain all records necessary for the financial completion, testing and commissioning of the Works. These records shall consist of as a minimum:
 - a) The implemented work according to activities, places and price;
 - b) Used materials - type, place, price;
 - c) Any other records as required.

5 DESIGN & CONSTRUCTION INTERFACES WITH INTERFACING PARTIES

5.1 Interface & Co-ordination

The Contractor shall be responsible for all co-ordination of all design and installation work with the various interfacing parties including interfacing contracts, to establish the Co-ordinated Installation Programme (CIP) as defined at **Appendix 3**. The CIP shall be prepared by the Contractor in a format acceptable to the Engineer. The Contractor shall co-ordinate with all interfacing parties to produce a detailed programme of access dates, equipment delivery routes and occupation periods for each area inside the railway envelope.

5.2 Signalling Interface – Cable Ducts

- 5.2.1 The Signalling Contractor is an interfacing party to this contract. If the Signalling Contract is not yet awarded the interface will be with ADY Infrastructure Division through the Engineer.
- 5.2.2 Signalling ducts (including access pits and cable pulling pits) are required to be installed to the design specified by the interfacing signalling contractor. There is an extensive network of ducting to be installed at each station. The ducting required to be installed is shown in **Appendix 1**
- 5.2.3 Ducts shall be installed underground in locations as specified by the Signalling Contractor. There are various termination points in a station area, however the prime location for terminations is in a special designed building/container located in the station area. Terminations will also be in existing station buildings.
- 5.2.4 Particular ducts for power supply and signal detection shall be installed so that the termination point of the duct coincides with the point machine at all turnout locations and the signal locations. (See Diagram Part 3 Clause 7.8.7 v.)
- 5.2.5 Ducts shall also be installed at Level Crossings and at Animal Crossings. At these locations ducts extend for 1,500 m each side of the main lines as well as ducts near the crossing itself and crossing both the main lines.
- 5.2.6 Ducts with termination pits shall also be installed at all Hot Box Detectors.

6 DESIGN SUBMISSIONS

6.1 CONCEPT & PRELIMINARY DESIGN SUBMISSIONS

6.1.1 General

The Concept Design shall provide initial design documents for review and shall be sufficiently detailed to show the element of the design and documents required for preparation of the Preliminary Design. It shall also include, but not be limited to:

- a. The quality assurance plan for design;
- b. A review of the outline design criteria;
- c. The Design Manuals;
- d. Submission of technical specifications proposed for the work;
- e. The identification of design codes and standards;
- f. The concept then preliminary testing and commissioning report i.e. how this work will be undertaken;
- g. The concept then preliminary off-site testing recommendations;
- h. The submission of proposed software;
- i. The CAD procedures;
- j. The concept and preliminary equipment layouts and details;
- k. A survey and alignment review;
- l. Concept then Preliminary details of ballast and sub-ballast sourcing;
- m. Concept then Preliminary details of dumping/borrow areas;
- n. Concept then Preliminary equipment sizing;

- o. Concept then Preliminary equipment proposals;
- p. Concept then Preliminary construction methodology;
- q. Design submission programme (update);
- r. The utility diversion plan;
- s. The Concept then Preliminary track layouts;
- t. Concept then Preliminary signage proposals;
- u. Proposed site surveys and other field surveys;
- v. Concept then Preliminary railway (ballasted deck) bridge proposals;
- w. Concept then Preliminary heavy rehabilitation/repair works for bridge proposals;
- x. Concept then Preliminary light rehabilitation/repair works for bridge proposals;
- y. Concept then Preliminary railway culvert proposals;
- z. Concept then Preliminary heavy rehabilitation/repair works for culvert proposals;
- aa. Concept then Preliminary light rehabilitation/repair works for culvert proposals;
- bb. Concept then Preliminary pedestrian overpass proposals;
- cc. Concept then Preliminary hydrology report;
- dd. Concept then Preliminary seismic report;
- ee. ADY Equipment interface survey;

Refer to **Appendix 24 - Engineering Design Assurance - Gate Procedure**, for more details

6.2 DEFINITIVE DESIGN SUBMISSION

6.2.1 General

The Definitive Design Submission shall be a coherent and complete set of Contractor's Documents, properly consolidated and indexed as a Design Report and shall fully describe the proposed Definitive Design and where appropriate, it shall define but not be limited to:

- a. The dimensions of all major features, elements and members;
- b. Lists and specifications of all materials and components proposed to be used and their source;
- c. Updated detailed Bill of Quantities;
- d. Updated final cost estimate;
- e. Potential forces and movements due to all possible loadings and actions on the bridges and other structures, and their accommodation;
- f. All second order effects;
- g. The layout and typical details of reinforcement in structural concrete members;
- h. The locations and nature of all relevant joints and connections and details thereof;
- i. Final hydrology report;
- j. Final geology report;
- k. Final seismic report;
- l. Final survey report;
- m. Final alignment report;
- n. Standard details;
- o. Temporary works and erection methods;
- p. Utilities to be diverted /supported;
- q. Architectural requirements;
- r. Signage requirements;
- s. Traffic or other civic service affected;
- t. Schedules of all equipment;
- u. Installation methods;
- v. Dumping/borrow areas;
- w. Testing proposals;

- x. Location, geometry and setting out of all main elements and features;
- y. Track condition surveys and rehabilitation details;
- z. ADY equipment interface finalisation;
- aa. Final bridge designs;
- bb. Final culvert designs;
- cc. Final drainage designs;
- dd. Final pipe crossing designs;
- ee. Final civil works design;
- ff. Ballasted Railway deck;
- gg. Rehabilitation of bridges and other structures;
- hh. Lineside Drainage
- ii. Lineside Access Roads
- jj. Lineside Fencing
- kk. Level Crossings
- ll. Animal crossings
- mm. Pedestrian Overpass;
- nn. Elevators for Overpasses
- oo. Provisions and proposals for Construction interfacing with the Interfacing Contractors;
- pp. Report on Interfacing Contracts;
- qq. Testing and Commissioning report;
- rr. Maintenance Report;
- ss. Environmental Impact correction measures;
- tt. Demolition methodologies,

Refer to **Appendix 24** - Engineering Design Assurance - Gate Procedure, for more details

6.2.2 Drawings

The Definitive Design Submission shall include drawings that shall illustrate the proposed Definitive Design and shall include, but not be limited to:

- a) General arrangements;
- b) Location plans, geometry and setting out drawings;
- c) Layouts and details of bridge and culvert structural and track elements;
- d) Layouts and details of Pedestrian Overpasses;
- e) Associated fittings, bridge bearings, handrails, wing walls, aprons etc;
- f) Slopes and earthworks;
- g) Access roads and temporary road works;
- h) Dumping/borrow areas;
- i) Structural and surface drainage;
- j) Existing and proposed utilities;
- k) Road works and works related to traffic management including decking;
- l) Track layouts;
- m) Track details;
- n) Track station layouts;
- o) Track details;
- p) Equipment schedules;

6.3 DOCUMENTS

The Contractor's submissions shall be amplified during the Preliminary and Definitive Design as required and shall include but not be limited to the following documents:

6.3.1 Design Reports

The submissions included in design stage together with the Design Criteria shall be amplified to comprehensively specify the design and construction of the Works, and submitted as Design Reports.

6.3.2 Design Manuals

The Design Manuals shall incorporate all design requirements, standards, codes and all other documents or matters which are relevant to and govern the design in addition they shall refer to all materials, codes and standards used, making clear their specific applications. The Design Manual shall be produced so that it can be used by those involved in the preparation or review of the design of the Permanent Works as a comprehensive reference text and efficient working document

6.3.3 Condition Surveys and Rehabilitation Recommendations

Site and structural investigations, surveys and ground investigations of the existing condition of the track where the structure and sub-structure is to be rehabilitated shall be carried out by the Contractor. Recommendations and designs for rehabilitation works including any ground improvement works, installation of geotextiles, geo-grids, lineside and cross drainage systems and other measures shall be done as part of the Design Phase and implemented during the Construction Phase.

6.3.4 ADY Equipment Interface Survey

Surveys of existing ADY track and equipment at the contract interfaces with the existing railway operations including design details for interfacing new equipment with the existing ADY equipment.

6.3.5 Report on Interfacing Contract

Details of the Design and Construction of the Works sited adjacent to other contracts. Details of provisions required to be provided by the Interfacing Contracts, indicating arrangements for

accesses, fixings, casting in, openings, supports, decks, manholes, trenches and the like, equipment installation in other Interfacing Contractor's works; updated interface management plan relating to design integration and co-ordination.

6.3.6 Test and Commissioning Reports

Details of proposals for testing and commissioning procedures and activities, with required T&C outcomes, for all relevant elements and equipment contained in the Permanent Works.

6.3.7 Maintenance Report

A report updating the Statement of Maintainability in the Contractor's technical proposals and detailing maintenance routines necessary for the achievement of the required lives of the various elements of the Works, especially the structures, level crossings, drainage, turnouts, fastening system, glued insulated rail joints, sleepers, tamping frequency and rail grinding requirements.

6.4 SUPPORTING DOCUMENTS

The Definitive Design Submission shall be accompanied by the following documents, which will be considered by the Engineer in his review of the Definitive Design Submission. Where relevant or required, these documents shall be accompanied by a design note stating clearly how the information has been used in the design of the Permanent Works.

6.4.1 Construction / Manufacturing /Installation Analysis reports

A report containing a stage-by-stage Manufacturing/ Construction/installation sequence for all structures / equipment.

6.4.2 Construction Method Statements

A Construction Methods Report which provides sufficient information on the methods of construction/installation of the Contractor's Equipment shall be provided by the Contractor to allow the Engineer to assess their effects on the Permanent Works and to enable these to be considered in the review of the Definitive Design.

6.4.3 Final Ground & Structures Investigation Report

A report including ground, site and structures investigation results and covering the geotechnical interpretation of site investigation work including that undertaken by the Contractor in sufficient detail to confirm and justify parameters used in the embankment, foundation and geotechnical designs. The report shall include the full logs and descriptions of confirmatory boreholes drilled by the Contractor.

6.4.4 Land Survey Report

A report on all survey work undertaken by the Contractor, including checks on mapping, survey stations, co-ordinates and setting out. Updated topographical and survey drawings shall also be included showing the clear determination of the ADY right-of-way.

6.4.5 Alignment Report

A report on the design and setting out of the track alignment for all tracks, including the realignment of the tracks at specific locations to remove existing alignment deviations.

6.4.6 Utilities Report

A report giving details of arrangements and working methods in respect of the existing utilities, shall include protection measures, diversions, reinstatements and programme allowances. Details of all utilities to be managed (diverted & protected) for the Works to proceed, is expected. Refer to **Appendix 3**.

6.4.7 Temporary Works Design Report

A separate Design Report for Temporary Works for each structure shall be prepared by the Contractor which provides sufficient information on the design of the Temporary Works to allow the Employer's Representative to assess their effects on the Permanent Works, on train operations during the construction of the Works, and to enable these to be considered in the review of the Definitive Design. The Temporary Works Design Report shall be required before the approval and notification of Definitive Design and Drawings. The Temporary Works Design Report is expected to be a composite of the individual Temporary Works Design Reports as these are prepared as the design progresses.

6.4.8 Hydrology Reports

A report containing the basis for design of the hydrology, for each of the drainage structures, pipes, culverts and bridges shall be submitted with the design. The waterway opening for all waterway structures shall be checked and confirmed as part of the design. Note: As part of the Hydrological Study, (Part 3, Clause 9.0) the Contractor shall undertake hydrological assessment for all structures to confirm the current and future waterway requirements taking into account climate change developments.

6.4.9 Project Programme Review

The Contractor shall, prior to submitting the Definitive Design Submission, review the Project Programme against the current version of the Design Submission Programme.

- a) If the Contractor considers there to be any discrepancies or inconsistencies between the Design Submission Programme and the Project Programme, the Contractor shall submit with the Definitive Design Submission, its proposed revisions to the Project Programme such that the discrepancies or inconsistencies are removed.
- b) The Contractor shall provide details of submissions of the proposed Working Drawings and Documents and their anticipated timing during the Construction Phase.
- c) The Contractor shall identify information required from or actions to be undertaken by the Employer or others and which are necessary to permit the completion of the design of the Permanent Works and the Working Drawings and Documents.
- d) Dates of the receipt required by the Contractor of such information or for the completion of such actions shall be included with appropriate justification.

6.5 DESIGN SUBMISSIONS - REFERENCE DRAWINGS & SHOP DRAWINGS

- 6.5.1 The Reference Drawings and Documents shall be derived directly from the Definitive Design and shall detail and illustrate in full the Permanent Works. The Reference Drawings shall form part of the Working Drawings to be used for construction purposes.
- 6.5.2 Unless otherwise required by the Engineer, the Reference Drawings need not include bar bending schedules, bar reference drawings, fabrication or shop drawings as well as other schedules or erection drawings. Such Shop Drawings are to be provided by the Contractor during the Construction Phase and submitted to the Engineer for review and comment.

6.6 DESIGN SUBMISSIONS - CONSTRUCTION PHASE

- 6.6.1 On the issue of a Notice of No Objection in respect of the Reference Drawings the Contractor shall produce the proposed Working Drawings.
- 6.6.2 The Working Drawings shall either be identical to the Reference Drawings or shall be further drawings and documents developed in accordance with the Reference Drawings such as fabrication and shop drawings, construction installation and erection sequences and the like and all such drawings shall comply with the requirements of the Contract.
- 6.6.3 Prior to submission of the proposed Working Drawings, the Contractor shall endorse the Drawings as "For Construction".
- 6.6.4 If the Engineer so requires, the endorsed original shall be submitted to the Engineer who shall, if he has no objection to the contents of the submission, further endorse the original by stating that he has no objection to the proposed Working Drawings.
- 6.6.5 On the endorsement by the Engineer, the original will forthwith be returned to the Contractor as the Working Drawings.
- 6.6.6 Only the Working Drawings endorsed or those that the Engineer has expressly stated as not requiring his endorsement shall be issued to the Site and the construction of the Works shall be strictly in accordance with these Working Drawings.
- 6.6.7 The Contractor shall finalise details of the proposed method of construction and/or installation and submit such finalised details to the Engineer for review, comment and agreement.
- 6.6.8 As-Built Drawings and Documents endorsed by the Contractor shall be submitted to the Engineer for agreement in accordance with the Conditions of Contract.

6.7 DESIGN SUBMISSIONS - REVIEW PROCEDURES

- 6.7.1 Design submissions shall be reviewed by the Engineer/Employer, over a period of up to twenty-eight (28) calendar days (excluding public holidays), and the Engineer shall co-ordinate the design review by the Employer. The form and detail of the review shall be as determined by the Engineer and will not release or remove the Contractor's responsibility for the design under the contract.

- 6.7.2 The issue of a Notice of No Objection shall be without prejudice to the issue of any future Notices of No Objection.
- 6.7.3 The Contractor shall, prior to the submission of the Design data, obtain all required and/or statutory approvals that relate to that submission including, where appropriate, the approval of the Concerned Government Authorities and Municipalities and utility undertakings, and demonstrate that all required approvals have been obtained.
- 6.7.4 All submissions shall be accompanied by two original copies of a 'Design Certificate' signed by the Contractor and the Designer confirming that the Designs comply with the requirements of the Contract including these Specifications.
- 6.7.5 As-Built drawings and documents shall be submitted to the Engineer progressively as the Works are constructed, for approval.

6.8 DESIGN SUBMISSION PROGRAMME

- 6.8.1 The Contractor shall prepare the Design Submission Programme which is to set out fully the Contractor's anticipated programme for the preparation, submission and review of the Design Packages, the Definitive Design Submission and the Reference Drawings Submissions and for the issue of Notice(s) of No Objection in relation thereto.
- 6.8.2 The Design Submission Programme shall:
- a. be consistent with and its principal features integrated into the Works Programme, and show all relevant Milestones and Key Dates;
 - b. identify dates by and subjects for which the Engineer's decisions should be made;
 - c. make adequate allowance for periods of time for review by the Engineer and other review bodies;
 - d. make adequate allowance for the design and development of specialist works;
 - e. include a schedule identifying, describing, cross-referencing and explaining the Design Packages into which the Contractor intends to divide the Definitive Design and Reference Drawings; and
 - f. indicate the Design Interface and Co-ordination periods for each Interfacing Contractor.
- 6.8.3 The Contractor shall submit the Design Submission Programme to the Engineer within twenty-eight (28) days of the Date of Commencement, and thereafter updated versions thereof at intervals of not more than one (1) month throughout the Design Phase.
- 6.8.4 The Contractor shall submit complete set of documents requested by territorial Act, as well as approved As-Built drawings and certificates for conclusion of the cadastre procedures.
- 6.8.5 All submitted document shall be enclosed with the original 'Design Certificates'.

6.9 CALCULATIONS

- 6.9.1 Unless otherwise required by the Engineer, the detailed calculations relevant to the Definitive Design and Reference Drawings shall be submitted for review with the respective Design Packages or Submissions.

- 6.9.2 The Engineer or representatives of Employer may require the submission of applicable software including in-house software programmes/ worksheets developed by the Contractor, computer input and programme logic for its review prior to the acceptance of the computer output.
- 6.9.3 The Contractor shall prepare and submit a comprehensive set of calculations for the Definitive Design in a form acceptable to the Engineer.
- 6.9.4 Should the design of the Permanent Works be revised thereafter and, such a revision, render the calculations as submitted obsolete or inaccurate, the Contractor shall prepare and submit revised calculations.
- 6.9.5 Similarly, the Contractor shall submit such further calculations as have been prepared in connection with the Reference Drawings.
- 6.9.6 Calculations to be included as part of the submission herein shall comprise the up-to-date calculations in respect of the Definitive Design, the Reference Drawings and such further calculations which the Contractor has prepared during the production of Working Drawings.
- 6.9.7 The Contractor shall submit all calculations necessary to support proposals relating to the construction methods.

6.10 DOCUMENT REQUIREMENTS

- 6.10.1 Drawings shall be prepared generally to A1 size, but to other ISO A sizes where appropriate. **Appendix 7** defines the Drawings and CAD Standards required for drawing preparation and submittal.
- 6.10.2 The Contractor shall submit 8 copies in English and Azeri languages and an electronic version of the Definitive Design and drawings for review by the Engineer. After receipt of "No Objection" from the Engineer's Representative, the Contractor shall submit 8 copies of the design and drawings for the use of the Engineer/Employer.
- 6.10.3 The submission of drawings may be by CAD Media files; **Appendix 7** specifies the drawing submission requirements for CAD Media files. The approval of drawings shall however only be certified on the paper copy.

6.11 DOCUMENT REQUIREMENTS

- 6.11.1 Drawings shall be prepared generally to A1 size, but to other ISO A sizes where appropriate. **Appendix 7** defines the Drawings and CAD Standards required for drawing preparation and submittal.
- 6.11.2 The Contractor shall submit 8 copies in English and Azeri languages and an electronic version of the Definitive Design and drawings for review by the Engineer. After receipt of "No Objection" from the Engineer's Representative, the Contractor shall submit 8 copies of the design and drawings for the use of the Engineer/Employer.
- 6.11.3 The submission of drawings may be by CAD Media files; **Appendix 7** specifies the drawing submission requirements for CAD Media files. The approval of drawings shall however only be certified on the paper copy.

7 TRACK DESIGN CRITERIA

7.1 TRACK STRUCTURE

The superstructure of the railway shall include all its elements situated above the upper level of the ground bed (rails, fastening system, sleepers, ballast).

7.1.1 Rails

7.1.1.1 General

- i. The Contractor's designed Top of Rail shall be a similar level (+/- 100mm) to current Top of Rail, and shall maintain the current height from Top of Rail to platform level at Stations.
- ii. All the rails to be laid in the main tracks shall be of type R-65 of grade R260 or R350HT, while the rails for the sidings (Track 3 & Track 4) will be second-hand ultrasonic tested R-65 rail.
- iii. All new R-65 rail shall be manufactured, tested and supplied in compliance with EN 13674-1:2011.
- iv. All type R-65 rails for the main tracks shall be brand new and especially manufactured for this Project and supplied directly from the manufacturer. Tenders offering to supply rails that have been produced in the past shall be rejected.
- v. All new R-65 rails shall have one manufacturer. Tenders offering to supply rails manufactured by more than one manufacturer shall be rejected.
- vi. The type R-65 rails for the sidings may be second-hand rails; the Contractor may re-use (upon the appropriate processing) the existing track dismantled by him within the scope of the present contract, however, in this case the materials re-used shall comply with the standards for second-hand track materials and each of the second-hand rails supplied shall have passed ultrasonic examination.
- vii. Representatives of the Employer shall be present at the production processes and tests of the total quantity of rails required.
- viii. The steel used for the manufacture of rails shall be Basic Oxygen steel or electric arc furnace steel, vacuum degassed, in the case of electric arc steel a secondary arc refining facility is mandatory.
- ix. Rail steel shall be of quality Grade R260 in straight track section or section with curves above 3,000 m radius. For all track sections with curves of 3,000 m radius or below a rail steel grade of R350HT shall be used.
- x. The Tenderer shall indicate in his Tender the nature and principal characteristics of the steel and rail manufacturing processes and these shall not be altered during contract performance.
- xi. The manufacturer of the rails shall operate an independently approved and audited quality assurance system, conforming to the requirements of ISO 9002 or equivalent. (Note: All Bidders shall include in the Tender documentary evidence proving this requirement.)
- xii. All rails on the main line (including Track 3 & Track 4) shall be skim ground in the track after construction works have been completed and prior to the commissioning of the whole of the Works. (See Section 7.3)
- xiii. One month prior to the expiry of the Defects Notification Period, the whole of the track (including Track 3 & Track 4) shall be ground to provide an agreed rail head profile. The rail head profile shall be pre-agreed with the Employer. (See Section 7.3)

7.1.1.2 Steel Parameters

- i. The chemical composition of the steel shall conform to UIC 860 or EN 13674.
- ii. Steel cleanliness shall be in line with DIN 50602/EN10247 or equivalent with a K3 less than 10 for 95% of the make and less than 20 for the remaining 5%.

7.1.1.3 Rail Parameters

- i. The Tenderer shall include in his tender a drawing of the master rail profile;
- ii. All rails supplied for the project shall be without any fish bolt or other holes;
- iii. The standard length of the R-65 rails manufactured and supplied shall be as long as is practical to manufacture and transport. Preference will be given to the supply of long rails up to 150m in length. The absolute minimum length for any rail supplied shall be 25 metres. No intermediate rail welding is permitted.
- iv. Minimum length of closure rails shall be 12 m to 12.5 metres;
- v. The minimum length of long welded rail (LWR) to be installed in the track is 300 metres;
- vi. All dimensions of the rail cross - section shall have tolerances as listed in (AzDTN/GOST, SNIP);
- vii. The flatness of the rails shall be as follows:
 - (a) Vertical flatness of the body of the rail at a 3.00 m basis shall not exceed 0.4 mm; ("Body" is that part of the rail, which is situated at least 2.00 m away from each front edge of the rails).
 - (b) Horizontal flatness of the body of the rail (measured 5 to 10mm below the gauge corner on the side of the head) at 1.50m basis shall not exceed 0.6 mm.
- viii. The straightness of the rails shall be as follows:
 - a) Vertical straightness of the rail ends at 1.50m basis shall not exceed 0.5 mm; The Rail ends are those two parts of the rail, which are up to 2.00 m from each front edge of the rail.
 - b) Horizontal straightness of the rail ends at a 1.50 m basis shall not exceed 0.7mm.
- ix. Residual stresses in the finished rails shall not be more than 250 N/mm² in the foot area of the rail.
- x. The rails must be free from all detrimental defects having an unfavourable effect on the behaviour of the rails in service. Such defects include, among others: surface defects, cracks of all kinds, flaws, piping, or lack of metal. For checking against all these defects and for other purposes all rails shall be checked by ultrasonic and rail foot flaw detection equipment.
- xi. The mass per 1.00 m of rail length shall be in conformity with AzDTN/GOST, SNIP.

7.1.1.4 Marking of Rail

- i. All rails shall be marked according to AzDTN/GOST, SNIP.
- ii. In addition, all rails shall have the following mark in relief: the number of the month and year of manufacture in numerals.

7.1.1.5 Tests and Acceptance

- i. The representative(s) of the Employer/Engineer shall be entitled to observe, by day or night, the method of manufacture and to be present at all tests relating to all casts for his railway and to examine the results obtained from such tests.

- ii. The representative(s) of the Employer/Engineer shall be entitled to carry out all necessary checks at the manufacturer's premises to ensure that the manufacture is strictly in accordance with the stipulated conditions.
- iii. The supervision shall be conducted in such a way that it does not interfere with the normal manufacturing operations without valid reasons.
- iv. All travel, accommodation (including meals) for the presence of up to three (3) representatives of the Employer/Engineer to the manufacturer's premises shall be at the expense of the Contractor.
- v. The Contractor shall be bound to inform and invite the Employer/Engineer for acceptance at least 30 days in advance of the date anticipated for the beginning of the rolling schedule.
- vi. Before rails manufacture, the successful Tenderer shall submit for approval to the Employer/Engineer, at his own expense, drawings of all gauges required for checking the rails' geometrical parameters.
- vii. Prior to the beginning of the first rolling schedule the successful Tenderer shall submit to the Employer/Engineer two sets of female and male gauges, conforming to the theoretical outline of rail's cross section to be manufactured, together with two sets of plus and minus limit gauges in accordance with the above listed maximum tolerances.
- viii. These gauges shall be stamped after approval by the representative of the Employer/Engineer and one set of all gauges shall remain in the possession of the Employer/Engineer during the period of the contract performance.
- ix. Only gauges bearing the stamp of the Employer/Engineer shall be valid for checking purposes.
- x. The Tenderer shall include in his tender a detailed description of all test methods, facilities and equipment used to prove all the above listed steel and rail parameters and others which he considers important for the quality of steel and rails. Tenders without such information can be rejected.
- xi. Tests carried out to prove the quality of steel and rails shall include, among others, tensile tests, macroscopic tests, Brinell hardness, fracture tests, fatigue tests, residual tests in rail foot.
- xii. The nature of these tests and the test samples to be taken; the extent of the tests, the results to be obtained and the check tests shall be in conformity with AzDTN/GOST, SNIP.
- xiii. All tests and the results to be obtained not mentioned in the quoted Leaflet or the present specifications shall be proposed by Tenderer in his tender.

7.1.1.6 Guarantee

For the guarantee of the rails item 3.1 - Guarantee of UIC Leaflet 860 (and AzDTN/GOST, SNIP) shall be applied.

7.2 RAIL WELDING

7.2.1 General

Rail for all main line track, including the turnouts, shall be welded into continuous strings using the electric flash-butt welding process using a stationary or mobile machine at a welding factory or in the Temporary Staging Area – TSA, or on-track. The flash-butt welder at the Temporary Site Facilities or an on-track mobile flash-butt machine shall have the capability of adjusting rail heads for individual welds.

Rail within turnout limits shall be welded using an accepted thermit welding or flash-butt welding process.

On completion of the construction activities and within three (3) months from commencement of the Defects Notification Period the Contractor shall pass ownership of two (2) of the electric mobile flash-butt welding sets used on the Contract to the Employer (See **Appendix 22** for details).

7.2.2 Alignment and Finishing

Vertical alignment shall provide for a flat running surface. Any difference of height of the rails shall be in the base.

Horizontal alignment shall be adjusted in such a manner that any difference in the width of heads or rails shall be divided equally on both sides of the head.

- i. Horizontal offsets shall not exceed 1 mm in the head and 3mm in the base.
- ii. Combined vertical offset and crown camber shall not exceed 0.2mm per 1000mm base.
- iii. Combined vertical offset and dip camber shall zero. There shall be no dips.
- iv. Combined horizontal offset and horizontal kink camber shall not exceed 0.5mm per 0.3m.

The completed weld shall be finished by mechanically controlled grinding. All heavy grinding shall be performed on the hot metal, immediately following welding, to prevent metallurgical damage.

The Contractor shall finish the weld metal at the crown of the rail to within **plus 0.20mm to minus 0mm** of the adjoining rail and the sides of the rail to ± 0.25 mm. The weld metal at the bottom and sides of the rail foot shall be finished to within ± 0.25 millimetre of the adjoining rail. The remainder of the rail section shall be finished to within plus 6 mm minus 0 mm of the adjoining rail.

All notches created by offset conditions or twisted rails shall be eliminated by grinding to smoothly blend together the deviations. All fins due to grinding drag and cracks shall be removed.

7.2.3 Electric Flash-Butt Welding of Rail

As part of the Concept and Preliminary Design Review Submission the Contractor shall submit full details of the welding machine and welding process he proposes to use. These shall include but shall not be limited to the following:

- i. Welding procedure, equipment description, calibration methods, rail shearing method, and rail straightening method;
- ii. Cooling procedure for preserving the hardness of premium rails;
- iii. Certification of welding machine operators;
- iv. Procedure for detecting defective welds;
- v. Procedure for replacing defective welds;

7.2.4 Flash-Butt Weld Preproduction Samples

Prior to making any welds on-site, the Contractor shall produce evidence of the competence of his welding machine operators, which shall include evidence of a minimum of one year's experience of similar work on a similar machine.

In the presence of the Engineer, each welding team shall produce six specimen welds for testing. If welding machine operators are changed during the course of the contract, the Contractor shall in the presence of the Engineer produce another six specimen welds for testing from the team having the new operator(s).

The six specimens shall comprise two specimens of the each of the following combinations:

- i. Head hardened (R350HT) with standard (R260) rails welded together;
- ii. Head hardened with head hardened rails welded together;
- iii. Standard with standard rails welded together.

In the specimens containing premium rails, the Contractor shall minimise the longitudinal variations in surface hardness across the weld by controlling the cooling of the weld using purpose-made air-quenching equipment.

The Brinell hardness imprints on the weld shall be measured on longitudinal lines at the following rail depth (see Figure below):

- a. at 5mm and 10mm below the head of the rail and;
- b. at the centre of the web and;
- c. at the foot of the rail.

Spacing of the imprints shall be at 2.5mm centres or as accepted by the Engineer.

The measurements obtained shall be recorded and presented in graph and numeric form. The variation in hardness values between the unaffected parent material (at least 20mm in length) and the adjoining Heat Affected Zone (HAZ) shall be at $\pm 10\%$; where the hardness values of the HAZ shall be taken at 5mm away from the HAZ/parent material interface and at 2.5mm away from the fusion zone centre. If this figure is not achieved, the Contractor shall make a new weld using an adjusted cooling regime.

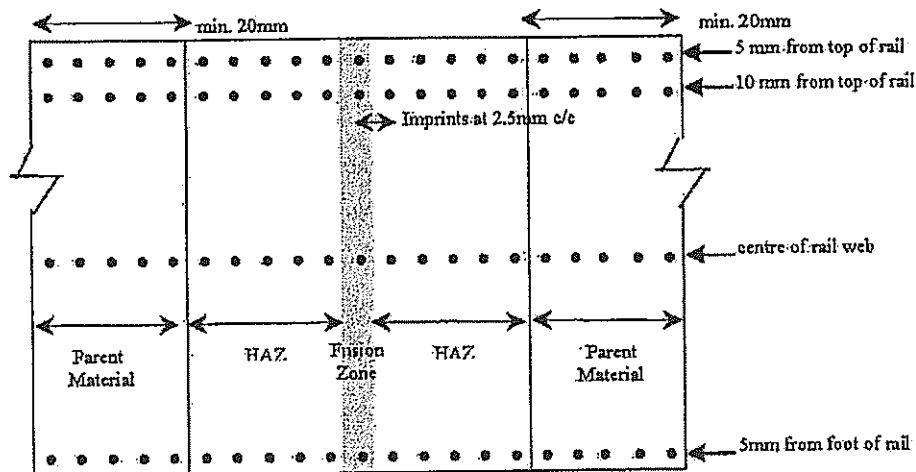

Macro-etch Examination Test

Each specimen weld shall be accompanied by a welding record as described below and shall be ultrasonically tested and inspected by magnetic particle testing as described below.

One of each type of weld shall be subjected to slow bending tests and one shall be longitudinally cross sectioned and macro-etched.

The slow bend specimen (length min. 1200mm) shall be mounted horizontally on two point supports 1000mm apart with the weld midway between them.

The Contractor shall propose the testing method including the load, deflection etc. in the Design Report. Such details shall be based on the requirements of the national standards, СТО РЖД 1.08.002; GOST R 51685; EN 14587-1.

7.2.5 Flash-Butt Weld Production

The Contractor shall remove all mill scale on the head and base of the rail down to white metal for a length of 150 millimetres from the rail end or as recommended by the manufacturer of the welding machine.

The Contractor shall remove burrs and prepare the surfaces as recommended by the manufacturer of the welding machine where the welding current electrodes contact the rail.

The Contractor shall shear off the upset weld metal while the weld metal is still plastic. If one or both of the rails being welded together is head hardened rail, the Contractor shall minimise the longitudinal variations in surface hardness across the weld by controlling the cooling of the weld using purpose-made air-quenching equipment.

The Contractor shall be permitted to employ post-weld straightening only whilst the surface temperature of the weld is above 260 degrees C.

The Contractor shall inspect every tenth (10) weld by magnetic particle testing in national or other international standard and by ultrasonic testing in accordance with national or other international standard. Each completed weld shall have full penetration and complete fusion and be entirely free of injurious flaws. Refer to СТО РЖД 1.11.002 (STO RR 1.11.003)

After every 200 welds the Contractor shall prepare a test weld and have it delivered to a laboratory accepted by the Engineer for radiographic testing, to monitor the quality of the welding procedure.

7.2.6 Weld Production Records – Flash-Butt Welding

During production, a recorder shall be attached to the welding machine which shall plot platen movement and current impulses against time. The Contractor shall carefully examine the plot after each weld and if the plot indicates characteristics which depart significantly from the expected characteristics the weld shall be considered defective and shall be immediately replaced. Accepted characteristics of plot platen movement and current impulses against time shall be submitted to Engineer for reference.

At the end of each machine shift, copies of the plots for each weld shall be delivered to the Engineer together with the information requested on the specimen Welding Record Form. All welds, including defective welds which have been cut out, shall be included in the daily records.

7.2.7 Thermit Welding of Rail - General

As part of his Concept and Preliminary Design Review submissions the Contractor shall submit full details of the welding process he proposes to use. These shall include but shall not be limited to the following:

- a) Equipment description;
- b) Certification of welding crews;
- c) Procedure for detecting defective welds;

- d) Procedure for replacing defective welds (wide-gap welding shall not be permitted);
- e) Minimum and maximum gap between rail ends (based on the method used);
- f) Method used for placing, fixing, and maintaining the rails in alignment and position during welding;
- g) Method used for preheating, if required, including item and temperature;
- h) Tapping procedure including the minimum time required to cool the weld under the mould insulation;
- i) Method used, including a description of special tools and equipment, for removing excess weld metal and finishing the weld to the final rail head contour.

7.2.8 Preproduction Samples – Thermit Welding of Rail

Prior to making any welds on-site, and again at intervals of not less than four months, the Contractor shall produce evidence of the competence of his welding crews. In the presence of the Engineer and a manufacturer's representative experienced in thermit welding, each crew shall produce two specimen welds for testing in accordance with EN14730. If any one or more member(s) of a welding crew is changed during the course of the contract, the Contractor shall in the presence of the Engineer produce another two specimen welds for testing from the crew having the new members(s).

The welds shall be tested for flash-butt welds. For standard to head hardened rail welded joints, the deflection shall not be less than 14mm at rupture. For head hardened to head hardened rail welded joints, the deflection shall not be less than 10 mm at rupture.

7.2.9 Production – Thermit Welding of Rail

All rail welds shall be made under the direct supervision of an experienced welding foreman or supervisor. In addition, a manufacturer's representative experienced in thermit welding shall witness the making of at least the first 25 thermit welds and thereafter witness at approximately four-monthly intervals another 25 welds being made.

Each qualified welder shall be provided with an identification stamp. After completion of each weld, the welder shall apply the stamp to the rail web in a way that is readily identifiable.

Before the mould is fitted, the ends of the rails to be welded shall be cleaned to remove all grease, oil, dirt, loose scale, and moisture.

The rail gap and alignment shall be held without change during the complete welding cycle, including cooling.

The rail ends shall be preheated as required by the weld manufacturer to ensure full fusion of the weld metal to the rail ends without cracking of the rail or weld.

The moulds shall be left in place after tapping for sufficient time to permit complete solidification of the molten metal and slow cooling to prevent cracking and provide a completed weld with the proper hardness.

Shearing of surplus weld metal shall be performed before cooling of rail. The completed weld shall be finished by mechanically controlled grinding.

The Contractor shall be permitted to employ post-weld straightening only whilst the surface temperature of the weld is above 260°C.

The Contractor shall inspect every weld by magnetic particle testing in accordance with national or other international standard (e.g. CTO РЖД 1.11.002 (STO RR 1.11.002)) mentioned and by ultrasonic testing in accordance with national or other international standard. Each completed weld shall have full penetration and complete fusion and be entirely free of injurious flaws.

After every 200 welds the Contractor shall prepare a test weld and have it delivered to a laboratory accepted by the Engineer for radiographic testing, to monitor the quality of the welding procedure.

7.2.10 Alignment and Finishing – Thermit Welds

Vertical alignment shall provide for a flat running surface. Any difference of height of the rails shall be in the base.

Horizontal alignment shall be adjusted in such a manner that any difference in the width of heads or rails shall be divided equally on both sides of the head.

- a) Horizontal offsets shall not exceed 1 mm in the head and 3mm in the base.
- b) Combined vertical offset and crown camber shall not exceed 0.2mm per 1000mm base.
- c) Combined vertical offset and dip camber shall zero. There shall be no dips.
- d) Combined horizontal offset and horizontal kink camber shall not exceed 0.5mm per 0.3m.

The completed weld shall be finished by mechanically controlled grinding. All heavy grinding shall be performed on the hot metal, immediately following welding, to prevent metallurgical damage.

The Contractor shall finish the weld metal at the crown of the rail to within plus **0.20mm to minus** 0mm of the adjoining rail and the sides of the rail to ± 0.25 mm. The weld metal at the bottom and sides of the rail foot shall be finished to within ± 0.25 millimetre of the adjoining rail. The remainder of the rail section shall be finished to within plus 6 mm minus 0 mm of the adjoining rail.

All notches created by offset conditions or twisted rails shall be eliminated by grinding to smoothly blend together the deviations. All fins due to grinding drag and cracks shall be removed.

7.2.11 Test Records – Thermit Welds

Records of each weld shall be kept containing the information requested on the specimen Welding Record Form. At the end of each shift copies shall be delivered to the Engineer. All welds, including defective welds which have been cut out, shall be included in the daily records.

After every 200 welds the Contractor shall prepare a test weld and have it delivered to a laboratory accepted by the Engineer for radiographic testing, to monitor the quality of the welding procedure.

7.2.12 Inspection and Testing – Thermit Welds

As part of his Concept and Preliminary Design Review submission the Contractor shall submit full details of the thermit weld testing arrangements he proposes to adopt. These shall include but shall not be limited to the following:

- i. Procedure for dry powder magnetic particle inspection;
- ii. Ultrasonic inspection procedure, equipment description and calibration methods;

- iii. Daily calibration of ultrasonic inspection equipment;
- iv. Name of laboratory and procedure to be utilised in radiographic testing;
- v. Training and certification of ultrasonic magnetic particle and radiographic test personnel.

7.2.13 Test Methods – Thermit Welds

The Contractor shall provide evidence of the training and competence of the testing personnel.

Magnetic Particle Testing

Testing shall be conducted as soon as practical after the rail temperature drops below 425 degrees C. Particles shall form into a regular longitudinal pattern indicating homogeneity of the weld and freedom from defects, surface irregularities and internal discontinuities.

Ultrasonic Testing

Prior to testing of welds, all equipment operators shall be examined to confirm their competence. The examination shall be conducted with a calibration rail serving as the test specimen. To qualify for acceptance, each operator shall demonstrate that he can locate all the holes in the calibration rail. The examination shall be witnessed by an independent technician provided by the Contractor, certified and experienced in ultrasonic examination of rail welds.

Testing equipment shall comprise a pulsed echo instrument purpose-made for the inspection of rail welds with calibrated decibel gain control in minimum increments of 2dB, operating in the range 1-5 MHz. The equipment shall be capable of detecting a 1.2 mm diameter bottom hole 165 mm below top of rail in a non-welded portion of the rail. The equipment shall be calibrated on a 6.3 mm hole horizontally through the rail neutral axis as the "reference response".

The equipment shall be fitted with a CRT screen and scale and shall be capable of generating a calibrated paper tape trace to record accurately the CRT screen indications when a non-compliant weld is suspected.

The Contractor shall supply standard calibration blocks of rail steel for primary reference response, to construct distance-amplitude correction curves and for calibration checks. He shall also supply a 500mm long R260 calibration rail predrilled with calibration holes and simulated faults for examining the competence of equipment operators. The Contractor shall design a calibration rail acceptable to the Engineer.

The test procedure shall be in accordance with the instructions of the equipment manufacturer.

The calibration of the equipment shall be checked at the beginning of every day and after every four hours of use thereafter.

If any point on the distance-amplitude curve has changed by more than 20 percent since the immediately preceding check, all results since then shall be void and all welds retested. If the curve has moved on the sweep line by more than five percent, all non-complying welds since last calibrating check shall be retested.

Where a non-compliant weld is suspected, the Contractor shall make a permanent trace recording and shall paint the rail web on both sides across the weld.

7.2.14 Acceptance of Thermit Welds

Welds showing a response at any level that is identified as a crack or lack of fusion shall not be acceptable.

Welds showing a response that is less than 50 percent of the primary reference level shall be acceptable.

Welds showing a response greater than 50 percent but that do not exceed the primary reference level are acceptable, provided that all of the following apply:

- i. The defects are evaluated as slag or porosity;
- ii. The largest defect does not exceed 4.5mm in its largest dimension;
- iii. The total area of the defects does not exceed 58 mm².
- iv. The sum of the greatest dimension of defects in a line does not exceed 9.5 mm.
- v. Welds showing a response that exceeds the primary reference level shall be rejected.
- vi. Rails showing evidence of electrode burns will be rejected.

7.2.15 Consolidated Thermit Welding Reports

For each weld, the welding records and test records shall be presented in a format acceptable to the Engineer.

7.2.16 Delivery, Storage and Handling – Thermit Weld Kits

Thermit welding material, including moulds, shears, and other hardware, shall be stored in a covered and dry location.

Each welding materials package shall consist of a complete portion of welding materials as necessary to execute one thermit weld.

The portions shall be packed in sea watertight sealed bags marked with identification: type of weld, type of rail, type of rail steel. They shall remain in sealed containers until they are used. Only portions from undamaged bags shall be used to produce field welds

7.3 RAIL - SKIM and PROFILE GRINDING

7.3.1 Skim Grinding of Rail

On completion of the Works, but as part of the testing and commissioning phase, and before the start of the Defects Notification Period but before the beginning of revenue services, all running rails in the main running lines shall be skim ground in accordance with EN13231-3 to remove rolling roughness and surface defects.

The rail on Track 3 and Track 4 at stations shall also be skim ground.

For skim grinding a specific on-track grinding machine (minimum 8 stones) shall be used. The characteristics of this machine will be provided to the Engineer before the beginning of works.

All grinding debris shall be promptly removed by suction or by magnetism or other system which could lead to the track to be left clean, especially in the vicinity of fastenings, to minimise the risk of stray currents occurring.

The grinding shall be to the R-65 crown profile. There shall be no asymmetric grinding on curves. During rail grinding, rail profile shall be checked frequently by using templates.

Typically, 0.2mm of steel shall be removed. The tolerances shall be +/- 0.1mm longitudinally and +/- 0.3mm transversely.

In GIRJ, MIRJ and turnout areas, particular attention shall be applied to ensure there will be no residual metal fillings after grinding. The switch rail and the crossing (frog) shall be excluded from the skim grinding.

Prior to skim grinding, the railway equipment must be protected by using special fabric or thermal blanket to protect it from exposure to high temperature grinding debris.

7.3.2 Profile Grinding of Rail

One month prior to the expiry of the Defects Notification Period, the whole of the track (including Track 3 & Track 4) shall be ground to provide an agreed rail head profile.

The rail head profile shall be pre-agreed with the Employer.

Typically, 0.2mm to 0.5mm of steel shall be removed. The tolerances shall be +/- 0.1mm longitudinally and +/- 0.3mm transversely.

In GIRJ, MIRJ and turnout areas, particular attention shall be applied to ensure there will be no residual metal fillings after grinding. The switch rail and the crossing (frog) shall be excluded from the profile grinding.

Prior to profile grinding, the railway equipment must be protected by using special fabric or thermal blanket to protect it from exposure to high temperature grinding debris.

7.4 JOINTLESS TRACK - CWR (CONTINUOUS WELDED RAILS)

7.4.1 General

- i. Rails and switch rails shall be welded into jointless track (CWR) for the entire length of the main lines 1 & 2.
- ii. Tracks 3 & 4 shall be long welded rails (up to 300m) with mechanical joints (6 hole plates per rail). Turnouts on tracks 3 & 4 shall not be continuously welded rail.
- iii. Jointless track means railway track with rails continuously welded to such length that even when reaching the maximum or the minimum temperature for the corresponding climatic area the middle part of the rails always stays immovable (fixed).
- iv. Breathing ends means the two final segments of the jointless track, which may change their length under the influence of temperature changes.
- v. Temperature at jointless track laying means the rail temperature measured at the completion of fastening (the final installation) of the jointless rails to the sleepers.
- vi. Neutral temperature of the rails means the rail temperature at which temperature changes do not cause excessive stress in the rails of the jointless track. The Contractor shall propose the neutral temperature as part of the design, for agreement by the Engineer/Employer. The neutral temperature shall take into consideration climate change developments.
- vii. Temperature interval for jointless track laying means the interval defining the temperatures at which the jointless track can be laid without a pre-stress (artificial extension or shortening of the rails).
- viii. Neutralization of the stress in the rails means the stress release of the rails from the tension or compression caused by temperature changes.
- ix. For the construction of the jointless track the Contractor shall prepare a methodology, maintenance manual, and programme, which shall be approved by the Engineer and the Employer and shall be in accordance with UIC Leaflet 720 R Laying and Maintenance of CWR Track and the regulations stated in **Appendix 16**

7.4.2 The Temperature Intervals

The temperature intervals for jointless track laying are as follows:

SECTION	RAIL TYPE	TEMPERATURE INTERVAL
GIL-GIL-CHAY - SUMQAYIT	R-65	To be designed and Agreed.

7.4.3 Length of Rails used for the Jointless Track

- i. The minimum length of supplied rail shall be from 25 metres to 100 metres. The use of rails with holes or tempered ends shall not be allowed.
- ii. The primary rails for the jointless track shall be welded using stationary or mobile flash-butt welding machines to a length not less than 300 metres prior to transporting to site.
- iii. All flash-butt welds on the 300 metre long rail string shall be tested as per the requirements of this Specification and passed before transportation of the 300 metre long rail string to site.
- iv. The transportation of the long-welded rails from the welding base to the site shall be done by a specialist rail vehicle ensuring the necessary safety.
- v. After the transportation of the rails to the site they shall be welded together in-situ using mobile flash-butt welds to EN 14587 and/or aluminothermic welds to EN 14730.
- vi. The limits of tolerance for the rails' geometry in the zone of the welding (for all weld types) shall be:
 - a. on the upper surface of the rail: minus 0.00 mm & plus 0.20 mm measured at base length 1000 mm;
 - b. 14 mm under the upper surface of the rail head: – 0.3 mm to +0.3 mm.

7.4.4 Breather/Buffer Ends

- i. At the stations on track 3 & 4, the jointless sections of the R-65 rail shall end in a breather / buffer end in a straight section of line.
- ii. The location of a breather / buffer end in a transition, circular curve, or turnout, is not allowed.
- iii. Breather/Buffer ends with normal length of 30 m shall be laid at the ends of the jointless sections in the following cases:
 - a) before segments of jointed sections - one segment;
 - b) on both sides of the turnouts in case they are not welded and are not a part of the jointless track.

7.4.5 Jointless Track on Structures

- i. Jointless track can be laid on bridges with a ballast bed and with pre-stressed monobloc concrete sleepers if the bridge is in a straight or a curve with radius larger than 1000 m. The requirements for jointless track on these bridges are as for normal jointless track. Refer to UIC 774-3 for compliance.
- ii. A jointless section of track crossing a bridge shall not end within 100 m of the bridge abutments.
- iii. Rails' welds are not permitted within 6m of a bridge abutment or the guard ballast walls of the abutments;

7.4.6 Neutralisation/Destressing of the Rails

- i. Neutralization shall be carried out when:
 - a) the jointless track is laid temporarily at a temperature out of the temperature range for jointless track laying;

- b) it is found out that under the influence of construction activities the neutral temperature has changed and does not coincide anymore with the laying in neutral temperature;
 - c) there is a necessity of construction works connected with the weakening of the ballast bed or considerable movement of the track's vertical or horizontal position and in all cases of danger of the jointless track's disruption;
 - d) in any other case required by the provisions of the ADY or relevant international standards.
- ii. Neutralization shall be carried out on segments not longer than 1000 m for straight track and 600 m on curves.
 - iii. Neutralisation shall be carried out without a joint in the curve transition (i.e. between the TS to SC) or in the last 100 m of the jointless track.

7.4.7 Connection with Rails of different Type

The connection between the R-65 rail and the existing rails shall be done with two (2) distinct types of rail, welded in the workshop properly with two (2) pieces of 9 m/12.5 m each and grinding, accordingly.

7.4.8 Welding of the Turnouts

- i. All turnouts, in the main line track shall be welded and shall be part of the jointless track.
- ii. Turnouts in tracks 3 & 4 at Stations shall be refurbished turnouts of the non-welded type. The Contractor shall refurbish these turnouts using good quality spares from recovered turnouts.
- iii. The diversion section of turnouts R-65 type 1/11 and/or 1/9, where they connect the main tracks 1 and 2 shall be welded forming part of the jointless track.
- iv. The welding of turnouts will be done after the preparation of a methodology and programme by the Contractor and having received an approval from the Engineer/Employer. The requirements of the turnouts' producer shall also be observed.

7.5 HORIZONTAL ALIGNMENT

The design and installation of the track horizontal alignment shall comply with National Standards and UIC703, EN13803 and EN13231

7.5.1 Radius of Curves

The alignment of the track rehabilitation shall follow the existing Right-of-way (RoW) and shall be based on the given design criteria and train operation speeds. The Contractor shall study alignment modifications within the RoW, with the aim to avoid unnecessary curves (e.g. Line 1 & 2 have several curves to widen the track centre distance in the areas of bridges and other locations) to enhance operational aspects, track maintainability and passenger comfort.

Desirable minimum curve radius shall be between 1,500 m and 1,000 m radius, but with the constraint, in any case, to be in the ADY's Right-of-way (ROW) including track, embankments or cuts, lineside drainage, access roads and fencing.

7.5.2 Alignment Design Parameters

To ensure sufficient damping of vehicle body oscillations, the minimum lengths of the alignment elements (straight sections, transition curves, circular curves) to be established on the open line, as well as cant, cant deficiency and rate of change of cant deficiency are indicated in the table below. The distances being measured along the centre line of the reference point of transition curves.

ELEMENTS OF THE ALIGNMENT (Length L in m)		(L. in metres & V. in km/hr)
Curve design	Pure circular	<i>Any Length</i>
Transition Curves from tangent to circular	Determined by Clothoid Spiral	<i>Minimum length $L_t = 50m$</i>
Minimum Standard Values	Plain Curve, straight between two (2) curves of similar or opposite direction.	$L = \frac{V}{2} + \text{Transition } L_t$
Minimum Exceptional Values	Plain curve.	$L = \frac{V}{2} + L_t$
	Straight between two (2) curves of similar direction.	$L = \frac{V}{2} + L_t$
	Straight between two (2) curves of opposite direction.	$L = \frac{V}{2} \text{ or } 60 m (\text{min.}) + L_t$
Track Cant	Measured from low rail	<i>Maximum 150mm</i>
	<i>Track Cant 'U' = 12.87 x V² / R</i>	
Cant deficiency	Passenger Trains	<i>120mm</i>
	Freight trains	<i>80mm</i>
Rate of change of cant deficiency		<i>35mm per second</i>

7.5.3 Gauge and Expansion in Curves

7.5.3.1 Normal Gauge

Gauge is the distance between the two (2) rails of the track measured perpendicularly to the track's axis at 14 mm from the top of the rails. The normal gauge will be 1520 mm.

7.5.3.2 Gauge Widening in Curves

- i. The normal gauge shall be widened in curves of the railway track at 5mm intervals depending on the radius as follows:

Radius (m)	180 < R < 250	250 < R < 300	R > 300
Widening (mm)	10	5	0

- ii. Gauge widening shall be done in the full amount of railway curves in the distance between the stations, as well as in all station tracks, no matter if these curves do or do not have elevation or transitional curves.

7.6 VERTICAL TRACK ALIGNMENT

7.6.1 Gradients

- i. The present gradient of the line shall be respected, accordingly.
- ii. For the rehabilitated line, the maximum gradient for longitudinal profile with mixed traffic will be 13.5‰.
- iii. The gradients for longitudinal profile of the track alongside platforms in passenger stations cannot be more than 1.5‰ (1.5mm per meter).

7.6.2 Vertical Curves

- i. For speed of V = 154 km/hr it is advisable to introduce a vertical (circular) curve between two gradients in the longitudinal profile, when the difference in gradient is > 4.0‰.

- ii. The recommended radius of the curve at the crest shall be 7000 m ($0.35xV^2$).

7.6.3 Minimum Length of Vertical Elements

The minimum length of vertical curves and sections of constant gradient between vertical curves is as follows:

$$L(m) = \frac{V}{2} \text{ with } V \text{ in km/hr}$$

7.6.4 Overlapping Horizontal and Vertical Curves

It is strongly recommended for reasons of comfort and future maintenance to not combine a horizontal curve with a vertical curve.

A vertical curve is not permitted in the transition section of a horizontal curve.

7.6.5 Pre-Stressed Monobloc Concrete Sleepers

7.6.5.1 Laying the Sleepers

The number of sleepers in 1 km of railway track with rails of type R-65 shall be defined according to the category of the line and shall not be less than 1840 sleepers in straight track and curve with radius ≥ 300 m where the railway track is joint less and 2000 sleepers in curve with Radius < 300 m.

7.6.5.2 Technical Requirements

- i. The pre-stressed sleeper shall meet the requirements of internationally accepted standards (UIC 713, EN 13230, GOST)
- ii. The sleeper shall meet the following design principles:
 - a) Gauge (at 14 mm from the top of the rail) 1 520 mm;
 - b) Type of rails R-65;
 - c) Form of the bottom surface of the sleeper decreasing in width;
 - d) Slope of the rail seats shall provide for a rail inclination of 1:40;
 - e) Maximum speed of passenger trains 200 km/hr for R-65;
 - f) Maximum axle load 25.0 tonnes (250 kN)/axle;
 - g) Length of sleeper max. 2 700 mm;
 - h) Width of sleeper max. 300 mm;
 - i) Weight of sleeper 310 kg \pm 10kg;
 - j) Height of the cross section under the rails is ≤ 220 mm;
 - k) Area of the bottom surface min. 0.680 m²;
- iii. The sleeper shall have tolerances in the length, width and height max. ± 5 mm.
- iv. The rail seat sizes and distance between them shall have maximum tolerances of +1.5mm and -0.5 mm.
- v. The rail bearing surface of the sleeper shall be flat to within 0.5 mm per 100mm. Relative twist between the two rail seats is allowed 0.5mm per 100mm.
- vi. The surfaces shall be smooth, though the side surfaces may have cavities with a depth of not more than 5 mm and length not more than 10 mm. Cavities in the rail seat area may have depth of not more than 2 mm with protrusions with a height of no more than 1mm.
- vii. The sleepers must be supplied with documents, which shall include evidence about the following tests and the appropriate results that have been carried out on the proposed sleepers:
 - a) Rail seat positive and negative moment tests performed by static and dynamic loads;
 - b) Sleeper centre positive and negative moment test performed by static and dynamic loads;
 - c) Fastening insert pull-out test;

- d) Two (2) impact load tests on every sleeper tested showing individual transversal cracks on the whole width and possible scraps of concrete;
 - e) Test for concrete quality and tension strength tests.
- viii. The sleepers shall be equipped with plastic dowels if constructed to be fastened with screws.
- ix. The concrete shall have strength class not less than B 70 type sleeper.
 - a) The compressive strength shall be at least 50 MPa after 28 days.
 - b) The bending tensile strength shall be at least 62 MPa at 28 days.
 - c) The compressive strength of the concrete at transfer of the pre-stressed force shall be at least 35 MPa.
- x. The concrete shall have freeze resistance F200.
- xi. The cement shall be GEM I 52.5 or GEM I 52.5 R according to ENV 197-1-2011 or a cement with equivalent properties.
- xii. 24 hours after the production the sleeper shall be capable of bearing bending moment at least 21 kN/m in the zone below the rail and at least 13 kN/m in the centre zone. At the said pressure, the cracks that can be seen shall be with length not more than 25 mm and with width at the crack base not exceeding 0.05 mm.
- xiii. Pre-stressing steel shall be in accordance with ENV 10138:1994. It shall provide enough reliability of the loading capacity of the cross section of the sleeper through such a quantity of threads and distributed throughout the cross section in such a way to evenly and gradually accept the released pre-tension.
- xiv. Each sleeper shall be embossed with sleeper type, the manufacturer's mark, month and year of production.
- xv. Concrete sleeper shall be used not earlier than 28 days from the date of its production.

7.6.5.3 Tests and Acceptance

- i. The representative(s) of the Employer/Engineer shall be entitled to observe, by day or night, the method of manufacture and to be present at all tests relating to all casts for his railway and to examine the results obtained from such tests.
- ii. The representative(s) of the Employer/Engineer shall be entitled to carry out all necessary checks at the manufacturer's premises to ensure that the manufacture is strictly in accordance with the stipulated conditions.
- iii. The supervision shall be conducted in such a way that it does not interfere with the normal manufacturing operations without valid reasons.
- iv. All travel, accommodation (including meals) for the presence of up to three (3) representatives of the Employer/Engineer to the manufacturer's premises shall be at the expense of the Contractor.
- v. The Contractor shall be bound to inform and invite the Employer/Engineer for acceptance at least 30 days in advance of the date anticipated for the beginning of the rolling schedule.

7.7 ELASTIC FASTENING SYSTEM

7.7.1 General Requirements

- i. Rail fastenings shall comply with EN 13146 and EN 13481.
- ii. Elastic rail fastening system shall be of direct type without baseplate, simple to install, capable of easy visual inspection. The resilient/elastic rail track fastening must be suitable for the following basic design characteristics:
 - a) rail R-65;
 - b) axle load 25 tonnes (250 kN) /axle;
 - c) speed 160 km/hr;
 - d) minimum radius 190 m maximum gradient 35‰;
 - e) rail inclination 1:40 (rail inclination to be facilitated with the concrete sleeper rail seat);
- iii. They are required to be used with concrete sleepers for rails R-65 equipped with a modern interlocking and a signal system.
- iv. The system shall also be able to be completely pre-assembled in the sleeper factory for allowing best accuracy and full degree of automation of track laying. Assembling in track shall be executed by moving the spring clip from preassembling position onto the rail without any rotation of clip.
- v. If the fastening contains screws, they shall be anchored in replaceable plastic dowels with drainage hole on bottom side of the concrete sleeper.
- vi. The anchoring devices shall not be subjected to any lateral force.
- vii. The rail fastening system shall have a protection against tilting/rotation of rails and overstressing of its spring elements (two elasticities). The maximum increase of gauge shall not exceed 6 mm under effect of repeated loading tests at room temperature.
- viii. The fastening system must be electrically insulated without any additional insulating parts. The fastening system must ensure 2.5 Ohms/km track insulation and not less than 10000 Ohms between the two rail seats of one sleeper. Insulating materials (elastic sub-sleeper joists plastic elements or other insulating elements of the fastening) shall provide an electric insulating resistance not less than 2.106 Ω at a voltage of 2 500 V. Refer to EN 50122-2 for compliance requirements.
- ix. After a vertical loading of one tension clamp with 25 kN and after a release of 4 mm a test load of min. 5.5 kN shall remain.
- x. Lateral adjustment of ± 5 mm on each rail must be possible, preferred in steps of 1.0 mm.
- xi. Dynamic requirements of each spring element in final assembly position: min 5 million load cycles with an oscillation amplitude of min 1.8 mm.
- xii. Only one type of fastening is to be provided for the whole of the Works.

7.7.2 Quality of Materials

Material quality compliance with the applicable UIC & DIN standards for the elastic fastening system shall be confirmed at the time of tender.

7.7.3 Spring Clips

- i. The material shall be an alloy spring steel according to DIN 17221 or equivalent, free from surface and internal defects.
- ii. The clips shall be heat-treated to achieve a surface hardness in the range 400 - 460 Vickers 30.
- iii. The elastic clips mounted on rail must achieve a clamping force of 2×10 kN = 20 kN per rail seat at a spring deflection of not less than 12 mm.

- iv. Longitudinal resistance of rail for one fastening set must be at least ≥ 7 kN, but 9 kN is recommended, for the installation of CWR.
- v. Clips shall be supplied free of burrs which may be considered harmful when handled or affect efficient assembly of the clip.
- vi. Clips shall be provided with sherardized coating or equivalent anti-corrosive protection.

7.7.4 Rail insulators/Angled Guide Plates

- i. The material shall be made of glass reinforced synthetic material with about 30 % of glass fibre reinforcement, and resistance to ultraviolet radiation or equivalent material with the same physical properties. They are required to be used with elastic fastenings, concrete sleepers for rails sleepers for rails R-65 equipped with modern interlocking and signalling system.
- ii. Materials shall be tested in accordance with the requirements of DIN 53453 or equivalent.

7.7.5 Rail Pads

- i. Rail pads shall be made in compliance with UIC Leaflet 864-5.
- ii. The surfaces in contact with the rail and the sleeper maybe either plain and smooth or configured in some way.

7.7.6 Sleeper Screws (if required)

- i. Sleeper screws shall be made of material according to UIC864-1, newest edition and/or ISO 898-1 or equivalent.
- ii. All sleeper screws shall be sherardized or hot dip galvanised.
- iii. If the fastening system contains screws, they shall be made of steel with parameters as follows:
 - (a) Unhardened
 - (b) Tensile strength: min 400 n/mm²
 - (c) Elongation at breakage: min 22%
 - (d) Yield point: min 240 N/mm²
- iv. Dimensions shall be in accordance to drawings offered by the supplier of the complete rail fastening system.

7.7.7 Quality Assurance of the Fastening System

Tests will be executed according to requirements of the Employer and/or national standards in the country of the fastening system manufacturer. Technical Requirements of the Employer and/or fastening system manufacturer's national railway organisation and fastening system manufacturer's quality control plan.

7.7.8 Warranty of the Fastening System

Warranty period shall be in accordance with UIC standards or equivalent for each of the offered elements.

7.7.9 Tests and Acceptance of the Fastening System

- i. The representative(s) of the Employer/Engineer shall be entitled to observe, by day or night, the method of manufacture and to be present at all tests relating to all fastening system for his railway and to examine the results obtained from such tests.

- ii. The Employer/Engineer shall be entitled to carry out all necessary checks at the manufacturer's premises to ensure that the manufacture is strictly in accordance with the stipulated conditions.
- iii. The supervision shall be conducted in such a way that it does not interfere with the normal manufacturing operations without valid reasons.
- iv. All travel, accommodation (with meals) and the presence of up to three (3) representatives of the Employer/Engineer to the fastening systems manufacturers shall be at the expense of the Contractor.
- v. The successful Tenderer shall be bound to inform and invite the Employer/Engineer for acceptance at least 30 days in advance of the date anticipated for the beginning of the manufacturing schedule.

7.8 Turnout R-65 Type 1:11 – Technical Requirements

7.8.1 General Requirements

- i. For the main lines new turnouts type R-65, 1/11; R300 shall be used in compliance with EN 13232 or equivalent GOST standard.
- ii. The manufacturer of the turnouts shall possess a quality certificate ISO 9001.
- iii. On sidings included in the scope of the Contract for construction and/or reconstruction, refurbished second-hand turnouts type R-65, 1/11; R300 may be used, provided they strictly comply with ADY's regulations.
- iv. The turnout parameters shall be as follows:

(a) Gauge:	1520 mm.
(b) Rail profile:	R-65 – 64.88 kg/m quality R350 HT (R260 for refurbished turnouts)
(c) Speed on the straight track:	140 km/hr (design speed 154 km/hr)
(d) Speed on the diverted track:	50 km/hr
(e) Axle load:	25 tonnes/axle load (250 kN).
(f) Annual load:	> 20 Million gross tonnes.
(g) Core type:	Motionless Core.
(h) Switch rail type:	Spring switch rail.
(i) Sleepers:	Pre-stressed Reinforced Concrete Bearers Hardwood Timber/Wood Bearers for Refurbished turnouts
(j) Rail Inclination:	Rail inclination of 1:40 shall be facilitated throughout the turnout with inclined base plate
(k) Fastenings:	Elastic fastening on base plates.
(l) CWR:	Turnout design shall allow for use in CWR

7.8.2 Switches

- i. Switch rail profile shall be Zu 1-60 - 73,00 kg/m, 60 D40 - 70 kg/m - head inclined 1:40 or similar.
- ii. The switch rail profile shall be forged into a standard rail profile at the end.
- iii. The profile of the stock rail shall be standard and tilled at the sight of the switch rail. Basic material of switch and stock rail shall be R350HT.
- iv. Lubrication-free switch rollers shall be installed.
- v. A system shall be designed to prevent the higher deviations of the switch.
- vi. A system shall be designed to ensure the certain location of the sleeper in the locking area.

- vii. The least possible distance between the opened switch rail and the stock rail shall be 60 mm
- viii. The locking area shall not be affected by temperature changes without adjustment for seasonal changes in temperature.

7.8.3 Intermediate Section

- i. The intermediate rails shall be of steel R350 HT Grade.
- ii. The fastening system shall be in accordance with technical specification for fastenings.

7.8.4 Frog

- i. The frog shall be fully cast single piece Manganese 13 with peak of the core Mn 13 in accordance with UIC 866. Running surfaces shall be explosive hardened to at least 320HB (or Monoblock cast manganese steel /Mn13/, explosively hardened to at least 320 HB, with shop flash-butt welded R-65 rail ends (R350HT) and the running areas machined to 1:40) .
- ii. Check-rail shall be adjustable type with profile UIC 33- 32.90 kg/m; quality - 1100 under UIC 860.
- iii. The check-rail shall be mounted on bearings and shall be 20 mm higher than the head of the rail. The main width shall be constructed so that to be regulated with laminated plates.
- iv. Jointing the check-rail shall be executed with a high tensile M22 bolt with a double spring-washer.

7.8.5 Elastic Fastening according to the specification of fastenings

- i. Fixing the rails and check-rails, as well as the constructive elements and sleepers shall be performed by ribbed baseplate, 160 mm by width and 20mm thick according to UIC 864-7.
- ii. Stock-rails shall be fixed with elastic connections in their inner side and these joints shall pass through the slider of the switch rail.
- iii. Ribbed cushions if required shall be produced of stretch material, pressed or cast of welded steel or welded details.
- iv. An anti-creep device shall be built into the turnout so as to permit the turnout to be installed in CWR track.

7.8.6 Reinforced Concrete Turnout Bearers

- i. The form of bearers in the section of the switch rail arc shall be fan-shaped, in the section of straight frogs - semi-angled.
- ii. The distance between the bearers shall be 600 ± 25 mm. Sleepers shall have a cross-section 282/300 mm by width and to a height of 220mm.
- iii. The length shall be conforming to the fact that the distance between the construction edge of the rail and the end of the bearer shall be around 580 mm or less, if the bending moment of the bearers is not weakened.
- iv. The inclination of rails in the main track, station tracks and in the new turnouts shall be continuously 1:40.

7.8.7 Drive and Locking Device, Point Machine and Motor

- i. Each turnout (new and refurbished) shall be supplied with a motorised Point Machine electrically operated, with a 160V DC electric motor so that the integration of the point machines into the existing signalling system will require no changes to the signalling system configuration.

- ii. Additionally each supplied Point Machine shall have supplied a 3-phase 230/400 V AC electric motor that can be directly interchanged with the DC motor to accommodate a future signalling upgrade.
- iii. Point machines shall comply with UIC 734: 2ED 2004, certified to ISO 14001:2015 and IP67 protection compliant.
- iv. The drive, switch locking device including all rodding, sole plate and other switch operating devices shall be supplied by the Contractor, and suitable for 160km/hr train speeds.
- v. To ensure the proper operation of existing track circuits located on the turnouts, each rail should be isolated, where isolation points should be:
 - a. On both sides of the switch (tongue) rail connections to the stretcher bar
 - b. All rail connections of point machines

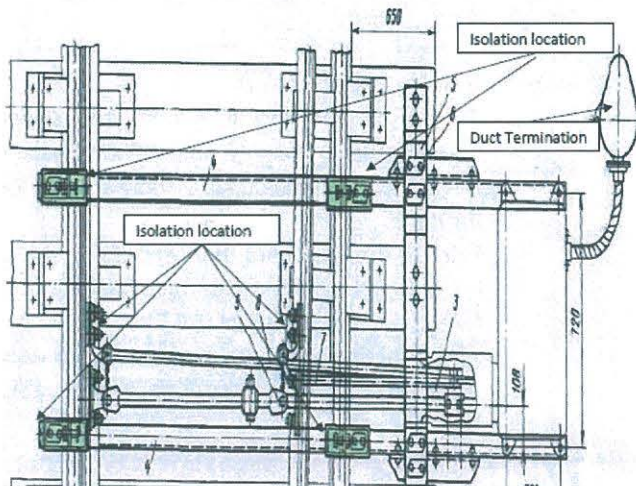
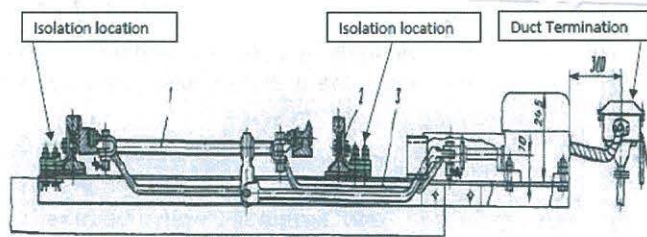

- vi. The switch rail position detection shall be included in the Point Machine, with the final position of the switch rail monitored by tongue shift testers. Existing point machines have contact-type mechanism. New point machines should have similar operating principles and similar scheme to ensure adaptation with the existing signalling system.
- vii. Inner configuration of the new point machines should be compatible with the existing cabling system. Existing point machine is operating 2 or 4 wire control scheme. Inner configuration of the existing point machines are given below;

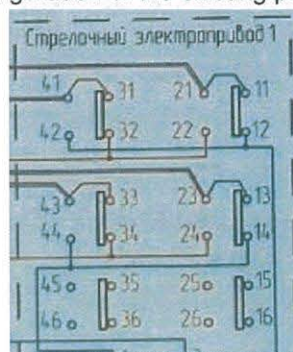

- viii. Switch locking shall be at 2mm clearance or less. If the clearance is larger than 2mm the locking device shall be designed so as not to lock the switch.
- ix. The switch-over time of the Point Machine shall not be more than six (6) seconds.
- x. Manual operation of the Point Machine shall be possible, and all necessary tools for each Point Machine shall be provided for manual operation.
- xi. When the Point Machine lever is inserted for manual operation, electric power to the motor will be automatically disconnected, with an indication sent to the control centre and station as sequence flashing for two positions of the switch.
- xii. The Point Machine shall be readily adapted to any network or interlocking, and suitable for both left and right hand turnouts.
- xiii. The Point Machine shall be in a rugged metal box with metal cover, be vandal-proof.
- xiv. Point Machine shall have internal type locking mechanism.
- xv. The requirement of trailable or non-trailable Point Machines will be decided during the design stage.
- xvi. Connection to power supply and signalling cables from the point machine will be to the underground duct that terminates near the point machine. Additional ducting, and termination pit if required, from the point machine to the duct termination point to permit this connection shall be designed and installed by the Contractor.

7.8.8 Additional Requirement - Turnouts

- i. The Contractor shall submit for approval a Method Statement for the manufacturing, supply, installation and commissioning of the turnouts, which shall include detailed procedures for transport, handling, lifting, storage of the turnouts,
- ii. Prior to the supply of the turnouts to site at least one turnout of each type must be completely pre-assembled including point machine and locking device for factory acceptance test (FAT).
- iii. After installation of the first turnout of each type a joint site inspection shall be undertaken to verify proper handling, installation and functionality of the turnouts.

7.9 Turnout R-65 Type 1:9 - Technical Requirements

7.9.1 General Requirements

- i. For the main line and sidings, which are not the main tracks, and which are used for arrival/departure of trains new turnouts type R-65, 1/9; R300 may be used in compliance with EN 13232 or equivalent GOST standard.
- ii. On the other sidings included in the scope of the Contract for construction and/or reconstruction, refurbished second-hand turnouts type R-65, R/11 or 1:9; R300 may be used, provided they strictly comply with ADY's regulations.
- iii. Where it is required to adjust siding tracks to align with the installed refurbished contracts, this shall be included within the Contractors scope.
- iv. The turnout parameters shall be as follows:

(a) Gauge:	1520 mm.
(b) Rail profile:	R-65 – 64.88 kg/m quality R350 HT (R260 for refurbished turnouts)
(c) Speed on the straight track:	140 km/hr (design speed 154 km/hr)
(d) Speed on the diverted track:	40 km/hr.
(e) Axle load:	25 tonnes/axle load (250 kN).
(f) Annual load:	> 20 Million tonnes.

(g) Core type:	Motionless Core.
(h) Switch rail type:	Spring switch rail.
(i) Sleepers:	Pre-stressed Reinforced Concrete Bearers Hardwood Timber/Wood Bearers for Refurbished turnouts
(j) Rail Inclination:	Rail inclination of 1:40 shall be facilitated throughout the new turnouts with inclined base plates.
(k) Fastenings:	Elastic fastening on base plates.
(l) CWR:	New turnout design shall allow for CWR

7.9.2 Switches (for new turnouts)

- i. Switch rail profile shall be Zu 1-60 - 73,00 kg/m, 60 D40 - 70 kg/m - head inclined 1:40 or similar.
- ii. The switch rail profile shall be forged into a standard rail profile at the end.
- iii. The profile of the stock rail shall be standard and tilled at the sight of the switch rail. Basic material of switch and stock rail shall be R350HT.
- iv. Lubrication-free switch rollers shall be installed.
- v. A system shall be designed to prevent the higher deviations of the switch.
- vi. A system shall be designed to ensure the certain location of the sleeper in the locking area.
- vii. The least possible distance between the opened switch rail and the stock rail shall be 60 mm
- viii. The locking area shall not be affected by temperature changes without adjustment for seasonal changes in temperature.

7.9.3 Intermediate Section (for new turnouts)

- i. The intermediate rails shall be of steel R350 HT Grade.
- ii. The fastening system shall be in accordance with technical specification for fastenings.

7.9.4 Frog (for new turnouts)

- i. The frog shall be fully cast single piece Manganese 13 with peak of the core Mn 13 in accordance with UIC 866. Running surfaces shall be explosive hardened to at least 320HB (or Monoblock cast manganese steel /Mn13/, explosively hardened to at least 320 HB, with shop flash-butt welded R-65 rail ends (R350HT) and the running areas machined to 1:40).
- ii. Check-rail shall be adjustable type with profile UIC 33- 32.90 kg/m; quality - 1100 under UIC 860.
- iii. The check-rail shall be mounted on bearings and shall be 20 mm higher than the head of the rail. The main width shall be constructed so that to be regulated with laminated plates.
- iv. Jointing the check-rail shall be executed with a high tensile M22 bolt with a double spring-washer.

7.9.5 Fastenings (for new turnouts)

- i. Fixing the rails and check-rails, as well as the constructive elements and sleepers shall be performed by ribbed baseplate, 160 mm by width and 20mm thick according to UIC 864-7.
- ii. Stock-rails shall be fixed with elastic connections in their inner side and these joints shall pass through the slider of the switch rail.

- iii. Ribbed cushions if required shall be produced of stretch material, pressed or cast of welded steel or welded details.
- iv. An anti-creep device shall be built into the turnout so as to permit the turnout to be installed in CWR track.

7.9.6 Reinforced Concrete Bearers (for new turnouts)

- i. The form of bearers in the section of the switch rail arc shall be fan-shaped, in the section of straight frogs - semi-angled.
- ii. The distance between the bearers shall be 600 ± 25 mm and shall be cross-sectioned, 282/300 mm by width and to a height of 220 mm.
- iii. The length of the bearers shall be such that the distance between the construction edge of the rail and the end of the bearer shall be 580 mm or more, as long as the bending moment of the bearers is not weakened.
- iv. The inclination of rails in the main track, station tracks and in the new turnouts shall be continuously 1:40.

7.9.7 Drive and Locking Device, Point Machine and Motor

7.9.8 Drive and Locking Device, Point Machine and Motor

- i. Each turnout (new and refurbished) shall be supplied with a motorised Point Machine electrically operated, with a 160V DC electric motor so that the integration of the point machines into the existing signalling system will require no changes to the signalling system configuration.
- ii. Additionally each supplied Point Machine shall have supplied a 3-phase 230/400 V AC electric motor that can be directly interchanged with the DC motor to accommodate a future signalling upgrade.
- iii. Point machines shall comply with UIC 734: 2ED 2004, certified to ISO 14001:2015 and IP67 protection compliant.
- iv. The drive, switch locking device including all rodding, sole plate and other switch operating devices shall be supplied by the Contractor, and suitable for 160km/hr train speeds.
- v. To ensure the proper operation of existing track circuits located on the turnouts, each rail should be isolated, where isolation points should be:
 - a) On both sides of the switch (tongue) rail connections to the stretcher bar
 - b) All rail connections of point machines

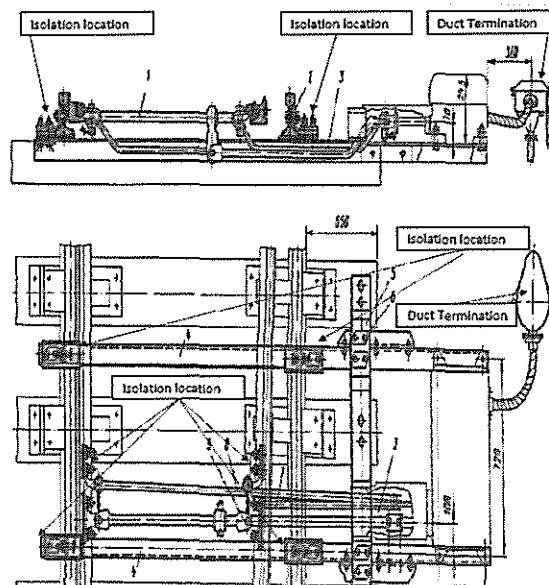

- vi. The switch rail position detection shall be included in the Point Machine, with the final position of the switch rail monitored by tongue shift testers. Existing point machines have contact-type mechanism. New point machines should have similar operating principles and similar scheme to ensure adaptation with the existing signalling system.
- vii. Inner configuration of the new point machines should be compatible with the existing cabling system. Existing point machine is operating 2 or 4 wire control scheme. Inner configuration of the existing point machines are given below;



- viii. Switch locking shall be at 2mm clearance or less. If the clearance is larger than 2mm the locking device shall be designed so as not to lock the switch.
- ix. The switch-over time of the Point Machine shall not be more than six (6) seconds.
- x. Manual operation of the Point Machine shall be possible, and all necessary tools for each Point Machine shall be provided for manual operation.
- xi. When the Point Machine lever is inserted for manual operation, electric power to the motor will be automatically disconnected, with an indication sent to the control centre and station as sequence flashing for two positions of the switch.
- xii. The Point Machine shall be readily adapted to any network or interlocking, and suitable for both left and right hand turnouts.
- xiii. The Point Machine shall be in a rugged metal box with metal cover, be vandal-proof.
- xiv. Point Machine shall have internal type locking mechanism.
- xv. The requirement of trailable or non-trailable Point Machines will be decided during the design stage.
- xvi. Connection to power supply and signalling cables from the point machine will be to the underground duct that terminates near the point machine. Additional ducting, and termination pit if required, from the point machine to the duct termination point to permit this connection shall be designed and installed by the Contractor.

7.10 BALLAST

- i. Ballast with sieve size 63/22.4 shall be used in accordance with the Azerbaijan National Standard and AzDTN/GOST, SNIP, including EN 13450 +AC "Crushed Stone for Railway Lines".
- ii. Ballast shall be washed to remove excess fines before placement into the track.
- iii. Limestone ballast shall not be used. Limestone may be used for protection/anti-frost layer in accordance with ADY regulations
- iv. Requirements about quarries:
 - a) The Contractor may supply the ballast from any local or foreign quarry.
 - b) The quality of the ballast to be supplied shall be consulted with the Employer, prior to the final approval by the Engineer;
 - c) The Contractor shall not be allowed to use ballast from different quarries on one and the same track section;
 - d) For planning the ballast quantities/distribution a track section shall be the distance of the line (no matter single or double) with a minimum length of 5 km and may include turnouts on the main track.
 - e) The start/end of every such section shall be at least 50 m away from any turnout or track structure and the exact locations of these sections shall be approved by the Engineer and included in the as-built drawings.

8 TRACK DISMANTLING & SUB-STRUCTURE CONSTRUCTION

The track includes the running rails, fastening system, sleepers and all attachments to the rails, as well as the turnouts with fastenings, turnout bearers, point machines and drive component and other equipment supporting the signaling system that is part of the track.

The sub-structure of the railway shall include all layers situated under the track and including the embankment, which is referenced here as the sub-grade. Thus the sub-structure includes the sub-grade (embankment), sub-ballast and all its components.

8.1 Track Sub-Structure

The Track Sub-structure generally consists of following layers (Refer **Appendix 1**)

- a) Sub-ballast
- b) Sub-grade

- 8.1.1 To maintain the same Top of Rail (ToR), the designed ToR shall be the same as the existing designed ToR.
- 8.1.2 After the track has been removed by the Contractor, the tracks 1 & 2 (i.e. the main line tracks) shall be excavated to a depth of at least 1050 mm (with tolerance minus 12mm plus 50mm) from the designed ToR and for a width of typically 3100 mm from the centre line of track to the field side(s) of the track. Where ballast and/or sub-ballast extends past 3100mm, the whole area shall be cleared. Any item, e.g. post, sign, kilometre post etc. located in the 3100mm region shall be removed (except the OCS poles and footings shall remain). Those items removed shall be replaced after the works are completed, unless instructed by the Engineer to omit certain items.
- 8.1.3 After the track has been removed by the Contractor, the tracks 3 & 4 (i.e. the side tracks at stations) shall be excavated to a depth of at least 1050 mm (with tolerance minus 12mm plus 50mm) from the designed ToR and for a width of typically 3100 mm from the centre line of track to the field side(s) of the track or up to the fixed platform structure adjacent to the track. Where ballast and/or sub-ballast extends past 3100mm, the whole area shall be cleared. Any item, e.g. post, sign, kilometre post etc. located in the 3100mm region shall be removed (except the OCS poles and footings shall remain). Those items removed shall be replaced after the works are completed, unless instructed by the Engineer to omit certain items.
- 8.1.4 For the whole area between multiple tracks, where multiple tracks are two or more tracks, the entire area between the tracks shall be excavated to 1050mm (-12mm +50mm) below designed ToR. In stations the excavation shall be complete between platform step edges. This will remove any existing ballast and sub-ballast that was below all sleepers.
- 8.1.5 Once excavated to 1050mm (-12mm +50mm) below designed ToR, the sub-grade shall be rolled and shaped to provide the necessary 5% gradient (slope) for drainage. The sub-grade shall then be dynamic plate tested for the required deformation modulus.
- 8.1.6 Minimum required deformation modulus E_g for sub-grade layers and the deformation modulus E_o for sub-ballast layer and are shown in Table 8 below.
- 8.1.7 Testing for the deformation modulus (E_o and E_g) on-site shall be undertaken by the dynamic plate load test e.g. light falling weight deflectometer, light drop weight tester, light weight deflectometer or similar approved system.
- 8.1.8 The deformation modulus is measured and reported in MPa, i.e. N/mm²

TABLE 8 – TRACK SUB-STRUCTURE REQUIREMENTS

REHABILITATED RAILWAY	Sub-Grade Minimum MPa (E_g)	Sub-Ballast		Ballast Minimum Thickness (mm) under bottom of sleeper
		Minimum MPa (E_o)	Minimum Thickness (mm)	
Main Lines with max. speed \leq 160 km/hr	30	50	300	350
Side Tracks No 3 & 4 in Stations	20	40	300	350

8.1.8.1 The E_g and E_o values are the deformation modulus as defined in EN 16907-1-2016 and measured by a dynamic plate load test according to ASTM E 2835-11 or TP BF-StB Part B8.3.

8.1.8.2 The testing requirements for deformation modulus measurements shall be:

- Main line (Tracks 1 & 2) Every 50 metres along the track
- Side tracks Every 50 metres along the track
- Level Crossings Each end along the track and in the centre
- Animal Crossings Each end along the track
- Turnouts Each end along the track and intermediate at equal intervals not exceeding 10 metres

8.1.9 The excavated material can be set aside for re-use by re-blending (if not contaminated with hydrocarbons or other chemicals exceeding the MENR requirements), or disposed of in locations off-site or on-site as agreed with the Engineer.

8.1.10 Once the sub-grade is shaped and compacted and passed the compaction testing, then sub-ballast can be placed to a thickness of 300mm, shaped as required with a 5% gradient for drainage, compacted and tested for the required deformation modulus.

8.1.11 Any track drainage that is required to be located within the sub-grade or sub-ballast shall then be installed. In particular any sub-surface drains shall be installed with minimal disturbance to the sub-grade and sub-ballast compaction. Any disturbance will require the affected area to be further compacted.

8.1.12 During track removal and sub-structure construction care shall be taken to minimise any disturbance to the signalling system (cables, impedance bonds, signal poles etc.) and the overhead catenary system (OCS poles, traction return cables etc.). Any disturbance shall be made good, and any damage shall be immediately reported to the Engineer and ADY maintenance personnel so the damage can be corrected. The Contractor shall be responsible for all costs (labour and materials) associated with the repair of damages to signalling and/or OCS equipment.

8.2 Problematic Locations for Excavation Testing & Reconstruction

8.2.1 After excavation for the required 1050mm (+50mm -25mm tolerance) from Top of Rail, the sub-grade value shall be tested to confirm suitability. If dynamic plate load testing confirms the minimum required deformation modulus E_g 30 MPa on main lines and E_g 20 MPa for the side tracks 3 & 4, then the sub-grade shall be shaped to achieve the 5% camber/crossfall required for drainage. If the sub-grade is wet (due to high water table) then Geotextile and Geo-grid can be placed on the sub-grade if instructed by the Engineer prior to sub-ballast placement. Sub-ballast shall then be placed and compacted to the required 300mm thickness and then tested to confirm an E_o value of 50MPa for main lines and 40MPa for the side tracks 3 & 4 in stations. If the values are not achieved the sub-ballast shall be further worked until the required E_o value is achieved.

8.2.2 If after excavation of the 1050mm is completed and testing shows the sub-grade to be less than the required deformation modulus E_g 30 MPa for main lines and E_g 20 MPa for the side tracks 3 & 4, then the Contractor shall excavate for a further 200mm to 1250mm from ToR, compact the sub-grade and further test the surface.

If the required E_g value of the sub-grade is less than E_g 30Mpa then one layer of geo-grid shall be firstly placed on the cambered/crossfall surface of sub-grade and followed by one layer of type 500 geotextile (see **Appendix 1** for details) placed on the geo-grid. On the geo-grid & geotextile sub-ballast material shall be laid and compacted for a depth of 100mm.

Another layer of geo-grid shall then be placed on the compacted surface and a further 100mm of sub-ballast material shall be laid, graded and compacted to achieve the required E_g value.

Sub-ballast shall then be placed to the required 300mm thickness and shaped to achieve the 5% camber/crossfall required for drainage.

The compacted sub-ballast is then tested to confirm an E_o value of 50MPa for main lines and 40MPa for the side tracks 3 & 4 in stations. If the values are not achieved the sub-ballast shall be further worked until the required E_o value is achieved. Additional geo-grid can be installed within the sub-ballast to aid in the achievement of the required deformation modulus, with the pre-approval of the Engineer.

After placement of the sub-ballast, any drainage that is required below the track shall be installed, and the sub-ballast shape and compaction made good to the relevant compaction standards.

Once the Engineer is satisfied that the sub-ballast (and any drainage installed) is satisfactory and meets the deformation modulus requirements only then can bottom ballast (to the underside of the sleepers) be installed.

Refer to Drawings in **Appendix 1** for details.

8.3 Contaminated Areas for Excavation & Reconstruction

8.3.1 At some of the nine (9) Stations in Lot 1, there is a quantity of concentrated contamination on the track in locations where locomotives stop and wait. These locations are shown on the sketch below. There may be other locations as identified by the Engineer.

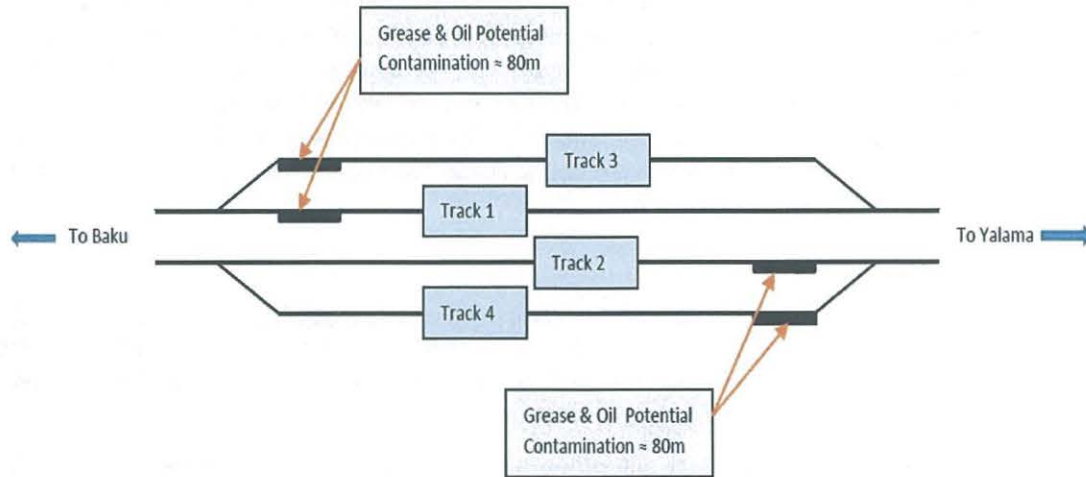

Potential Contaminated Areas at Stations

8.3.2 Prior to the excavation for the required 1050mm (+50mm -25mm tolerance) from Top of Rail, the surface contamination of oil and grease needs to be removed and disposed of in a suitable area approved by the Engineer.

8.3.3 At the contaminated areas the following actions are required to be carried out by the Contractor:

- i. Identify the contaminated areas and determine its length and width. Agree this quantity with the Engineer
- ii. Dismantle the track in the agreed contaminated area by removing the track components: rail, fastening and sleepers.
- iii. Store the dismantled track components in a bunded location where these can be cleaned (Note: A bunded location is required so that no contaminants will disperse when cleaning is undertaken)
- iv. Clean all contaminants from the track components and then place the components into the ADY storage as designated (see Part 4: Dismantled Materials for details on storage of dismantled material)
- v. Completely clean the bunded area to the satisfaction of the Engineer, collect the contaminated material and place with the excavated contaminated material.
- vi. With the track removed, then excavate the contamination material for a complete depth of contamination and width about the centreline of the track. This excavated material is regarded as "contaminated material".
- vii. Confirm with the Engineer that all contaminated material has been removed.
- viii. Dispose of the contaminated material in a location as designated and approved by MENR and by the Employer/Engineer.

8.4 TRACK CONSTRUCTION – MAIN LINES (TRACKS 1 & 2)

- 8.4.1** Track construction shall be defined by the Contractor in method statements and submitted to the Engineer for agreement.
- 8.4.2** Track construction shall be planned to follow these following broad requirements and shall be detailed in the Contractor's method statements:
- i. Bottom ballast i.e. the ballast beneath the sleeper, shall be 350mm minimum;
 - ii. The initial layer of bottom ballast shall be laid at a thickness between 200 and 250mm and then compacted using vibrating rollers and/or vibrating plates;
 - iii. Sleepers shall be placed on the compacted first layer of bottom ballast and spaced correctly;
 - iv. R-65 Rail of the correct grade shall then be run and placed on the sleepers and loosely fastened;
 - v. Top ballast shall then be placed on the track, fastenings tightened and the track tamped using a heavy on-track tamping machine, and ballast regulated by an on-track ballast regulator;
 - vi. At least three passes of tamping and ballasting will be required to bring the track up to final line and design level;
 - vii. Dynamic track stabilisers shall be used to compact the track followed by tamping and regulating;
 - viii. Track welding, glued insulated joint installation, and destressing shall then follow as per a separate detailed method statement.
 - ix. Further tamping by a heavy on-track tamping machine, and ballast regulated by an on-track ballast regulator may be required after welding and destressing.
- 8.4.3** During track construction care shall be taken to minimise any disturbance to the signalling system (cables, impedance bonds, signal poles etc.) and the overhead catenary system (OCS poles, traction return cables etc.). Any disturbance shall be made good, and any damage shall be immediately reported to the Engineer and ADY maintenance personnel so the damage can be corrected. The Contractor shall be responsible for all costs associated with the repair of damages to signalling and/or OCS equipment.

8.5 TRACK CONSTRUCTION – TRACKS 3 & 4

- 8.5.1** The track work for Tracks 3 & 4 in stations shall be constructed as set out in 8.4 above, with the exception that the tracks shall not have continuously welded rail (CWR) but long welded rail (LWR) of 300m or more, depending on design requirements. Rail shall be selected used rail, with selection based on lowest wear and lowest defect rail being selected.
- 8.5.2** Joints between LWR shall be mechanical joints using 6 hole fishplates (6 holes per rail).
- 8.5.3** Turnouts installed on Tracks 3 & 4 shall be refurbished (non-welded type).
- 8.5.4** Any signalling system installed on Tracks 3 & 4 shall be reinstated to its original condition.

8.1 TRACK CONSTRUCTION – TURNOUTS

- 8.1.1** All turnouts shall be pre-assembled before installation, checked for quality, dimensions and tolerances and approved by the Engineer before installation into the track.
- 8.1.2** Refurbished turnouts shall be pre-assembled adjacent to the location to be installed, or if that is not practical, at a location agreed with the Engineer

9 LINESIDE & CROSS TRACK DRAINAGE SYSTEM

9.1 HYDROLOGICAL STUDY AND DRAINAGE DESIGN

The Contractor shall undertake a Hydrological Study to determine waterway openings and drainage requirements along all of Lot 1. The Study findings shall be used in the design for sizing existing structures requiring renewal, other structures as required and determining and designing surface drainage requirements.

Note that the sizing of waterways, pipes and culverts in the Attachments to the Employer's Requirements are recommendations only and their sizing shall be determined (or confirmed) by design using data derived from the Hydrological Study.

The purpose of the drainage system is to prevent flooding, collapse of embankments, weakening of infrastructure, and as a result – deflection, cracks, run-off, and maintenance problems. The drainage design constitutes an integral part of the railway track and requires careful design.

As such, standards to ensure that waterways are fit for purpose, constructed, monitored and maintained to provide clear and unobstructed flow of storm water under all normal conditions are set out in this Specification.

The Contractor shall design, supply, install and construct all lineside, longitudinal and cross track (transverse) storm water drainage system according to the requirements set out in this Specification so as to provide a railway drainage system that will have a life of at least 50 years.

9.2 GENERAL – STORM WATER & CATCHMENT DRAINAGE

The Storm Water and Catchment Drainage shall include:

- a) Culverts to drain runoff from catchments from one side of the railway embankment to the other along the length of the alignment;
- b) Sub-surface drainage systems, French drains, pipes and pits;
- c) Gullies, inlets, pipework, manholes;
- d) Open channels and spill ways;
- e) Attenuation and evaporation ponds;
- f) Pumping stations and soakaways;
- g) Sub-soil;
- h) Suitable discharge points / outfalls

9.3 MANDATORY STANDARDS AND/OR DIRECTIVES

The UIC Leaflet 719R guidelines, standards and regulatory documents shall be used for all design and construction related Works for Drainage.

9.4 DRAINAGE FUNCTIONAL REQUIREMENTS

- 9.4.1** The Contractor shall design, construct, and handover drainage as per the requirements of this specification and the local drainage authority/Municipality Standard Specification relating to Storm Water Drainage System.
- 9.4.2** This liaison and co-ordination for a future drainage connection from the external network shall be undertaken by the Contractor. The capacity of the external network shall require review and confirmation by the relevant Authority.
- 9.4.3** The Contractor is responsible to ensure that an appropriate drainage system is in place that will minimise operations and maintenance requirements including treatment facilities and contaminant runoff.
- 9.4.4** A range of storm events representing varying rainfall duration shall be investigated. The drainage design shall be carried out adopting the critical rainfall event.
- 9.4.5** All bridge openings, shall be designed for 1 in 100 year Average Recurrence Interval (ARI) flow, and adjusted to take into account predicted climate change developments. The catchment areas required for peak flow rate calculations shall be determined using (in order of preference) site survey, site measurements or suitably scaled topographic maps. Account shall be taken of water flowing onto the rail corridor from adjoining properties and streets.
- 9.4.6** All track and non-track drainage structures, culvert and pipe structures shall be designed for 1 in 50 year Average Recurrence Interval (ARI) flow.
- 9.4.7** The Contractor shall demonstrate in the design that the drainage systems are capable of carrying the flows required for the relevant ARI. The design shall demonstrate that the selection of materials and sizing of pipes and flow rates are not excessive for the type of drainage system designed and will not cause erosion, silting up or shortened life of any of the selected drainage types and systems designed.
- 9.4.8** When selecting a pipe, the environmental conditions shall be considered (i.e. is the water abrasive, acidic or alkaline) and the manufacturer's specifications consulted regarding the pipe's suitability to the predicted environment.
- 9.4.9** The possible effects of non-standard ballast profiles shall be considered.
- 9.4.10** Geometric effects of laying straight longitudinal pipes adjacent to the track around curves shall be considered including reduction in sump spacing to maintain pipe clearance from track.
- 9.4.11** The permanent effects of the drainage system located alongside existing structures such as OCS support poles, signal masts and gantries, retaining walls, platforms embankments, shall be taken into account.
- 9.4.12** The design must also highlight and account for the possibility of causing instability of an existing structure during the excavation stage.
- 9.4.13** Conflict with existing services shall be considered. Service searches shall be conducted and the locations of these services included in the design.

- 9.4.14 Cess drains are located at formation level at the side of the track. The flow capacity of the open channel cess drain shall be greater than the peak flow rate calculated for the section of track.
- 9.4.15 For ease of maintenance, over-sized channels can be adopted to allow a certain degree of sediment build up to occur and still work effectively.

Figure 9.3 – Open Channel Types (Type 1 & Type 2)

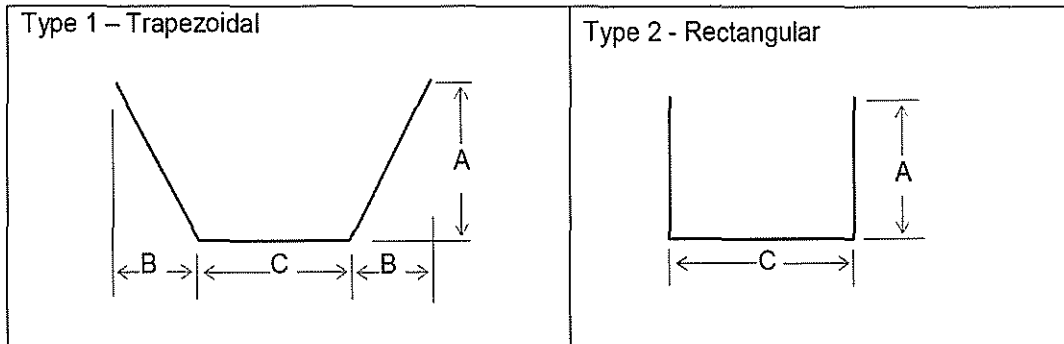

- Note: The minimum dimensions of a trapezoidal open channel or rectangular open channel shall be: A= 200, B= 200, C= 300.

The minimum slope for any open channel shall be 1:200 and preferably 1:100.

- 9.4.16 The location of the open channel shall comply with the formation shoulder distance. Where track drainage is incorporated within existing track constraints (e.g. cuttings) and the shoulder distance cannot be achieved, open channels are to be an adequate distance from the track to prevent ballast spill into the channel area. In this case, the edge of the channel closest to the track shall be a minimum of 3200mm from the design track centre.
- 9.4.17 The material forming the open channel shall be capable of withstanding the maximum permissible design velocity. The Table below gives maximum velocity values for varying lining types.

TABLE 9 - MAXIMUM PERMISSIBLE VELOCITIES

Channel Material	Velocity (m/s)
Fine sand	0.45
Silt loam	0.60
Fine gravel	0.75
Stiff clay	0.90
Coarse gravel	1.20
Shale, hardpan	1.50
Grass Covered	1.8
Stones	2.5
Asphalt	3.0
Boulders	5.0
Concrete	6.0

- 9.4.18 Minimum fall for any drain or open channel shall be 1:200 to 1:100 as noted. The maximum designed depth of a drain should generally not be in excess of 4.5m below ToR. To minimise the depth of drains then suitable connector and cross drains shall be designed and constructed.
- 9.4.19 All cess drainage systems must be designed to discharge to an approved watercourse or existing drainage system, and the approval of the appropriate authority must be obtained.
- 9.4.20 In areas where there are multiple tracks, the track enclosed by other tracks shall have sub-surface drains running longitudinally to collect rainfall and carry it away from the track. Drainage may be provided by sumps and pipes in between each alternate track. See details below in Sub-surface Drainage Design.

9.5 SUB-SURFACE DRAINAGE DESIGN & INSTALLATION

- 9.5.1 Sub-surface drains are used where adequate surface drainage cannot be provided due to some restriction or lack of available fall due to outlet restrictions.
- 9.5.2 Sub-surface drain (Type 1) shall be installed between tracks 1 & 3 and tracks 2 & 4 at all stations for the full length of the side tracks
- 9.5.3 Sub-surface drain (Type 2) shall extend under the full length of the mainline and side track turnouts that lead from tracks 1 & 2 to side tracks 3 & 4 and side tracks 3 & 4 to yards.
- 9.5.4 Cross drains with manholes shall be installed at regular intervals to ensure adequate fall for the drain, adequate disposal of water, ease of maintenance, and to keep drain depths to a minimum.
- 9.5.5 Manholes can be manufactured from brickwork, blockwork, reinforced concrete or pre-cast concrete and shall be designed to have a minimum design life of 70 years. Each manhole shall have a steel frame incorporated into its top into which a cover shall fit.
- 9.5.6 Every manhole shall have a cover that is flush (+/- 50mm) with the adjacent ground or ballast level. The cover shall be designed for a 50kN wheel load. The cover shall be made from reinforced pre-cast concrete (min grade M35) and shall have an outer steel frame made from angle iron. Lifting handles shall be incorporated into the cover.
- 9.5.7 Sub-surface drainage shall also be provided in locations where the water table is at or near earthworks level.
- 9.5.8 Sub-surface drainage shall be provided along the cess, between, across, or under tracks as required. With multiple tracks, drainage may be provided by sumps and pipes in between each alternate track.
- 9.5.9 The sub-soil drainage network typically consists of perforated pipes and a discharge system such as an outfall or soakaway.
- 9.5.10 Drainage pipes are to be a minimum of 300mm in diameter. The pipes shall be perforated with suitable bedding and surround.
- 9.5.11 The network shall have sufficient capacity to discharge flows, in accordance with the Design Criteria.
- 9.5.12 Sub-surface drainage systems shall be designed to take surface runoff, ground water and seepage, and water collected from other drainage systems to which the new system is being connected. Most systems will only have to cater for surface runoff.
- 9.5.13 If a drainage system is required to remove ground water and seepage, a detailed hydrological and geotechnical investigation is required to determine the volume of water for the sizing of drains.

9.5.14 Typical Sub-Surface Drainage:

Details of Subsurface Drainage/Yeraltı drenajın təfərrüatları

S = 1:50

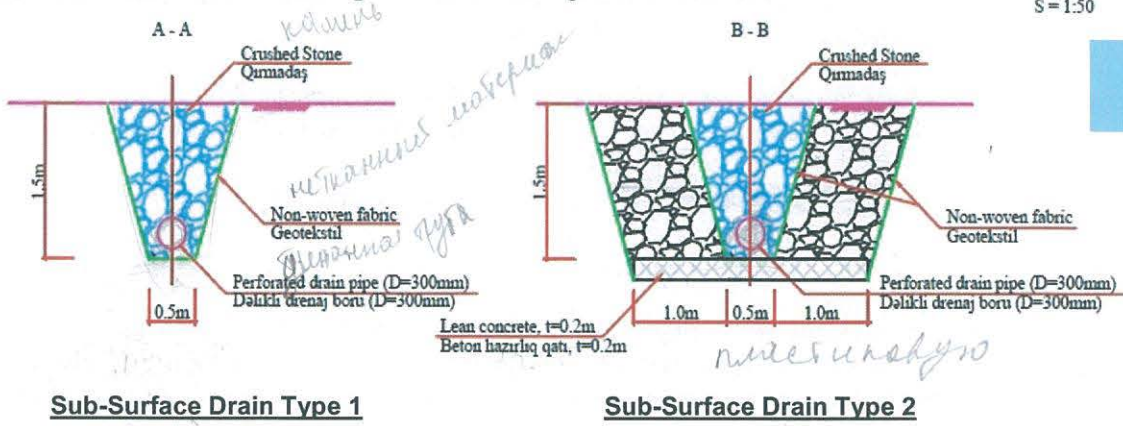

9.6 CULVERT & PIPES DESIGN REQUIREMENTS

- 9.6.1 Types of pipe materials should be in accordance with the standards of the local relevant authorities. Steel and cast iron pipes shall not be used. Pipes shall comply with the following standards: EN 476, EN 1295, and EN 1610.
- 9.6.2 Where the depth of excavation exceeds 1.2m the Contractor shall:
- i. Batter back the sides of the excavation to a gradient compatible with the angle of repose of the soil or,
 - ii. Support the sides of the excavation with a system of sheet piling, trench sheeting and shoring or,
 - iii. Adopt a combination of these.
- 9.6.3 The capacity of the proposed drainage system shall be determined using the peak flow rate calculated by the Rational Method, with adjustment made for sub-surface water and water collected from other systems. The peak flow velocity within the pipe shall be less than the manufacturer recommended maximum limits
- 9.6.4 Pipes larger than the design size may be adopted to reduce the likelihood of the system becoming blocked and also enable easier cleaning. The minimum pipe diameter shall be 225mm (for ease of maintenance cleaning).
- 9.6.5 The desirable slope of pipes shall be 1 in 100. Where this is not achievable, the pipe shall be laid at the maximum achievable slope. Slopes flatter than 1 in 200 require approval of the Engineer.
- 9.6.6 Desirable depth of pipes under the track shall be 1600mm minimum from ToR to top of pipe or pipe encasing.
- 9.6.7 Desirable depth of pipes running parallel to the track shall be 600mm minimum from the design cess level to top of pipe.
- 9.6.8 At specific sites where it is not feasible to comply with these desirable pipe depth requirements and achieve an effective drainage system design, the pipe depth may be reduced to:
- 1200mm minimum from top of rail to top of pipe or pipe encasing for under track pipes; provided the pipe strength quality permits the railway loading at this depth.
 - 300mm minimum from the design cess level or 1000mm from top of adjacent rail (whichever produces the lowest invert level) to top of pipe for pipes running parallel to the track, provided the pipe strength quality permits the railway loading at this depth.
- 9.6.9 All drainage culverts shall be designed for the required flow capacity determined from the hydrological study with the consideration of climate change developments. Locations and type of culvert shall consider ongoing maintenance requirements. Calculations and details shall be included in the Design Reports.
- 9.6.10 Precast concrete culverts of all types shall be manufactured in accordance with local standards or approved international standards.

- 9.6.11 Skewed culverts shall be avoided where possible. Maximum culvert skew to be 30 degrees from the perpendicular to the railway centreline.
- 9.6.12 Drainage structures are to be reviewed to confirm that there are no areas of additional risk to the road or railway track.
- 9.6.13 The Contractor shall provide attenuation storage for treated drainage flows collected from any Facility in the absence of any utility stakeholder external drainage network.
- 9.6.14 The Contractor shall provide all necessary pumps, treatment facilities, settling/evaporation ponds, liners as is necessary to ensure that drainage flows meet regulatory requirements.
- 9.6.15 The drainage system shall collect all rainwater from the Facility building roofs, impermeable areas within the Facility site, and runoff from external areas.

9.7 OPEN CHANNELS (INCLUDING TRENCHES, DITCHES AND SPILL WAYS)

- 9.7.1 Open channels can be V shaped, U shaped or of rectangular cross sections typically.
- 9.7.2 Open channels shall be designed to carry the peak flow from the catchment being drained without overtopping.
- 9.7.3 The side slopes of open channels shall be determined following assessment of the safe angle of repose of soils and the prevailing site conditions.
- 9.7.4 Open channels can be unlined and lined. If unlined the design must demonstrate that the velocity is low and the silting of the channel will be very slow. Where velocity is high the open channels shall be lined with stone pitching, pre-cast concrete units or other approved soil protection to prevent scour.
- 9.7.5 Lining shall be riprap, stone pitching, in-situ concrete or precast concrete.
- 9.7.6 The selection of lining material shall take into account:
 - a) The need for reducing turbulence by reducing velocity of flow (riprap and stone pitching),
 - b) The need to provide smooth surface to maintain velocity and,
 - c) The desire for self-cleansing (concrete surfaces).
- 9.7.7 Following the hydrological investigation and detailed design, the Concrete ditches shall be installed in the Station areas (according to the above typical cross section) and the open ditches shall be laid on open line both side of the tracks in accordance with the above cross sections.
- 9.7.8 Concrete linings shall be in accordance with applicable local standards or similar approved international standards.
- 9.7.9 Runoff from track formed areas shall be via surface channels.

9.7.10 Typical drains that are recommended for use include the following:

- a) Bottom ditch drain: A = 600mm C = 400mm

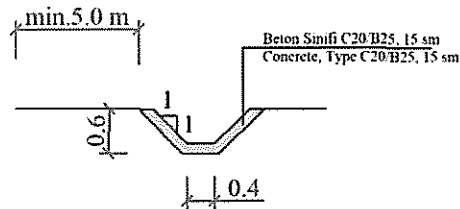

Dib küveti
Bottom ditch

- Bottom ditches shall be installed where the design is required to channel the water to the nearest watercourse and prevent erosion of the channel.
- Minimum grade for Bottom Ditch is 1:100

- b) Lined drainage ditch

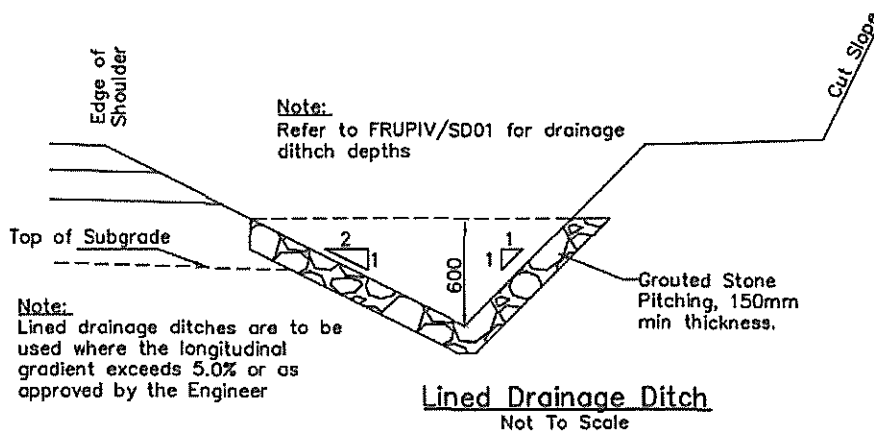

Type 1 Lined Drainage Ditch - 600mm deep x 1200mm wide

Type 2 Lined Drainage Ditch - 800mm deep x 1600mm wide

- Lined drainage ditches shall be installed where the design is required to channel the water to the nearest watercourse and prevent erosion of the embankment.
- Minimum grade for Lined Drainage Ditch is 1:100
- The Contractor may design and install other lined drainage ditches provided the 2:1 rule is maintained for sizing.

9.8 UTILITY CROSSING DRAINAGE

- 9.8.1 Locations for utility crossings shall be determined by the Contractor as an interface with utilities companies and agreed and approved by ADY and the Engineer.
- 9.8.2 Where the rail crosses utilities the rail track and its associated facilities are required to be protected against flooding from burst pipes.

9.9 EARTHWORKS FOR DRAINAGE CONTROL

- 9.9.1 Earthworks design and construction for drainage control shall include but not limited to retention ponds, cut-off drains, open drains, diversion drains, stream training, bunds, retention ponds, soakaway ponds, culvert levees and guide banks. Some earthworks may be required outside of the ADY RoW to ensure proper waterway control.
- 9.9.2 The Contractor shall design all the earthworks required for Drainage Control and submit the designs. The final Design Package will then be issued for implementation.

9.10 DRAINAGE BOX CULVERTS

- 9.10.1 Drainage culverts are to be provided along the alignment at low points where flow paths meet the alignment, and shall be designed to carry the railway traffic with applicable load factors applied.
- 9.10.2 The findings of the Hydrological Study will define the peak flows to be carried by these culverts and the hydraulic calculations will advise the culvert size, slope, inlet and outlet conditions etc.

9.11 BOX CULVERT INSTALLATION

- 9.11.1 All box culverts shall be four-sided pre-cast culverts. No in-situ construction for box culverts shall be permitted. Two sided box culverts shall be permitted only for existing utilities where it is not practical to place a four sided culvert.
- 9.11.2 All culverts shall be excavated and installed in accordance with the relevant Local Standards and Codes of Practice, or in their absence with relevant International Standards, and in compliance with the Contract Specifications.
- 9.11.3 Bedding of well graded granular material in accordance with the Contractor's Design Report and approved by the Employer shall be supplied and placed for all culverts and slabs.
- 9.11.4 Bedding shall be compacted to Modified Dry Density ratio of 95% or greater.
- 9.11.5 The Precast Sections shall be installed whole and not cut to suit specified length.
- 9.11.6 Precast culverts shall be laid in accordance with manufacturer's instructions and good practice.
- 9.11.7 Jointing shall be sealed with proprietary sealants recommended by the manufacturer.
- 9.11.8 The specified culvert length shall be rounded up to a whole multiple of a unit length.

9.11.9 All reinforced concrete drainage structures shall be wrapped with an approved waterproofing membrane for durability purposes.

9.11.10 The Contractor shall backfill and compact over the culverts a minimum of 600mm in accordance with the Contractor's Design Report and in accordance with UIC 719 design and construction standard and gain the Engineer's approval.

9.12 MANHOLES, CHAMBERS & GULLIES (INLETS) ЛЮКИ, ОТСЕКИ И ЛИВНЕВЫЕ СПУСКИ (ВХОДНЫЕ ОТВЕРСТИЯ)
Люки, отсеки и ливневые спуски(входные отверстия) должны быть сконструированы следующим образом:

9.12.1 ЛЮКИ И ОТСЕКИ

- a) При каждом изменении градиента или направления
- b) При каждом изменении диаметра
- c) На каждом пересечении с другими трубами

9.12.2 СПУСКИ(ВХОДНЫЕ ОТВЕРСТИЯ)

- a) В самой низкой точке возвышения и промежуточных местоположений
- b) На возвышении наружного рельса и переходов
- c) На пересечениях дорог, расположенных в точке наименьшего возвышения

9.13 SOAKAWAYS ДРЕНАЖНЫЕ КОЛОДЦЫ

9.13.1 Подрядчик должен спроектировать и построить отвод в соответствии с применимыми местными стандартами или утвержденными международными стандартами, такими как BRE Digest 365

9.13.2 Дренажные колодцы должны быть построены в соответствии с утвержденным стандартом

**9.14 ОТСТОЙНЫЕ, ФИЛЬТРУЮЩИЕ, ИСПАРИТЕЛЬНЫЕ БАСЕЙНЫ
RETENTION, ATTENUATION AND EVAPORATION PONDS**

9.14.1 Отстойные, фильтрующие, испарительные бассейны должны быть спроектированы и установлены в местах, где это требуется в соответствии с гидрологическим исследованием

9.14.2 Отстойные/Фильтрующие/Испарительные бассейны должны быть установлены не ближе чем 30 метров от ближайшего магистрального пути

9.14.3 Бассейны должны быть спроектированы таким образом, чтобы минимальный надводный борт превышал максимальный расчетный верхний уровень воды не менее 150 мм.

9.14.4 Фильтрующие, испарительные бассейны должны быть спроектированы так, чтобы они выполняли функции отстойников в местах, где воздействие выдуваемого ветром песка может привести к скоплению песка и пыли на осушенных участках.

9.14.5 Отстойники должны быть предусмотрены для защиты от песка, пыли и других частиц, попавших в поток ливневых вод

9.14.6 Они должны быть установлены дальше чем бензоуловители и насосные станции. Отстойники должны быть облицованы гравием или защитным покрытием из камня, чтобы облегчить удаление отложений с помощью экскаваторных машин.

МИКРО ТОННЕЛЛИНГ и ТРУБОПРОВОД

9.15 MICRO TUNNELLING AND PIPE JACKING

- 9.15.1 Если Подрядчик решит принять или должен предпринять микротоннелирование или подъем труб в качестве метода прокладки труб, то дополнительная информация должна быть предоставлена Инженеру для согласования
- 9.15.2 Подрядчик должен предоставить подробную информацию о геотехнических исследованиях в виде результатов по скважинам для каждой пусковой / приемной ямы.
- 9.15.3 Подрядчик также должен провести геофизические исследования вдоль предложенного маршрута, чтобы предоставить информацию о наличии слоев почвы и наличие или отсутствие пустых мест.
- 9.15.4 Должно быть предоставлено подтверждение независимого геотехнического эксперта, привлеченного Подрядчиком, для подтверждения того, что микротоннелирование или прокладка труб подходят для почвенных условий.
- 9.15.5 Предложения Подрядчика также должны содержать подробную информацию о пробных исследованиях для определения существующих услуг.
- 9.15.6 Работы по прокладке труб и микротоннелированию должны выполняться в соответствии с утвержденными местными или международными стандартами. Примеры международных стандартов включают в себя:
- a) Ассоциация по прокладыванию труб, Великобритания: руководство по передовой практике прокладки труб и Микротоннелирование;
 - b) Ассоциация по прокладыванию труб, Великобритания: введение в сборку труб и проектирование микротоннелирования.

9.16 PETROL AND OIL INTERCEPTOR УСТРОЙСТВО ОТСЕЧКИ НЕФТИ И БЕНЗИНА

- 9.16.1 Загрязнение поверхностных вод бензином, нефтью, химикатами или твердыми веществами может привести к тому, что эти загрязнения окажут серьезное влияние на прием воды. Отсечка представляет собой "ловушку" для отделения углеводородных загрязнителей от стока дождевой воды.
- 9.16.2 Предоставление, расположение и размеры отсеков должны определяться местом любых утечек из тех участков, где существует риск загрязнения, и требованиями местных властей, например, МЭПР.
- 9.16.3 Конструкция и установка отсека нефти должна соответствовать местным стандартам или международным стандартам.
- 9.16.3.1 устройства для фильтрации нефти от воды не должно иметь движущихся частей и должно быть рассчитано на потоки без регулировки клапанов, диффузоров, тавотниц и т. д.
 - 9.16.3.2 На станциях с высоким уровнем загрязнения балласта и / или нижних подбалластных слоев устройство отсека нефти (фильтрации) будет установлено в конце дренажной системы, чтобы предотвратить попадание загрязненной воды в местные канализационные системы или водные пути..

9.17 STORM WATER PUMPED SYSTEMS ГИДРОАККУМУЛИРУЮЩАЯ СИСТЕМА СТОЧНЫХ ВОД

- 9.17.1 Следует избегать использования гидроаккумулирующей системы для сточных вод, однако там, где это необходимо, насос будет накапливать ливневую воду и на насосной станции будет установлен сток до ближайшей подходящей точки сброса.

- 9.17.2 Насосные станции будут спроектированы в соответствии с требованиями местных органов власти и представлены в отчете по проектированию для согласования с Инженером.

ЗАЩИТА УСТРОЙСТВ ОТСЕЧКИ И НАСОСНОГО ОБОРУДОВАНИЯ

9.18 PROTECTION OF INTERCEPTORS AND PUMPING EQUIPMENT

- 9.18.1 Оборудование для сбора мусора и просеивание должно быть предусмотрено для устройств отсеки и возле насосных станций

- 9.18.2 Оборудование для мусора должно иметь место, куда будут сбрасываться тяжелые твердые частицы, песок, которые могут быть отсечены от потока воды.

- 9.18.3 Устройство отсеки должно фильтровать любые оставшиеся твердые частицы из потока.

- 9.18.4 Защитный экран должен предотвращать прохождение любых твердых частиц диаметром более 6 мм.

9.19 SCOUR AND EROSION CONTROL КОНТРОЛЬ ЭРОЗИИ И ЗАСОРОВ

- 9.19.1 Подрядчик несет ответственность за проведение гидрологических оценок, разработку и конструирование мер по предотвращению засоров и эрозии.

- 9.19.2 На этапе проектирования проектировщик должен выполнить расчет пиковой скорости стока, возникающего во время штормов.

- 9.19.3 Там, где скорость потока превышает допустимые уровни, и может произойти засор почвы, проектировщик должен предоставить проекты мер по предотвращению эрозии.

- 9.19.4 Должны соблюдаться руководящие принципы местных дренажных органов, касающиеся максимально допустимой скорости потока над почвой.

- 9.19.5 Канавы и каналы должны быть выровнены там, где существует риск размывания.

- 9.19.6 Облицовка должна выполняться с использованием камня, и шва заполненного раствором.

- 9.19.7 Водосточные трубы должны быть снабжены стенками крыльев подпорной стенки на входе и выходе для обеспечения перехода между более высокими скоростями в водопропускной трубе и более низкими скоростями, приемлемыми в без облицовочных областях.

- 9.19.8 Должны быть предусмотрены гасители энергии потока, где скорости потока могут превышать 5 м / с.

- 9.19.9 Возможность засора во всех сооружениях должна быть изучена Подрядчиком.

- 9.19.10 В случае возможного риска засора или эрозии Подрядчик должен разработать меры защиты для конструкции. Меры защиты могут включать в себя: геотекстильные решетки для укрепления траншей, засыпка бетона вокруг уязвимых элементов, балки снизу и на краю конструкции рядом с потоком.

ЗАСОРЫ НА ЭТАПЕ УСТАНОВКИ

9.20 SCOUR RISKS AT CONSTRUCTION STAGE

- 9.20.1 Строительные работы могут вызвать засоры.

- 9.20.2 Эти риски могут возникнуть, если Подрядчик препятствует существующим путям потока из за чего происходит засорение канализации и потоков в определенной области.

- 9.20.3 Подрядчик должен оценить существующие пути потока ливневых вод до начала работ на этом участке.

- 9.20.4 Должно быть подготовлено заявление о методе управления ливневыми водами, в котором будут определены все пути потока, меры по защите целостности путей потока во время строительных работ.
- 9.20.5 Если работы должны выполняться на пути потока, такие как строительство / восстановление мостов или водопропускных труб, Подрядчик должен подготовить план для включения в Заявление о методе управления ливневыми водами для отвода и управления потоками во время работ.
- 9.20.6 Строительство отвалов и железнодорожных насыпей может значительно повлиять на уровень паводковых вод.
- 9.20.7 Заявление о методе управления ливневыми водами должно включать в себя уровни наводнений и потенциал увеличения уровня паводков на этапе строительства и во время эксплуатации I этапа железной дороги.
- 9.20.8 Там, где существует риск увеличения затопления, Подрядчик должен разработать и реализовать меры по предотвращению ущерба.
- 9.21 OUTFALL STRUCTURES ВЫПУСКНОЕ СООРУЖЕНИЕ**
- 9.21.1 Подрядчик должен исследовать, спроектировать и построить подходящие соединения в существующую смежную систему ливневой канализации.

ЖЕЛЕЗНОДОРОЖНЫЕ ПЕРЕЕЗДЫ (ЖП)

10 LEVEL CROSSING (LC) (Refer to **Appendix 11** for further Details)

Для подробной информации см. Приложение 11

- 10.1 There are ten (10) No. level crossings to be constructed in Lot 1.
Есть 10 железнодорожных переездов которые необходимо построить в Лоте 1
- 10.2 Объем работ Подрядчика охватывает работы по пересечению дорог, включая удаление существующих железнодорожных переездов, где используемый материал не подходит. Конструкционные пути и их панели из резины / полимера или бетона со стальными рамами и местами подъема для облегчения демонтажа рельс должны быть спроектированы и установлены на железнодорожных переездах. Резиновые / полимерные переходы должны использоваться там, где это указано в таблице ниже.
- 10.3 Дорожные указатели, подъездные пути, дренаж, ограждения, ворота и т. Д. Должны быть спроектированы и установлены. Шлагбаумы, сигналы, вывески и любые механические или автоматические системы безопасности дорожного движения не входят в сферу действия Подрядчика, но должны выполняться другими, так что Подрядчик должен тесно сотрудничать с Заказчиком, чтобы обеспечить полную интеграцию железнодорожных переездов, систем и соответствующих монтажные работ с работой Подрядчика.
- 10.4 Обозначение уровня пересечения должно соответствовать с международным союзом железных дорог UIC 760 - "Знаки железнодорожного переезда"
- 10.5 Подъездные дороги без опечатывания на каждой стороне переезда должны быть реконструированы Подрядчиком и заделаны асфальтобетоном на спроектированной и подготовленной дорожной основе с дренажом. Длина асфальтированного участка должна составлять не менее 50 метров в длину, измеряемой от края панелей конструкции железнодорожного переезда, и, по крайней мере, такой же ширины, что и железнодорожный переезд. Эта реконструированная дорога должна быть полностью спроектирована и утверждена как часть окончательного проекта и чертежа.
- 10.6 Для загороженных подъездных дорог на каждой стороне переезда необходимо реконструировать и загерметизировать асфальтобетон на специально спроектированной и подготовленной дорожной основе длиной не менее 50 метров, измеренной от края железнодорожного переезда, и, по крайней мере, той же ширины, что и железнодорожный переезд, с соответствующим дренажом. Эта реконструированная дорога должна быть полностью спроектирована и утверждена как часть окончательного проекта и чертежа.
- 10.7 Каждая подъездная дорога в точке 40 метров с каждой стороны переезда должна быть спроектирована и изготовлена Подрядчиком для ограничения скорости (например, с помощью ограничителя скорости) таким образом, чтобы транспортное средство снижало скорость до примерно 20 км / ч или меньше. Детали должны быть включены как часть окончательного дизайна и чертежа.
- 10.8 Железнодорожный переезд должен быть оборудован конструкционными панелями, расположенными между двумя ходовыми рельсами и на боковой стороне, проходящими от центральной линии пути минимум на 1900 мм к стороне и по всей ширине между путями. Панели могут быть изготовлены из бетона или резины / полимера с защитными стальными рамами и местами подъема для удобства. Монтаж / демонтаж, в соответствии со следующими принципами системы иллюстрации(см рисунок), требованиями местных отделов дорожного движения и работодателя.



Principle System Illustration: Level Crossing in Main Running Lines

Пример установки: Железнодорожный переезд в месте главных ходовых линий

- 10.9 Железнодорожные переезды должны быть панельного типа, которые легко устанавливаются и удаляются ручными методами. Панели должны быть спроектированы таким образом, чтобы учитывать динамическое воздействие профиля колеса при скорости и нагрузке на ось, указанных в Требованиях Работодателя, без смещения с места их нахождения. Система должна включать панели внутри колеи, панели за пределами колеи, системы удержания балласта и переходы на прилегающие общественные или частные дороги.

Таблица 10 - доп информация по железнодорожным переездам
Table 10 - Level Crossing Details

Железно-
дорожный
переезд №

Level Crossing No.	Chainage пикетаж	Width in metres (Min) ширина в метрах(мин)	приблизительная длина в метрах(мин) Length Metres (Min)	Тип Type
23	2539+300	7.0	9.42	Concrete Бетон
24	2544+700	7.0	9.42	Concrete
25	2550+000	8.0	9.42	Rubber/Polymer Резина/Полимер
26	2554+600	7.0	9.42	Concrete Бетон
27	2569+700	7.0	9.42	Concrete
28	2579+800	8.0	9.42	Rubber/Polymer Резина/Полимер
29	2584+800	7.0	9.42	Concrete Бетон
30	2592+000	8.0	9.42	Rubber/Polymer Резина/Полимер
31	2596+300	7.0	9.42	Concrete Бетон
32	2602+800	8.0	9.42	Rubber/Polymer Резина/Полимер

- 10.10 Сигнализация и каналы электропитания должны быть установлены на всех железнодорожных переездах. Подробная информация о воздуховодах приведена в Приложении 1. Расположение воздуховодов должно быть определено путем взаимодействия с Подрядчиком по сигнализации, или, если Контракт на сигнализацию еще не заключен, Отдел инфраструктуры АЖД предоставит детали через Инженера.

See **Appendix 11** for Level Crossing locations and relevant details.

Месторасположение и важная информация об железнодорожных переездах см. Приложение 11

Железнодорожные переезды в месте пересечения животными (для доп информации см. Приложение 11)

11 ANIMAL CROSSINGS (AC) – (Refer to Appendix 11 for further Details)

- 11.1 Есть девять(9) железнодорожных переездов в месте пересечения животными которые необходимо построить в Лоте 1.
- 11.2 Объем работ Подрядчика охватывает работы по переездам в месте пересечения животными, включая все проектирование и установку данных переездов. Структурные панели пути с местами подъема для облегчения снятия для трамбовки должны быть спроектированы и установлены на переездах в месте пересечения животными. Знаки, подъездные пути, дренаж, ограждения, ворота и т. Д. Должны быть спроектированы и установлены Подрядчиком.
- 11.3 Переезд в месте пересечения животными должен быть построен из панелей с соответствующей конструкцией с учетом нагрузки на панели. Панели конструкции должны быть непрерывными по всем линиям, расположенным между двумя ходовыми рельсами и со стороны ходовых рельсов. Панели должны проходить как минимум на 5000 мм от центральной линии пути до ворот с каждой стороны перехода.
переезда
- 11.4 Панели должны иметь не скользкую поверхность и могут быть изготовлены из бетона или резины / полимера с защитными стальными рамами и местами подъема для удобства монтажа / демонтажа трамбовки.
- 11.5 Ворота (минимум 4.0 м) шириной должны быть установлены по обе стороны от переезда в месте пересечения животными, а также должны быть открытыми с помощью канала для движения затвора быть самозакрывающимися после того, как канал отпущен, и могут быть надежно заблокированы без блокировки ключа когда закрыты. Угловое ограждение должно быть установлено с каждой стороны ворот шириной 2 м, чтобы направлять животных на переезд и с него.
- 11.6 На азербайджанском языке у ворот на каждой стороне пути должны быть установлены большие предупреждающие знаки, чтобы давать советы лицам, использующим переезд следующим образом:
- Остерегайтесь поездов!
 - Свяжитесь с поездным диспетчером перед переездом - Введите номер телефона диспетчера.
 - Откройте широко ворота перед тем, как запустить скот на пересечение
 - Пересечение скота осуществляется с разрешения диспетчера
 - После пересечения закройте все ворота
- 11.7 Для того, чтобы животные не стояли на пути (а не просто их пересекали) на пути должны быть установлены подходящие защитные ограждения для животных, например, высокие заборы, решетки для крупного рогатого скота, шипы и т. д., однако они должны быть расположены в пределах габаритной конструкции для линии. Типичные примеры приведены на фотографии ниже



Таблица 11 - информация по переездам в месте пересечения животными
Table 11 - Animal Crossing Details

Переезд в месте пересечения животными №	Animal Crossing	Chainage	Ширина в метрах (мин)	Тип
	No.	пикетаж	Width in metres (Min)	Type
	3	2540+000	2.0	Бетон или резина/Полимер Non-slip concrete or rubber/polymer
	4	2548+400	2.0	
	5	2555+800	2.0	
	6	2560+500	2.0	
	7	2565+000	2.0	
	8	2578+100	2.0	
	9	2580+400	2.0	
	10	2590+400	2.0	
	11	2622+600	2.0	

11.8 Average length of Animal Crossings: 14.1 metres

Средня длина переезда в месте пересечения животными: 14.1 метр

11.9 Сигнализация и электроэнергия должны быть установлены на всех переездах в местах пересечения животными. Подробная информация об электроэнергии показана в Приложении 2. Расположение трубопроводов должно определяться вместе с Подрядчиком по сигнализации, или, если Контракт на сигнализацию еще не заключен, отдел инфраструктуры АЖД предоставит информацию через Инженера.

See **Appendix 11** for Animal Crossing locations and relevant details.

для месторасположения и информации по переездам в местах пересечения животными см Приложение 11.

12 LINESIDE ACCESS ROAD

The Contractor shall design, construct, and hand-over an unpaved all-weather lineside access road parallel to one side of the railway line within the RoW, in locations where agreed with the Employer/Engineer.

12.8 CRITERIA

Criteria for the lineside access road are set out below.

- i. The lineside access road predominately provides access to bridges and culverts.
- ii. The lineside access road need not always be on the same side of the railway line.
- iii. Access from a public road must always be available to the lineside access road.
- iv. Where the railway is within 50m of a public road there is generally no need for an access road.
- v. Access to a public road should be no greater than 2km intervals to accommodate any maintenance and rescue vehicles.
- vi. The design should aid in minimising dust generated from vehicular movement.
- vii. The width of the lineside access road shall not be less than 3.6m with appropriate passing bays of 6m width where practical.
- viii. The unpaved road shall be suitable for emergency and maintenance vehicles and four axle trucks.
- ix. At locations where there is insufficient space for the lineside access road to run directly parallel to the railway, e.g. below overpasses, then vehicular access may need to be made available around the overpasses and its approach ramps or other similar locations.
- x. The Contractor shall design and construct the lineside access roads together with the lineside drainage system in areas of high ground water levels ensuring a stable, durable and accessible unpaved road is maintained at all times.
- xi. The Contractor shall obtain stakeholder approval wherever the lineside track is crossing any Utilities or private property.
- xii. When constructing an access road, no tree shall be felled, damaged or up-rooted, and no vibratory rollers shall be used, without the written authority of the Employer.

13 LINESIDE FENCING

13.8 The Contractor shall design, supply and install on both sides of the railway track and within the RoW, at locations defined by the Engineer, lineside fencing to prevent unrestricted access to the track and trespassing of people, livestock or other animals to BS1722 or other approved national or international standard.

13.8.1 There are two types of Lineside Fencing – Type 'A' and Type 'B'

13.8.2 All types of fencing (Type 'A' and Type 'B') and locations are to be approved by the Engineer.

- 13.8.3 Transitions between different types of fence shall as much as possible have a seamless transition to provide a consistent approach.
- 13.8.4 All fence types shall be resistant and robust against the aggressive climatic conditions. All steel posts and rails shall be hot dip galvanised.
- 13.8.5 Both Type 'A' and Type 'B' fences shall be equipped with 4.5m wide lockable, double-gates, or as per Stakeholder Requirements. Gates shall be located on each side exit / entry of the lineside access roads, property boundaries, underpasses, overpasses, and animal crossings.
- 13.8.6 Both Type 'A' and Type 'B' fences shall be equipped with 1.4m wide lockable single gates for pedestrian access. Gates shall be located on each side exit / entry of the lineside access roads, property boundaries, underpasses, overpasses, and animal crossings.

13.9 LINESIDE FENCING & GATES – TYPE 'A' (Stations and Urban Areas)

- 13.9.1 The Contractor shall design and construct a 2m high chain link or similar fence along the Final Right-of-way boundary, around accesses, crossings, gates, all lineside structures, on both sides of the railway, in stations and urban areas only, the extent of which shall be proposed by the Contractor and agreed and approved by the Engineer
- 13.9.2 The design requirements shall be based on Azerbaijan authorities standards related to Fencing and Gates and shall prevent unauthorised access to track areas and railway facilities. See **Appendix 11** for details.
- 13.9.3 All design and location details for the Type 'A' fencing are to be approved by the Engineer.
- 13.9.4 Transitions between different types of fence (Type "A" to Type "B") shall as much as possible have a seamless transition to provide a consistent approach.
- 13.9.5 The fence shall be stable, with concrete foundations.
- 13.9.6 Strainer posts must be used at:
- a) Ends of fencing
 - b) Angles in fencing
 - c) Abrupt changes in grade
 - d) Intersections with other fences
 - e) Gates and other intermediate points along a straight fence line but not exceeding 100m
 - f) Strainer post must be braced against an intermediate post in two (2) directions for all cases, except for ends of fences and gates where only one direction is suitable.
- 13.9.7 The Contractor shall provide gated access through the fence at intervals not exceeding 500m, or to the reasonable requirements of ADY and the Engineer.

- 13.9.8 The height of the gate shall match the height of the fence, i.e. 2m
- 13.9.9 The fencing material of the gate shall match the adjacent fencing properties.
- 13.9.10 For each gate the Contractor shall provide locks with each 5 keys.

13.10 LINESIDE FENCING & GATES – Type B (Open Line Areas)

13.10.1 The Contractor shall design and construct a strained wire 1.5m high steel post and wire fence along the final Right of Way boundary, in locations identified and agreed with the Engineer around accesses, crossings, gates, all lineside structures, on both sides of the railway, in open line locations to BS1722 or other approved national or international standard. Refer to **Appendix 11** for details.

13.10.2 The design requirements shall be based on Azerbaijan authority standards related to Fencing and Gates and shall prevent unauthorized access to track areas and railway facilities.

- a) Maximum spacing between posts is 3.5m;
- b) The fence shall have at least six (6) strands of galvanized wire, equally spaced;
- c) Wire shall be galvanized high tensile barbed wire at least 4mm diameter, with a minimum breaking strain of at least 3kN, tensioned to at least 1.3kN and without excessive sag.

13.10.3 All design and location details for the Type 'B' fencing are to be Engineer approved.

13.10.4 Transitions between different types of fence (Type "A" to Type "B") shall as much as possible have a seamless transition to provide a consistent approach.

13.10.5 All fence types shall be stable with concrete foundations approved by the Employer.

13.10.6 All fence types shall be resistant against the aggressive climatic conditions.

13.10.7 The fences shall be equipped with 4.5m wide lockable, double-gates, and 0;9m pedestrian gates, as per Stakeholder Requirements. Gates shall be located on each side exit / entry of the lineside access roads, underpasses, overpasses, and animal crossings.

13.10.8 Strainer posts must be used at:

- a) Ends of fencing
- b) Angles in fencing
- c) Abrupt changes in grade
- d) Intersections with other fences
- e) Gates and other intermediate points along a straight fence line but not exceeding 100m
- f) Strainer post must be braced against an intermediate post in two (2) directions for all cases, except for ends of fences and gates where only one direction is suitable.

13.10.9 The Contractor shall provide gated access for pedestrians and vehicles through the fence at intervals not exceeding 5km, or to the reasonable requirements of ADY and the Engineer.

13.10.10 The fencing material of the gate shall match the adjacent fencing properties. .

13.10.11 For each gate the Contractor shall provide locks with each 5 keys.

14 PEDESTRIAN OVERPASS BRIDGES

14.8 On nominated Main Stations, pedestrian overpasses shall be designed and constructed to facilitate the crossing of the people from one platform to other platforms and/or to cross the railway line. Certain overpasses shall include an elevator at each end, and to platforms, to aid people with reduced mobility to cross the railway and access station platforms.

14.9 The images below are examples of the Employer's type and style preference.

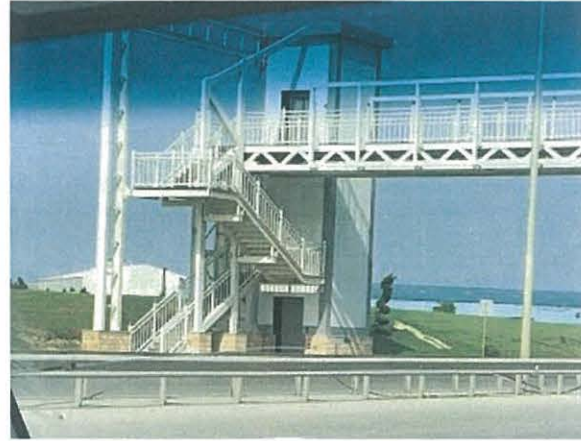

The Table below sets out the footbridge / Pedestrian overpass proposed details.

TABLE 14 PEDESTRIAN OVERPASS BRIDGES

No.	Km	Station Name	Type	Platform Access	Length of Overpass (metre)	Height from Top of Rail to the lowest part of the structure (metre)	Comment
1	2620+855m	Sungait station	Pedestrian Overpass	2 Platforms	100	8.5	Pedestrian Bridge with 2 No. Elevators for Access
2	2612+550m		Pedestrian Overpass		33	8.5	Pedestrian Bridge
3	2610+722m	H.Z.Tağıyev station	Pedestrian Overpass	2 Platforms	60	8.5	Pedestrian Bridge
4	2579+065m	Gilazi station	Pedestrian Overpass	2 Platforms	65	8.5	Pedestrian Bridge
5	2559+648m	Siyazan station	Pedestrian Overpass	1 Platform	56	8.5	Pedestrian Bridge
6	2548+800m	Qiziburun station	Pedestrian Overpass	2 Platforms	65	8.5	Pedestrian Bridge with 3 No. Elevators for Access
7	2538+705m	Gil-Gil chay station	Pedestrian Overpass	Nil	54	8.5	Pedestrian Bridge
Total Elevators							5

- 14.10 Length of overpass is approximate only. Details to be determined on site by the Contractor.
- 14.11 Elevator and stair access shall be provided to station platforms as noted in Table 14.
- 14.12 The minimum inside clear width of any pedestrian overpass bridge on the pedestrian accessible route is 2400mm.
- 14.13 Each overpass shall be designed to accommodate an elevator at each end, whether an elevator is to be installed under this Contract or a later contract.
- 14.14 The sides of all stairs shall be enclosed.
- 14.15 No roof covering is required for pedestrian overpasses.
- 14.16 All pedestrian overpass steelwork shall be hot-dip galvanised and epoxy painted steel structures.
- 14.17 Any concrete works shall be pre-cast with polished finish. Any insitu concrete works shall be steel trowel finish.
- 14.18 No puddling of water is permitted in any location where pedestrians will walk.
- 14.19 The overpass design shall ensure that overall maintenance requirements for the structure and elevators are low with ease of maintenance.
- 14.20 Design life is 70 years for the structure.

PART 4

TECHNICAL SPECIFICATION - CONSTRUCTION SITE REQUIREMENTS

1 THE SITE

- 1.1 The Site is defined in the Contract. The Site is bounded by the ADY right-of-way for the main lines and tracks 3 and 4 at Stations.
- 1.2 Various yards/areas may be made available to the Contractor for the Contractor's use. These yards/areas can be identified by the Contractor and request made to the Employer. The Employer is under no obligation to agree to provide any areas for the Contractor's use, and in which case alternative locations will need to be acquired by the Contractor.
- 1.3 The layout and use of all yards/areas made available to the Contractor by the Employer (if any) shall be agreed with the Engineer.
- 1.4 The timings, sequence and conditions relating to the Contractor's possession of the Site are variously set out in the Conditions of Contract and **Appendix 2**.

2 USE OF THE SITE

- 2.1 The Site shall not be used by the Contractor for any purposes other than for carrying out the Works, except with the consent in writing of the Engineer.
- 2.2 The location and size of each stockpile of materials, including excavated materials and equipment within the Site shall be as permitted by the Engineer.
- 2.3 Stockpiles shall be maintained at all times in a stable condition, free from contamination by other material.
- 2.4 Plant and Materials shall be stored in a clean and dry condition until installed in the Works, unless otherwise approved by the Engineer.
- 2.5 Entry to and exit from the Site shall be controlled and shall be only available at the locations accepted by the Engineer.

3 ACCESS TO THE SITE

- 3.1 The Contractor shall make its own arrangements, subject to the consent of the Engineer, for any access required to the Site, and the Railway Envelope located on the Site.
- 3.2 The Contractor shall ensure that access to every portion of the Site is continually available to the Employer and Engineer.
- 3.3 Following the hand-over of the Railway Envelope, (as defined in Part 1 – Technical Specification - General), to the Contractor, the Contractor will control the Railway Envelope and will be responsible for all matters relating to security and safety therein.
- 3.4 Access to the Railway Envelope by the Contractor shall be in accordance with any procedures, requirements and conditions defined by ADY regulations.

4 ACCESS TO OUTSIDE THE SITE

- 4.1 The Contractor shall be responsible for ensuring that any access or egress through the Site boundaries is controlled such that no disturbance to residents or damage to public or private property occur as a result of the use of such access or egress by its employees and sub-contractors.
- 4.2 The Contractor shall ensure that vehicles leaving the Site are clean and will not carry mud and debris from the site so that it falls from the vehicles and affects the cleanliness of the environment. Vehicle washing facilities may be required, and this shall be implemented at no additional cost if the Engineer so directs.
- 4.3 All loads leaving the site shall be covered to prevent dust and debris being discharged from the vehicle.

5 SURVEY OF THE SITE

- 5.1 A survey shall be carried out of the Site to establish its precise boundaries of the ADY right-of-way.
- 5.2 This survey shall include a photographic survey sufficient to provide a full record of the state of the Site before commencing the work with particular attention paid to those areas where reinstatement will be carried out later on.
- 5.3 The survey shall be carried out by the Contractor and agreed with the Engineer before the site clearance wherever possible and in any case prior to the start of the Works.
- 5.4 All survey operations, field and off-site, must be carried out in accordance with DIN 9001:2015. All measurements, calculations and reports should be documented in accordance with the requirements of the QM DIN ISO 9001:2015.

6 SITE FENCING AND SIGNBOARDS

- 6.1 The Contractor shall maintain security of his works including fencing of the Site to the requirements of the railway operator.
- 6.2 No work shall be commenced until the Engineer has been satisfied that the fencing or appropriate safety and security measures installed by the Contractor are sufficient to prevent, within reason, unauthorised entry or affect existing train operations. '
- 6.3 Project signboards shall be erected not more than four (4) weeks, or such other period as the Engineer has given his consent, after the Date of Commencement.
- 6.4 The types, sizes and locations of project signboards shall be agreed with the Engineer before manufacture and erection and the signboards shall comply with the guidelines of the Employer and the requirements of the various Authorities.
- 6.5 The costs for all signboards shall be to the Contractor's account.
- 6.6 Other advertising signs shall not be erected on the Site.

6.7 Fences, gates and signs shall be maintained in good order by the Contractor until the completion of the Works, whether such hoardings, fences, gates and signs have been installed by the Contractor or by others and transferred to the Contractor during the period of the Works.

6.8 All temporary fences, gates and signs installed by the Contractor shall be removed by the Contractor upon the completion of the Works, and the area restored to original condition.

7 CLEARANCE OF THE SITE

7.1 All Temporary Works which are not to remain on the Site after the completion of the Works shall be removed prior to completion of the Works or at other times as required by the Contract.

7.2 The Site shall be cleared and reinstated to the lines and levels and to the same condition as existed before the Works started except as otherwise stated in the Contract.

8 SURVEY

8.1 Before the Contractor commences the setting out of the Works, Engineer will issue available documents showing the position of all known and available survey reference point and benchmark, together with the co-ordinates.

8.2 The Contractor shall satisfy itself that there are no conflicts between the data given and shall establish and provide all subsidiary setting out points, monuments, towers and the like which may be necessary for the proper and accurate setting out and checking of the Works,

8.3 The Contractor shall carefully protect all the survey reference points, benchmarks, setting out points, monuments, towers and the like from damage and shall maintain and promptly repair or replace any points damaged from any cause whatsoever.

8.4 The Contractor shall regularly recheck the position of all setting out points, benchmarks and the like to the satisfaction of the Engineer,

8.5 Upon handover to the Contractor, the survey reference points will become the responsibility of the Contractor.

8.6 The Contractor shall, by frequent re-survey, ensure that these survey points continue to remain consistent.

8.7 Prior to installation of the track, the Contractor shall provide permanent survey markers (control point monuments) along the track as described in **Appendix 23**.

8.8 These permanent benchmarks will be used for maintenance of the track and will be sufficiently robust to avoid displacement during construction.

8.9 Prior to the completion of the Works the Contractor will recheck the permanent survey markers and issue a record of the coordinates, level and exact coordinates of each permanent survey marker to the Engineer.

9 ENVIRONMENTAL REQUIREMENTS

- 9.1 The Contractor shall comply in all respects with the Acts and Regulations issued by the Government of Azerbaijan and its authorised agents in respect of the protection of the environment.
- 9.2 Particular requirements applicable to this Contract for the protection of the environment during construction are defined in **Appendix 13**.
- 9.3 The Ministry of Ecology and Natural Resources of the Republic of Azerbaijan (MENR) and its regional branches could impose financial and legal sanctions, in accordance with the applicable legislation in Azerbaijan, onto the Contractor if MENR requirements are not observed.

10 RAILWAY POSSESSIONS

- 10.1 The Contractor will comply with **Appendix 15**, Railway Possessions, for all work within the vicinity of the operating railway and shall obtain the written permission of the Operator, and ADY for any work within the right-of-way.
- 10.2 The Engineer shall be provided with a copy of the Railway Possession applications and permissions as generated. The Contractor shall note the timeframes required to apply for possessions and allow for this period in the project programme.
- 10.3 The Contractor shall provide personnel to oversee, supervise and report on the Track Possessions, on a full-time basis. At each station located at the beginning and end of a possession, or if the possession is in a station, the Contractor shall have at least one full-time person located at that location to co-ordinate and relay messages from ADY to the Contractor's personnel (and vice-versa) working on the possession.
- 10.4 Each of these personnel shall be termed a Contractor's Operations Person In-Charge (COPIC).
- 10.5 The COPIC shall keep written records of the Track Possession details. Details include:
- i. Possession Location
 - ii. ADY Possession Contact
 - iii. Possession Start time and Date
 - iv. Possession end time and Date
 - v. Contractor's daily start time at the possession for each work front
 - vi. Train Operation details
 - vii. Train Operational Incidents
 - viii. Details of ADY instructions and time received
 - ix. Any safety related incidents or matters
 - x. Other relevant details
- 10.6 No additional payment shall be made for COPIC's as their cost is deemed to be included in the Contractor's overhead.

11 SAFETY MEASURES - GENERAL

- 11.1 The Contractor shall engage a full-time Health & Safety Manager reporting directly to the Contractor's Representative, with at least fifteen (15) years' experience in working on safety aspects around railways and with railway operational safety experience. Additional appropriate staff, to manage, co-ordinate and report on Safety will also be required. All safety staff shall undergo the necessary safety and Railway Safe Working training and be certified for the duties that they undertake.
- 11.2 The cost of implementation and compliance with all safety matters shall be to the Contractor's account.
- 11.3 The Contractor shall comply with all ADY Safety Requirements and Railway Safe Working requirements when working on or near the operating railway.
- 11.4 The Contractor shall implement and comply with all safety requirements as per the legislation of the Republic of Azerbaijan.
- 11.5 The Contractor shall be fully responsible for the safety of the Works, his personnel, sub-contractors' personnel, the public and all persons directly or indirectly associated with the Works on or in the vicinity of the Site.
- 11.6 The Contractor shall comply with the requirements of Appendix 12: "Requirements for Site Safety Plan", provided that the standards set out in Appendix 12 shall be regarded as the minimum to be achieved and shall not relieve the Contractor of any of his statutory duties or his responsibilities under the Contract.
- 11.7 The provisions of the Contract regarding safety shall apply to and are binding upon the Contractor for any part of the Works and the persons employed by its sub-contractors.
- 11.8 The Contractor shall ensure that the requirements of the Contract in respect of safety are included in all sub-contracts placed by him.
- 11.9 The Engineer reserves the right to order the immediate removal and replacement of any item of Contractor's Equipment or Temporary Works which, in his opinion, is in an unsafe condition or does not comply with the assumed principles and Employer regulations.

12 LEGISLATION AND CODES OF PRACTICE

- 12.1 The Contractor shall comply with all safety and industrial health legislation including, without limitation, the Regulations of Labour Protection and Safety issued by the relevant Ministries, as well as all Employer's standards, regulations and requirements. The European norms shall be used in case that there is no Azerbaijan equivalent and it shall be provided by the Contractor in English and Azeri translation.
- 12.2 The Contractor shall keep on the Site copies of safety and industrial health regulations and documents. All regulations and documents referred in this sub-clause shall be translated into languages which are understood by the operators engaged by the Contractor or sub-contractors and such translations shall be displayed or kept alongside those in the Azeri and English languages.

13 SITE SAFETY PLAN

- 13.1 The Contractor shall, within four (4) weeks from the date of Date of Commencement, prepare and submit to the Engineer for review, his proposed Site Safety Plan which shall contain as a minimum those items set out in the Project Safety Manual and as detailed in Appendix 12.
- 13.2 The Contractor shall develop a series of Key Performance Indicators (KPI) to monitor their Safety Performance against a series of agreed targets. The KPI shall include the measure of the Lost Time Injury Frequency Rate (LTIFR). The European or Russian Railway Industry LTIFR shall be used as a benchmark for the Safety KPI, as well as others that the Contractor and the Engineer can propose and mutually agree as appropriate measures. The Contractor's safety performance will be measured against the agreed benchmarks. Failure by the Contractor to consistently achieve the safety benchmarks will be grounds for the Employer/Engineer to instruct changes to the Contractor's management team.
- 13.3 The LTIFR is determined as per the formula below:

$$\frac{\text{(Number of lost time injuries in accounting period)}}{\text{(Total hours worked in accounting period)}} \times 1,000,000 = \text{LTIFR}$$

- 13.4 The Contractor shall always update and submit to the Engineer the Site Safety Plan before the start of a new works location at various parts of the Site.
- 13.5 The Contractor shall appoint a Safety Officer (Accident Prevention Officer) reporting to the Contractor's Safety Manager, as required under Sub-Clause 6.7 of the General Conditions of Contract, whose duties throughout the period of the Contract shall be entirely connected with the safety and industrial health aspects of the Contractor's activities on the Site.
- 13.6 The Safety Manager appointment shall be within twenty-eight (28) days of the Date of Commencement and shall be subject to the Engineer's written consent.
- 13.7 The Contractor shall not undertake any works on the Site until the Safety Manager has commenced duty.
- 13.8 The Safety Officer's appointment shall be within eighty-four (84) days of the date of acceptance of Tender and shall be subject to the Engineer's written consent.
- 13.9 The Safety Officer shall be a suitably qualified and experienced person, familiar with construction safety matters as well as railway safety matters who shall supervise and monitor compliance with the Site Safety Plan.
- 13.10 The Contractor shall not remove the Safety Manager or the Safety Officer from the site without the express permission of the Engineer, and without having an approved replacement to commence immediately.
- 13.11 The Safety Officer shall, in particular but without limitation, carry out railway safety and construction safety auditing of the operation of the Site Safety Plan in accordance with a rolling programme to be submitted, from time to time, to the Engineer for his consent.

- 13.12 The Contractor shall not remove the Safety Manager or the Safety Officer from the site without the express permission of the Engineer, and without having an approved replacement to commence immediately.
- 13.13 The Safety Officer shall stay at the site during the Defects Notification Period, as well as during the construction suspension if there is any.
- 13.14 The Contractor shall provide the Safety Officer with supporting staff trained in construction safety as well as railway safety matters in accordance with the staffing levels set out in the Site Safety Plan, the supporting staff shall include at least one (1) Deputy Safety Officer whose appointment(s) shall be subject to the Engineer's consent.
- 13.15 The Deputy Safety Officer(s) shall be capable of assuming the duties and functions of the Safety Officer as contained in the Site Safety Plan whenever necessary.
- 13.16 The Contractor shall empower the Safety Officer and safety staff to instruct employees of the Contractor or of its sub-contractors to cease operations in unsafe conditions.
- 13.17 The Safety Officer shall be empowered and take immediate and appropriate action to make safe the Site and prevent unsafe working practices, in particular around an operating railway environment, or other infringements of the Site Safety Plan or the statutory regulations.
- 13.18 The Contractor shall ensure that the Safety Officer maintains a daily site safety diary for each work site, which shall comprehensively record all relevant matters concerning site safety, railway safety, safety inspections and audits, safety related incidents, near misses, and the like.
- 13.19 The site safety diaries for the various work sites shall be reviewed and signed on a weekly basis by the Safety Manager and Contractor's Representative and shall be available always for inspection by the Engineer, Employer and Azerbaijan authorities who can add remarks in the diaries which shall be obligatory for the Contractor to implement.
- 13.20 If the Contractor does not comply with those remarks the Contract for the Works can be terminated for breach of contract, and only the work implemented up to this moment will be paid.
- 13.21 The site safety diary for each site shall be kept in English and Azeri.
- 13.22 The Contractor's Staffing Organisation Plan shall show direct lines of communication and reporting between the Safety Officer, Safety Manager and the Contractor's Representative.
- 13.23 The Contractor shall instruct and require the Contractor's Representative to be directly accountable in all matters concerning site safety for all of the Works.

14 SITE SAFETY INSPECTIONS

- 14.1 The Contractor will conduct site safety and railway safety inspections at a regular frequency.
- 14.2 The findings of the inspections shall be recorded on suitable forms which shall be kept available for inspection by the Engineer.

15 SAFETY ACCIDENT/INCIDENT REPORTING

- 15.1 The Contractor shall submit regular site safety reports to the Engineer in accordance with the Site Safety Plan. Such reports shall be submitted as part of the Monthly Progress Report. Site safety reports shall comprehensively address all relevant aspects of site safety and industrial health regulation and, in particular, report on all site safety audits undertaken during the period covered by the report. The report shall also include details on:
- Train Operations incidents;
 - Railway safety incidents and near misses;
 - Road vehicle incidents and near misses;
 - Property damage incidents;
 - Reportable incidents related to flora and fauna;
 - Incidents related to OCS and any damage thereto;
 - Incidents related to the signalling system and damage thereto;
- 15.2 The Engineer shall be notified by the Contractor immediately of the occurrence of any safety incidents whether on-site or off-site in which the Contractor, its personnel or plant, or those of its sub-contractors are directly or indirectly involved and which results in any injuries to any persons or damage to property. Such initial notification may be verbal and shall be followed by a written comprehensive report within twenty-four (24) hours of the accident.
- 15.3 The ADY Chief Safety Inspector and the relevant Azerbaijan authorities (police, first aid/ ambulance, fire department etc.) shall also be notified verbally and in writing and he shall assist them in every way.
- 15.4 If the incident causes a railway traffic interruption, the Contractor will assist with staff and plant to the ADY Safety department to recovery the railway traffic.

16 SUB-CONTRACTORS

- 16.1 The Contractor shall provide its sub-contractors with copies of the Site Safety Plan and shall incorporate into all sub-contract documentation, provisions to ensure the compliance with plan.
- 16.2 The Contractor shall require all sub-contractors to be trained in construction safety and railway safety matters.
- 16.3 The Contractor shall require all sub-contractors to appoint a safety representative who shall be available on the Site throughout the operational period of the respective sub-contract.
- 16.4 The Contractor's Safety Manager, Safety Officer and safety staff, without prejudice to their other duties and responsibilities, shall ensure that employees of sub-contractors of all tiers are conversant with appropriate parts of the Site Safety Plan and the statutory regulation.

17 SAFETY MEETINGS

- 17.1 The Contractor shall convene regular safety meetings in accordance with the Safety Plan and shall require attendance by the Safety Officer and safety representatives of sub-contractors unless otherwise agreed by the Engineer.
- 17.2 All safety meetings shall be notified in advance to the Engineer when may attend in person or by representative at his discretion.
- 17.3 The minutes of all safety meetings shall be sent to the Engineer within seven (7) days of the meeting.
- 17.4 A Site Safety Management Committee may be established by the Engineer to monitor the implementation of the Safety Plan. The Engineer or his representative will be chairman of this committee and the members can include the Contractor's agent or representative, Safety Officer and sub-contractor's safety personnel.

18 SAFETY EQUIPMENT

- 18.1 The Contractor shall ensure that all safety equipment and Personal Protective Equipment (PPE) and clothing as required by the Safety Plan is available and used on the site always.
- 18.2 The Contractor shall ensure those safety personnel working on the track as flagmen and lookouts shall have all the safety equipment, flags, lights, warning devices and other safety items as required by ADY regulations.
- 18.3 The Contractor shall ensure that measures for the effective enforcement of proper utilisation and necessary replacement of such equipment and clothing are incorporated into the Site Safety Plan.
- 18.4 The Contractor shall regularly inspect, test and maintain all safety equipment, scaffolds, guard-rails, working platforms, hoists, ladders, masks, helmets, signalling cloth, signs (boards, flags etc.) audible signals, safety belts, isolating gloves, earthing rob, etc. and other means of access and egress, lifting, lighting, signage and guarding equipment. Lights and signs shall be kept clear of obstructions and be legible.
- 18.5 Safety signage shall be written in both Azeri and English and must be legible.
- 18.6 Equipment which is damaged, dirty, incorrectly positioned or not in working order shall be repaired or replaced immediately.

19 FIRST AID

The Contractor shall establish, maintain, staff, and fully equip a first aid base as detailed in **Appendix 10** or he will present a contract, approved by the Engineer for such service.

20 SITE SAFETY PUBLICITY

- 20.1 The Contractor shall ensure that safety, rescue and industrial health matters are given a high degree of publicity to all persons regularly or occasionally on the Site.
- 20.2 Posters, in Azeri and English, drawing attention to site safety, rescue and industrial health regulation shall be made or obtained from the appropriate sources and shall be displayed prominently in relevant areas of the Site.
- 20.3 These posters shall be changed on a regular basis in order to ensure their continued impact.

21 TRAINING

- 21.1 The Contractor shall conduct regular safety training and rescue training drills, the frequency, coverage and application of which shall be in accordance with the Site Safety Plan, and in any case, shall be at least every six months.
- 21.2 The Contractor shall require that all sub-contractor's employees participate in relevant training courses appropriate to the nature, scale and duration of the sub-contract works.

22 BREACH OF SAFETY REGULATIONS

- 22.1 Any personnel employed by the Contractor or sub-contractor who commit a serious breach of the safety regulations shall be liable to summary dismissal and shall not be re-employed on the Contract or allowed on any of the Sites and advisory signs of this sanction shall be prominently displayed on the Site.
- 22.2 The same applies to the incidents causing the train traffic interruption. If the incident is repeated or is extremely serious, the contract could be terminated and only the work implemented up to this moment will be paid.

23 SAFETY DEVICES

- 23.1 All plant and equipment used on or around the Site shall be fitted with appropriate safety devices which shall be operational at all times and shall be regularly inspected and tested. These shall include amongst others:
 - a) effective safety catches for crane hooks and other lifting devices;
 - b) earthing systems for all temporary electrical equipment and power sources;
 - c) functioning automatic warning devices and, where applicable, up-to-date test certificates, for cranes and rail mounted vehicles;
 - d) All plant and equipment used on or around the Site shall be operated by suitably trained and qualified personnel.

24 TESTING AND CERTIFICATION OF LIFTING GEAR

- 24.1 The Contractor shall provide and maintain mechanical cranes, hoists and conveying facilities for the lifting and transport of materials and shall comply with all relevant requirements of his country relevant standard and the relevant standards in Azerbaijan.
- 24.2 All cranes, hoists and the like shall be fitted with audible overload warning devices and shall have protection against high-voltage lines and all such equipment shall be regularly maintained in accordance with manufacturers' recommendations and standards having regard to local legislation and recommendations from the appropriate statutory authority.
- 24.3 Prior to use on Site, all lifting appliances and lifting gear shall be tested to an approved safety margin and suitably identified in accordance with the requirements of the current legislation.
- 24.4 The safe working load shall be clearly and indelibly marked on all lifting appliances and lifting gear either by stamping or by the addition of permanently secured tag labels and stamping shall not be permitted on any stress-bearing part.
- 24.5 The Contractor shall prepare and maintain an up-to-date register containing test certificates of all lifting and hoisting equipment used on the Works.
- 24.6 The Contractor shall notify the Engineer of the person responsible for maintaining this register and the register shall, from the start of construction, be available on Site for inspection by the Engineer and Relevant Authorities.
- 24.7 Heavy plant or equipment which does not come under the jurisdiction of any local statutory legislation shall be subject to the testing and examination requirements as recommended by its manufacturer and in the absence of such recommendation, it shall be the responsibility of the Contractor to submit a standard or method of testing and examination to the Engineer for review.
- 24.8 Competent operators shall be provided for the control of all lifting and hoisting equipment who shall be certified that they have received training in the general principles of crane operation and specific training in the type of lifting or hoisting equipment.
- 24.9 At least one trained lookout shall be in attendance at each lifting or hoisting installation.

25 FIRE REGULATIONS AND SAFETY

- 25.1 The Contractor shall provide and maintain all necessary temporary fire protection and firefighting facilities on the Site during the construction of the Works and shall comply with all requirements of local fire regulations.
- 25.2 These facilities may include, without limitation, sprinkler systems and fire hose reels in temporary site buildings, raw water storage tanks and portable fire extinguishers suitable for the conditions on the Site and potential hazards.
- 25.3 The Contractor shall submit details of these facilities to the Engineer for review prior to beginning of work on the Site.

- 25.4 If, in the Engineer's opinion, the use of naked lights may cause a fire hazard, the Contractor shall take such additional precautions and provide such additional firefighting equipment (including breathing apparatus) as the Engineer considers necessary.
- 25.5 The term "naked light" shall be deemed to include electric arcs and oxyacetylene or other flames used in welding or cutting metals.
- 25.6 Oxyacetylene burning equipment will not be permitted in any confined space, in these cases burning equipment of the oxy-propane type shall be used.

26 DANGEROUS GOODS AND RADIATION

- 26.1 The Contractor shall ensure that all gases, fuels, explosives and other dangerous goods are stored and handled in a safe manner and in accordance with the statutory regulations and as required by the Engineer.
- 26.2 The Contractor shall be responsible for obtaining the requisite licences and permission to store and handle such substance.
- 26.3 No use of radioactive substances and radiating apparatus or operation involving ionizing, electromagnetic radiation or X-rays shall be carried out without the prior consent of the Engineer and the Contractor shall ensure that all personnel and members of the public are properly protected from the effects of any such radiation when authorised.
- 26.4 Each radiation area shall have conspicuous signs and barriers.
- 26.5 The Contractor shall submit for review by the Engineer details of the training given to nominated employees on the safe use, handling, transport and storage of dangerous goods, radioactive substances, radiation and X-ray equipment prior to their introduction on Site, such training shall include the necessary measures to be taken in case of emergency.

27 HAZARD AND RISK ASSESSMENTS

- 27.1 For all high-risk works the Contractor shall produce a detailed hazard and risk assessment for these operations and shall submit this to the Engineer for his consent prior to beginning of the task to which they relate.
- 27.2 The Contractor shall, prior to the beginning of any operation which will interfere with existing train operations, carry out a detailed hazard and risk assessment and the results of such assessments shall be recorded and the records kept for inspection by the Engineer.
- 27.3 The Contractor shall produce and implement a Permit to Work system for all high-risk operations.
- 27.4 The Permit to Work system shall be submitted to the Engineer for consent before application.

28 EXPLOSIVES

- 28.1 Explosives shall not be used without the prior written consent of the Engineer.
- 28.2 Before consent to blasting is granted, the Contractor shall prepare a Specification as to the storage, size of charge, the method of firing and any other restrictions that may be imposed from time to time.
- 28.3 The explosive works shall be implemented by certified local firm or persons who will be hired by the Contractor.
- 28.4 Where the Engineer has consented to the use of explosives, the Contractor shall be responsible for obtaining the requisite licences and permits for complying with all statutory requirements for blasting.
- 28.5 The storage, transportation and use of explosives shall at all times be governed by the Explosives Acts and such other statutory regulations which may be applicable and as imposed by the Statutory Authorities.

29 STAND-BY EQUIPMENT

- 29.1 The Contractor shall provide adequate stand-by equipment to ensure the safety of personnel, the Works and the public when working below ground, these measures shall include as a minimum the following:
 - a) stand-by pumping and generating equipment for the control of water;
 - b) stand-by equipment and spares for illumination of the Works; and
 - c) stand-by generating equipment and equipment for the lighting and ventilation of confined spaces or underground works.

30 PROTECTION OF THE WORKS FROM WEATHER

- 30.1 Unless otherwise permitted by the Engineer all work shall be carried out in dry conditions.
- 30.2 The Works shall be protected from damage due to weather and the effects of water. Any water on the Site and water entering the Site shall be promptly removed by temporary drainage or pumping systems or by other methods capable of keeping the Works free of water.
- 30.3 Silt and debris shall be removed by silt traps before the water is discharged and shall be disposed of at a location or locations to which the Engineer has given his consent.
- 30.4 The discharge points of the temporary systems shall be as permitted by the Engineer.
- 30.5 The Contractor shall make all arrangements with and obtain the necessary approval from the relevant authorities for discharging water to drains, watercourses etc.
- 30.6 The relevant work shall not be commenced until the approved arrangements for disposal of the water have been implemented.
- 30.7 The methods used for keeping the Works free of water shall be such that settlement of, or damage to new and existing structures do not occur.
- 30.8 Measures shall be taken to prevent flotation of new and existing structures.

- 30.9 Work shall not be carried out in weather conditions that may adversely affect the Works unless proper protection is provided to the satisfaction of the Engineer.
- 30.10 Permanent Works, including materials for such Works, shall be protected from exposure to adverse weather conditions.
- 30.11 During the construction of the Works, storm restraint systems shall be provided where appropriate, these systems shall ensure the security of the partially completed and ongoing stages of construction in all-weather conditions.
- 30.12 Such storm restraint systems shall be installed as soon as practicable and shall be compatible with the right-of-way, or other access around or throughout the Site.

31 DAMAGE AND INTERFERENCE DUE TO THE WORKS

- 31.1 Work shall be carried out in such a manner that there is no damage to or interference with:
- a) Adjacent residences, structures and properties;
 - b) Watercourses or drainage systems;
 - c) Utilities;
 - d) Structures (including foundations), roads, including street furniture, or other properties;
 - e) Public or private vehicular or pedestrian access;
 - f) Monuments, trees, graves or burial grounds;
 - g) Other than to the extent that is necessary for them to be removed or diverted to permit the execution of the Works.
- 31.2 The Contractor shall, before commencement of construction activities, undertake a dilapidation survey of any residences, structures or properties near the railway that may be affected by the Works. Detailed photographic and written records shall be maintained in the event of a claim from a third party claiming the Works resulted in damage. The extent of the dilapidation survey is to be determined by the Contractor.
- 31.3 Heritage structures shall not be damaged or disfigured on any account.
- 31.4 The Contractor shall inform the Engineer as soon as practicable of any items which are not stated in the Contract to be removed or diverted but which the Contractor considers need to be removed or diverted to enable the Works to be carried out.
- 31.5 Such items shall not be removed or diverted until the consent of the Engineer to such removal or diversion has been obtained.
- 31.6 The Contractor shall suspend his work until the Archaeological Institute and museum, local authorities and Engineer give their instructions.
- 31.7 Items which are damaged or interfered with as a result of the Works and items which are removed to enable work to be carried out shall be reinstated by the Contractor at his cost, to the satisfaction of the Engineer and to at least the same condition as existed before the work started.

32 UTILITIES

- 32.1 The Contractor shall lead the liaison and interface with all utility organisations as part of its interface management requirements.
- 32.2 The Contractor shall make his own enquiries and investigations, including excavating trial holes, discovering of existing underground structures, equipment, etc. with special devices (cable seekers), to ascertain the existence, nature, location and size of utilities.
- 32.3 The Contractor shall design and construct any utility protection and accommodation work required for utilities that cross the tracks or traverse any part of ADY RoW as agreed with the Engineer.
- 32.4 A schedule of utility diversions and utilities to remain or to be supported in place will be prepared by the Contractor.
- 32.5 All significant utilities shall be identified on the Site by visible warning signage which shall be protected from damage during the course of the works.
- 32.6 The Contractor shall immediately inform the Engineer and the utility agencies of:
- a) Damage to utilities;
 - b) Leakage of utilities;
 - c) Discovery of utilities not previously identified.
- 32.7 The Contractor shall inform the Engineer of the programme of works of all utility diversions and take all steps to enable the utility diversions to proceed in accordance with the programme.
- 32.8 Records of the existing utilities encountered shall be kept by the Contractor on the Site and a copy provided for the Engineer, the records shall contain the following details:
- a) Location of utility;
 - b) Date on which the utilities were encountered;
 - c) Nature and sizes of the utilities;
 - d) Condition of utility;
 - e) Temporary or permanent supports provided; and
 - f) Diversions made -temporary or permanent.
- 32.9 The Contractor shall include the details (plan, location, ownership, size and material) of all such utilities on the As-Built Drawings.
- 32.10 The Contractor shall establish, as a part of the as-built drawings, a cadastre of all structures on the site.
- 32.11 The Contractor shall establish, as a part of the as-built drawings, a cadastre of all structures on the site.
- 32.12 A cadastral drawings copy shall be submitted to the Cadastre Agency in accordance with A cadastral drawings copy shall may be required to be submitted to the Cadastre Agency in accordance with the applicable legislation in Azerbaijan.
- 32.13 The damages caused to any utilities during the construction shall be reinstated and financially compensated to the owner by the Contractor without Employer reimbursement.

33 STRUCTURES, ROADS AND OTHER PROPERTIES

The Contractor shall immediately inform the Engineer of any damage to structures, roads or other properties and shall undertake immediate activities for their reinstatement in original condition at the Contractor's own cost

34 ACCESS & DIVERSIONS

- 34.1 Alternative access shall be provided to all premises if interference with the existing access, public or private, is necessary to enable the Works to be carried out, the arrangements for the alternative access shall be as agreed by the Engineer and the concerned agency.
- 34.2 Unless agreed otherwise, the permanent access shall be reinstated as soon as practicable after the work is complete. The alternative access shall be removed immediately if it is no longer required, and the ground surface reinstated to the satisfaction of the Engineer.
- 34.3 Proper signage and guidance shall be provided for the traffic / users regarding diversions.
- 34.4 Temporary traffic interruptions of more than six hours shall be supported by an alternative transport mode / route which shall be the Contractor's responsibility.
- 34.5 The procedure for usage of alternative transport shall be agreed with the "Freight Transportation Department of ADY"
- 34.6 The public should be informed at least one week earlier.

35 REMOVAL OF GRAVES AND OTHER OBSTRUCTIONS

- 35.1 The Contractor shall draw the Engineer's attention to any graves and other obstructions which are required to be removed in order to execute the Works, and it shall not itself remove them unless the Engineer has given consent.

36 PROTECTION OF ADJACENT STRUCTURES AND WORKS

- 36.1 The Contractor shall take all necessary precautions to protect existing structures, railway operations or works being carried out by others adjacent to and, for the time being, within the Site from the effects of vibrations, undermining and any other earth movements or the diversion of water flow arising from its work.
- 36.2 During all the Works care shall be taken to minimise any disturbance to the signalling system (cables, impedance bonds, signal poles etc.) and the Overhead Catenary System (OCS poles, traction return cables etc.).
- 36.3 Any disturbances to signalling or Overhead Catenary System (especially the OCS poles) shall be made good, and any damage shall be immediately reported to the Engineer and ADY maintenance personnel so the damage can be corrected. The Contractor shall be responsible for all costs associated with the repair of damages to signalling and/or OCS equipment.
- 36.4 Any damage that occurs shall be immediately reported and repaired / reinstated at the Contractor's expense.

37 WORK ON ROADS

37.1 TRAFFIC MANAGEMENT PLAN

- 37.1.1 The Contractor shall develop Traffic Management Plans for any works on public roads under the contract. The purpose is to develop a Traffic Management Plan to cope with the traffic disruption as a result of any construction activities requiring traffic management on the roads and neighbourhoods impacted by the construction activities.
- 37.1.2 The Traffic Management Plans shall take into consideration four principles as follows:
- a) Minimisation of inconvenience of road users and interruption to surface traffic through the area impacted by the construction activities;
 - b) The safety of road users in the impacted area is ensured;
 - c) Access to the construction site is facilitated;
 - d) Traffic safety is ensured at each construction site.

37.2 APPROVAL FOR TEMPORARY TRAFFIC ARRANGEMENTS AND CONTROL

- 37.2.1 The Contractor shall make all arrangements with and obtain the necessary approvals from the transport authorities and the Traffic Police Department for temporary traffic arrangements and control on public roads.
- 37.2.2 The Employer will assist in obtaining approvals but cannot guarantee that approval will be forthcoming.

37.3 TEMPORARY TRAFFIC ARRANGEMENTS AND CONTROL

- 37.3.1 Temporary traffic diversions and pedestrian routes shall be surfaced and shall be provided where work on roads or footpaths obstruct the existing vehicular or pedestrian access.
- 37.3.2 The relevant work shall not be commenced until the approved temporary traffic arrangements and control have been implemented.
- 37.3.3 Temporary traffic arrangements and control of work on public roads and footpaths shall comply with the requirements of the Traffic Police; copies of documents containing such requirements shall be kept on the Site at all times.
- 37.3.4 Temporary traffic signs, including road marking, posts, backing plates and faces, shall comply with the requirements of the Traffic Police and should be in accordance with the requirements of the local traffic authorities.
- 37.3.5 All overhead traffic management signs that are fixed to bridges and gantries shall be illuminated at night.
- 37.3.6 Pedestrian routes shall be illuminated at night to a lighting level of not less than 50 lux.
- 37.3.7 Temporary traffic arrangements and control shall be inspected and maintained regularly, both by day and by night; lights and signs shall be kept clean and legible.

- 37.3.8 Equipment which is damaged, dirty, incorrectly positioned or not in working order shall be repaired or replaced promptly.
- 37.3.9 Equipment which is damaged, dirty, incorrectly positioned or not in working order shall be repaired or replaced promptly.
- 37.3.10 Temporary traffic signs, including road marking, posts, backing plates and faces, shall comply with the requirements of the Traffic Police and should be in accordance with the requirements of the local traffic authorities.
- 37.3.11 All overhead traffic management signs that are fixed to bridges and gantries shall be illuminated at night.
- 37.3.12 Pedestrian routes shall be illuminated at night to a lighting level of not less than 50 lux.
- 37.3.13 Temporary traffic arrangements and control shall be inspected and maintained regularly, both by day and by night; lights and signs shall be kept clean and legible.
- 37.3.14 Equipment which is damaged, dirty, incorrectly positioned or not in working order shall be repaired or replaced promptly.

37.4 PARTICULARS OF TEMPORARY TRAFFIC ARRANGEMENTS AND CONTROL

- 37.4.1 The following particulars of any proposed temporary traffic arrangements and control on public roads shall be submitted to the Engineer for consent at least 28 (twenty-eight) days before the traffic arrangements and control are implemented:
- a) Details of proposed traffic diversions and pedestrian routes;
 - b) Details of lighting, signage, guarding and traffic control arrangements and equipment;
 - c) Any conditions or restrictions imposed by Traffic Police or any other relevant authorities;
 - d) Copies of applications, correspondence and approval.

37.5 USE OF ROADS AND FOOTPATHS

- 37.5.1 Public roads and footpaths on the Site on which work is not being carried out shall be maintained in a clean and passable condition.
- 37.5.2 Measures shall be taken to prevent excavated materials, silt or debris from entering the drainage system on roads and footpath and the entry of water to the system shall not be obstructed.
- 37.5.3 Surfaced roads on the Site and leading to the Site shall not be used by tracked vehicles unless protection against damage is provided.
- 37.5.4 All such loads shall be covered or protected to prevent dust being emitted.
- 37.5.5 The wheels of all vehicles shall be washed when necessary before leaving the Site to avoid the deposition of mud and debris on the roads.

37.6 REINSTATEMENT OF PUBLIC ROADS AND FOOTPATHS

- 37.6.1 Temporary diversions, pedestrian access and lighting, signing, guarding and traffic control equipment shall be removed immediately after they are no longer required.
- 37.6.2 Roads, official footpaths and other traffic arrangements and control shall be reinstated to the condition as existed before the work started or as required by the Engineer.

38 SITE ESTABLISHMENT

38.1 CONTRACTOR'S MAIN SITE ACCOMMODATION

- 38.1.1 The Contractor shall provide, erect, maintain and remove the Site accommodation, which may be situated on the ADY right-of-way or provided yard/areas, in a location approved by the Employer/Engineer.
- 38.1.2 Offices shall be at locations agreed by the Engineer and the office accommodation retained during the life of the Works.
- 38.1.3 The Contractor's site offices shall be maintained by him after the completion of the Works upon his discretion, however the closure of any such offices shall not be prior to the issue of the Taking-Over Certificate for the appropriate site, and within one month from issue of said Certificate.
- 38.1.4 The site offices, provided by the Contractor for the Engineer, shall be maintained in accordance with the provisions of **Appendix 18**.
- 38.1.5 Prior to commencing the erection of the Contractor's accommodation, the Contractor shall obtain the consent of the Engineer to the accommodation, including layout, equipment and furnishings proposed by the Contractor.
- 38.1.6 The services of a full-time security guards on a 24 hour x 7 day basis and attendant during office working periods shall be provided at each establishment.
- 38.1.7 The offices, stores, garages, workshops, latrines and etc. located at the site shall be maintained in a clean, stable and secure condition in accordance with **Appendix 8**.
- 38.1.8 Equipment provided for the use of the Engineer shall be maintained in a clean and serviceable condition.
- 38.1.9 Measuring and testing equipment shall be calibrated before use and at regular intervals.
- 38.1.10 Survey equipment shall be maintained by the Contractor's service agent and shall be regularly checked, and equivalent replacements shall be provided for equipment which is not in working order or not in a serviceable condition or is being repaired or serviced.
- 38.1.11 The Engineer's consent shall be obtained before accommodation or equipment is removed. Portable accommodation shall be moved at the times instructed by the Engineer.

38.2 SITE LABORATORIES

- 38.2.1 The Contractor shall ensure the services of laboratories, equipped for the routine testing of sub-base, sub-ballast, ballast, concrete, soil and rock samples and for the storage and curing of concrete cubes and for any other tests as required in the appropriate standards and regulations.
- 38.2.2 These services shall be provided by accredited laboratories in accordance with the Azerbaijan legislation and approved by the Engineer.
- 38.2.3 Tests performed by non-accredited laboratories shall not be accepted.

38.3 LATRINES AND WASH-PLACES

- 38.3.1 The Contractor shall provide latrines and wash-places for the use of its personnel and all persons who will be on the Site.
- 38.3.2 The size and disposition of latrines and wash-places shall accord with the numbers and dispositions of persons entitled to be on the Site, which may necessitate their location on structures. Where necessary there shall be separate facilities for males and females.
- 38.3.3 The capacities and layout shall be in accordance with local regulations.
- 38.3.4 The Contractor shall arrange regular disposal of effluent and sludge in a manner that shall be in accordance with local laws/ regulations.
- 38.3.5 The Contractor shall be responsible for maintaining all latrines and wash-places on the Site in a clean and sanitary condition and for ensuring that they do not pose a nuisance or a health threat.
- 38.3.6 The Contractor shall also take such steps and make such provisions as may be necessary or directed by the Engineer to ensure that vermin, mosquito breeding etc. are at all times controlled.

38.4 SITE UTILITIES AND ACCESS

- 38.4.1 The Contractor shall be responsible for providing water, electricity, telephone, sewerage and drainage facilities for all site accommodation, structures, buildings, site laboratories, if utilised, and all such services that are necessary for satisfactory performance of the Works.
- 38.4.2 The Contractor shall make all arrangements with and obtain the necessary approval from the relevant civil authorities for the facilities.
- 38.4.3 The Contractor shall be responsible for provision of power supply for his works and the Employer cannot guarantee the provision of adequate, continuous power supplies however assistance will be given in obtaining any necessary permissions for site generators and the like.
- 38.4.4 Access roads and parking areas shall be provided within the Site as required and shall be maintained in a clean, acceptable and stable condition. Covered parking for at least six (6) vehicles shall be provided for the Engineer and his staff in a location convenient to the office facility.

38.5 MOBILE PHONE COMMUNICATION

- 38.5.1 The Contractor shall provide mobile phones as the communication system for the exclusive use for the Engineer's project staff. Up to twelve (12) mobile phones shall be provided for the exclusive work use of the Engineer and his staff.
- 38.5.2 The Contractor shall be responsible for obtaining and making all payments in respect of all permits licences and charges involved in the provision and use of the mobile phones provided and for ensuring that such arrangements are safe to use during the use of explosives in construction.

- 38.5.3 The mobile phone system shall be capable of providing the Engineer with interference-free communication and shall be capable of full operation at the Engineer's, Contractor's and Employer's office, and any parts of the Site.
- 38.5.4 The offices shall be provided with recharging facilities, for the equipment mentioned above such that up to twelve (12) handsets can be recharged at any time.
- 38.5.5 The mobile phones shall remain the property of the Contractor and at the Taking-Over of the Works, the mobile phones shall be handed back to the Contractor.

38.6 SUBMISSION OF PARTICULAR DRAWINGS

- 38.6.1 The following particulars shall be submitted to the Engineer for his consent not more than two (2) months after the Date of Commencement:
- a) Drawings showing the formation works and the layout within the Site of the Contractor's offices, project signboards, principal access and other major facilities required early in the Contract, together with all service utilities;
 - b) Drawings showing the layout and the construction details of the Contractor's accommodation; and
 - c) Drawings showing the details to be included on the project signboards and diversion boards.
- 38.6.2 Drawings showing the location of stores, storage areas, concrete batching plants and other major facilities and their access roads/paths shall be submitted to the Engineer for his consent not less than twenty-eight (28) days prior to the date when such facilities are to be constructed on the Site.

39 SECURITY

- 39.1 The Contractor shall be responsible for the security of the Site and all of the Works from the date of possession of the Site until the completion of the Works and shall set up and operate a system whereby only those persons entitled to be on the Site may enter the Site.
- 39.2 Where required the Contractor shall provide and maintain all site boundary fences in good condition.
- 39.3 Warning Signs shall be displayed at intervals around the Site to warn the public of the dangers of entering the Site.
- 39.4 During the progress of the Works, the Contractor shall maintain such additional security patrols over the areas of the Works as may be necessary to protect its own and its sub-Contractor's work and equipment and shall co-ordinate and plan the security of both the work under this Contract and the work of others having access to and across the Site and the Works.
- 39.5 In order to operate such a security system, it will be necessary to institute the issue of unique passes to personnel and vehicles entitled to be on the Site, and which may need to be separately identifiable according to the shifts being worked on Site.

- 39.6 The Contractor shall at the outset determine, together with the Engineer, a system and the design of passes to suit the requirements of the foregoing and to suit the methods of work to be adopted by the Contractor.
- 39.7 The Contractor shall at all times ensure that the Engineer has an up-to-date list of all persons entitled to be on the Site at any time.
- 39.8 The Contractor shall also introduce a system of issue passes to any outsider or person/vehicles belonging to agencies other than Employer's personnel who may have to visit the site in connection with work.
- 39.9 The Contractor shall liaise with the Interfacing Contractors and the Contractors responsible for the adjacent and other interfacing contracts. Interfacing contractors, if required, are entitled to enter the Site, and the Contractor will so allow this, and control their entry, exit and monitor their activities while on the Site.
- 39.10 The Contractor shall ensure that co-ordinated security procedures are operated, in particular in respect of vehicles permitted to pass through the Site and/or the adjacent sites in the latter periods of the Contract.

40 TESTING AND COMMISSIONING (T&C)

40.1 T&C GENERAL

- 40.1.1** The Contractor shall provide and perform all forms of testing procedures applicable to the Works and various components and the interfacing of the Works with the other Contract works and shall conduct all necessary factory, site and acceptance tests.
- 40.1.2** All of the test should be in compliance with the applicable legislation in Azerbaijan and national standards, such as AzDTN/GOST, SNIP, or applicable international standards accepted by the relevant local authorities.
- 40.1.3** The commissioning activity shall include a period of Integrated System testing followed by a one month period of testing as authorised by ADY for staff training and familiarisation and timetable proving purposes.
- 40.1.4** All testing procedures shall be submitted at least thirty (30) days prior to conducting any Test.
- 40.1.5** The Testing procedures shall show unambiguously the extent of testing covered by each submission, the method of testing, the Acceptance Criteria, the relevant drawing (or modification) and the location of testing.
- 40.1.6** The Testing Procedures shall be submitted by the Contractor during the duration of the Contract to reflect changes in system design or the identification of additional testing requirements.
- 40.1.7** The Engineer shall monitor all tests and shall have access to all testing records.
- 40.1.8** The Contractor is reminded that at some point, the 3 kV DC overhead line traction system and the High-voltage Power Supply system will be energised and additional precautions for the safety of personnel and co-ordination of activities after power-on shall be anticipated in its testing and commissioning programmes,
- 40.1.9** The staff shall be trained for working with 3 kV DC traction system, and as the proposed 25kV overhead line traction system is rolled out by an interfacing contractor, it will be necessary for the Contractor's personnel to also be trained in the safe operation and safeworking for 25kV AC overhead traction system if the period of installation overlaps this Project.
- 40.1.10** All the above activities shall be in compliance with any applicable requirements of ADY and the legislation in Azerbaijan.
- 40.1.11** All testing equipment shall carry an appropriate and valid calibration label.
- 40.1.12** All measurement devices shall which shall be delivered by the Contractor should be registered and approved by the Azerbaijan authorities.

40.2 SAMPLES FOR TESTING

- 40.2.1** Samples shall be of sufficient size and in accordance with relevant Standards to carry out all specified tests.

- 40.2.2** Samples taken on the Site shall be selected by, and if required, be taken in the presence of, the Engineer and shall be suitably marked for their identification.
- 40.2.3** An identification marking system should be evolved at the start of works in consultation with the Engineer.
- 40.2.4** Samples shall be protected, handled and stored in such a manner that they are not damaged or contaminated and such that the properties of the sample do not change.
- 40.2.5** Samples shall be delivered by the Contractor to the specified place of testing.
- 40.2.6** Samples on which non-destructive tests have been carried out shall be collected from the place of testing after testing and delivered to the Site or other locations instructed by the Engineer.
- 40.2.7** Samples, which have been tested, may be incorporated in the Permanent Works provided that:
- a) The sample complies with the specified requirements;
 - b) The sample is not damaged; and
 - c) The sample is not required to be retained under any other provision of the Contract.
- 40.2.8** Additional samples shall be provided for testing, if in the opinion of the Engineer:
- a) Material previously tested no longer complies with the specified requirements; or
 - b) Material has been handled or stored in such a manner that it may not comply with the specified requirements; or
 - c) The Employer, the Azerbaijan authorities or the applicable legislation in Azerbaijan could require it.

40.3 TESTING

- 40.3.1** The Contractor shall be responsible for all on-site and off-site testing and for all in-situ testing.
- 40.3.2** All appropriate laboratory tests shall be carried out in the laboratory provided by the Contractor, unless otherwise permitted or required by the Engineer.
- 40.3.3** Where the laboratory is not appropriately equipped and/or staffed for some tests, or if agreed to by the Engineer, tests may be carried out in other laboratories provided that:
- a) They are accredited for the relevant work to a standard acceptable to the Engineer; and
 - b) Particulars of the proposed laboratory are submitted to the Engineer for his consent.
- 40.3.4** Tests repeat shall be done in following cases:
- a) The Employer or Azerbaijan authorities bring the test results or laboratory or the established certificates in question;
 - b) If the tests are implemented in another country and not witnessed by the Employer/Engineer and/or the laboratory has not provided adequate certification to demonstrate that they are a Nationally Certified Testing Facility for that country.
- 40.3.5** On-site tests shall, if required, be carried out in the presence of the Engineer.

- 40.3.6** The Contractor shall provide the opportunity for two personnel from the Employer/Engineer to participate in the tests, with all costs for transport, accommodation, meals at the Contractor's amount.
- 40.3.7** Equipment, apparatus and materials for in-situ tests and laboratory compliance tests carried out by the Contractor shall be provided by the Contractor, the equipment and apparatus shall be maintained by the Contractor and shall be calibrated before the testing starts and at regular intervals as permitted by the Engineer.
- 40.3.8** The Contractor shall be entitled in all cases to attend any testing carried out in the Employer's or other laboratories, to inspect the calibration certificates of the testing machines and to undertake the testing on counterpart samples.
- 40.3.9** Attendance at tests, including that by the Engineer, Contractor and Designer, shall be as laid down in the Quality Assurance procedures.
- 40.3.10** A reputable independent and certified international laboratory shall be proposed by the Contractor for approval by the Engineer and once approval is gained, engaged by the Contractor for checking and certifying for quality of all material and parts to be used in the Works.

40.4 COMPLIANCE OF BATCH

- 40.4.1** The results of tests on samples or specimens shall be considered to represent the whole batch from which the sample was taken.
- 40.4.2** A batch shall be considered as complying with the specified requirements for a material if the results of specific tests for the specified properties comply with the specified requirements for the properties.

40.5 RECORDS OF TESTS

- 40.5.1** Records of in-situ tests and laboratory compliance tests carried out by the Contractor shall be kept by the Contractor on the Site and a report shall be submitted to the Engineer within the time stated in the Contract or in the Quality Assurance Programme, after completion of each test. In addition to any other requirements, the report shall contain the following details:
- a) Material or part of the Works tested;
 - b) Location of the batch from which the samples were taken or location of the part of the Works;
 - c) Place of testing;
 - d) Date and time of tests;
 - e) Weather conditions in the case of in-situ tests;
 - f) Technical personnel supervising or carrying out the tests;
 - g) Size and description of samples and specimens;
 - h) Method of sampling;
 - i) Properties tested;
 - j) Method of testing;
 - k) Readings and measurements taken during the tests;
 - l) Test results, including any calculations and graphs;
 - m) Specified acceptance criteria; and
 - n) Other details stated in the Contract.

40.5.2 Reports of tests shall be signed by the Contractor's Representative or his delegate, or by another representative authorised by the Contractor.

40.5.3 Records of tests carried out by the Employer's staff or by the Engineer shall be given to the Contractor.

41 RECORDS

41.1 DOCUMENTS PRODUCED BY THE CONTRACTOR

41.1.1 Documents and drawings produced by the Contractor including drawings of site layouts, Temporary Works, etc. for submission to the Engineer shall generally be to ISO A1 size.

41.1.2 Documents and drawings shall display a title block with the information as detailed in Appendix 7.

41.1.3 The drawings shall be also prepared in accordance with the applicable legislation in Azerbaijan and shall show the names of the Contractor and the Employer.

41.1.4 The number of copies to be submitted to the Engineer shall be one (1) soft copy, three (3) bound copies, or such other number of copies as required by Engineer, and sufficient copies (soft and hard) as the Contractor shall be required to provide for the approving authorities in Azerbaijan.

41.1.5 The drawings shall be prepared in English and Azeri and the hard copies shall be attached with their electronic version.

41.2 PROGRESS PHOTOGRAPHS & VIDEOS

41.2.1 The Contractor shall provide monthly progress photographs and videos (max 2 minutes each in length) which have been properly recorded to show the progress of the Works to the Engineer.

41.2.2 The photographs, of not less than 72 in number, and video, of not less than two (2) in number, shall be taken at locations agreed with the Engineer to record the exact progress of the Works.

41.2.3 Two sets of photographs and the videos shall be provided on CD-ROM format; one set of photographs shall be submitted to the Employer.

41.2.4 The Contractor shall ensure that no photography is permitted on the Site without the agreement of the Engineer and Employer.

41.3 RECORDS OF WAGE RATES

The Contractor shall keep monthly records of the average, high and low wage rates for each trade / tradesman / labourer employed on the Site and records shall be made available to the Engineer for inspection.

42 MATERIALS

42.1 GENERAL

- 42.1.1** Materials and goods for inclusion in the Permanent Works shall be new. Earthworks material that is not contaminated with hydrocarbons or other unwanted chemicals, can be recycled and re-blended material as approved by the Engineer.
- 42.1.2** The materials other than the rail components, shall be considered as new if they are manufactured not more than one (1) year before the date of installation and their warranty period shall cover the Defects Notification Period.
- 42.1.3** All track work products, e.g. Rail, fastening system, sleeper, insulated rail joints and other track components shall all have a defect warranty period that extends to the end of the Defects Notification Period, such warranty to be provided by the manufacturer and/or the Contractor on behalf of the manufacturer.
- 42.1.4** Preference shall be given to locally produced and manufactured materials where available.
- 42.1.5** Certificates of tests by manufacturers which are required to be submitted to the Engineer shall be current and shall relate to the batch of material delivered to the Site.
- 42.1.6** Certified true copies of certificates may be submitted if the original certificates could not be obtained from the manufacturer.
- 42.1.7** Materials which are specified by means of trade or proprietary names may be substituted by materials from a different manufacturer who is approved by the Engineer provided that the materials are of the same or better quality and comply with the specified requirements.
- 42.1.8** Samples of materials submitted to the Engineer for approval shall be kept on the Site and shall not be returned to the Contractor or used in the Permanent Works unless permitted by the Engineer.
- 42.1.9** Materials delivered to the Site for use in the Permanent Works shall be of the same or better quality than the approved samples.
- 42.1.10** All materials, equipment and service to be supplied under the contract shall have their origin in accordance with Section 5 Eligible Countries, of the Bidding Document.

42.2 PROVISION AND DISPOSAL OF EARTHWORKS MATERIAL

- 42.2.1** The Contractor shall be responsible for the provision and disposal of all classes of earthworks material required for the Works, including the earthwork or ballast materials obtained from the dismantling of the old line, and for new material whether sourced from excavations within the Site or obtained from any other sources, which are located outside the Site.
- 42.2.2** The earthworks material won from the existing track, after being tested and found to be not contaminated, can be recycled by re-grading and blending and returned as new track materials, as approved by the Engineer.

All returned materials shall not be contaminated with grease, oil or other hydrocarbons, or other unacceptable chemicals. Any materials contaminated with hydrocarbons or other chemicals exceeding the MENR requirements shall be disposed at approved locations off-site.

- 42.2.3 The Contractor shall arrange for all permits/approvals, permissions and fees for the areas needed for winning material in accordance with his Works Plan, and shall be responsible for all necessary permits/approvals to be obtained from the relevant Azerbaijan authorities for all such areas that might be needed during the Contract for temporary or permanent use.
- 42.2.4 The Contractor shall not use any territory owned by the Employer for provision and disposal of any materials, without pre-approval of the Engineer.
- 42.2.5 The Contractor shall prepare a Waste Management Plan for approval by the Engineer and Employer as well as local authorities for all waste expected to be generated from construction of the Works. The Waste Management Plan will include details of tests, and frequencies of tests to be undertaken on materials to determine where those materials can be deposited. The materials include all earthworks, ballast and sub-ballast/formation material to be excavated from the existing track, as well as unwanted track works material that will be generated during the construction of the Works.
- 42.2.6 The Contractor shall regularly test material that is taken from the existing track in accordance with the Waste Management Plan to test for hydrocarbons and other pollutants to determine where the material can be disposed of or whether it can be re-used. Records of all tests shall be maintained for audit by the Engineer and other Authorities. If the material has pollutants in excess of the levels established by MENR (and/or other relevant Authorities), the material that is found to be contaminated shall be disposed of at off-site locations defined by the Authorities. The cost of testing, reporting, cartage and disposal including dumping fees shall be to the Contractor's account.
- 42.2.7 For fill or dumping sites for the excavated material, the Contractor shall prepare a land plan with details of surface drainage requirements, final formation levels, spreading and compaction of the fill during dumping, all acceptable to the Engineer. The Contractor shall also provide security for such sites, the dumping sites to be used by the Contractor shall be as approved by the Engineer.
- 42.2.8 All excavated material, excluding any waste or contaminated material, can be disposed of within the ADY right-of-way in locations agreed between the Engineer and the Contractor, or off-site at locations agreed by the Contractor with the relevant authorities.
- 42.2.9 All excavated material from the existing track that is suitable for disposal on ADY right-of-way shall be placed, suitably compacted and arranged as agreed by the Engineer.
- 42.2.10 All material for the new track construction shall be placed and compacted in accordance with the Employer's Requirements.
- 42.2.11 After the completion of each construction stage the Contractor shall make good the appointed disposal sites by levelling and spreading the fill so that it conforms with the landform, and shall then vegetate the area with grasses (seeding and turf) and plants (seedlings and shrubs/trees) native to Azerbaijan.

42.2.12 Material to be disposed of off-site shall be done so only at the appointed and approved site. All excavated material to be disposed of off-site shall be disposed at disposal dumps (areas) in accordance with the requirements of the relevant authorities and the Republic of Azerbaijan law in force.

42.2.13 The Contractor shall undertake the necessary steps and arrange for such disposal areas and obtain the required permits for the approval of the Engineer. All cartage and disposal shall be to the Contractor's account.

43 PROVISIONS FOR INTERFACING PARTIES

43.1 The Contractor shall prepare and keep up-to-date, an Interface Management Plan that shall be comprehensive and efficient, should satisfy all interfacing parties and be prepared in accordance with each interfacing party's implementation programs, and shall be approved by the Engineer.

43.2 The Contractor shall carry out all civil, structural and building works as specified in the contract for the Interfacing Parties, in particular any cable troughing required by the interfacing signalling contractor and as agreed by the Engineer.

43.3 These works shall include but not be limited to forming holes, casting plinths, trenches, casting-in components, forming holes in pre-cast elements and provision (and installation) of insulated rail joints, and other requirements.

43.4 The Contractor shall make all reasonable provisions to accommodate the fastenings and fixings of the Interfacing Parties, such provisions will be notified by the interfacing parties during the Working Drawing interface.

43.5 The Contractor shall provide attendance (which shall include but not be limited to electric lighting to a standard which shall facilitate the safe working of the Interfacing Party) on interfacing parties when they are working within areas of the Site handed over to the Contractor.

43.6 The details, scope and extent of such attendance are to be agreed between the Contractor and each Interfacing Party before the Installation Interfacing and Co-ordination Period.

43.7 In the event of the Contractor and the interfacing parties failing to agree on the details, scope and extent of attendance, then the Engineer shall proceed in accordance with the provisions of Sub-Clause 4.6 of the Conditions of Contract.

43.8 The above applies to the interface between different sub-contractors or two or more Contractors at one site.

44 RESTORATION OF AREAS DISTURBED BY CONSTRUCTION

44.1 Unless otherwise directed by the Engineer, any areas disturbed by the construction activity, either inside or outside the Project Right of Way, shall be reinstated as follows:

- (a) All areas affected by the construction work shall be reinstated to their original condition, with new materials, including but not necessarily limited to footpaths, parking lots, access roads, adjacent roads properties and landscaping.

(b) Grass cover shall be provided for any bare earth surface areas, along with proper provisions for surface drainage.

44.2 Landscaping drawings must be prepared and submitted by the Contractor to the Engineer and to the relevant authorities and the details shown must match the areas adjacent to the site.

45 EMPLOYER'S EQUIPMENT AND FREE-ISSUE MATERIALS

45.1 FREE-ISSUE MATERIAL

- 45.1.1 The Contractor may use free-issue material provided by the Employer from material and equipment arising from the dismantling of the Works.
- 45.1.2 Regarding the rails re-used for track N° 3 & 4, the Contractor shall agree the used R-65 R260 grade rail and locations with the Engineer;
- 45.1.3 Any dismantled or free-issue materials to be incorporated in the Works for permanent or temporary use, including for temporary signalling and telecommunication systems, shall be documented and certified by the Contractor in accordance with Azerbaijan legislation and ADY requirements and regulations.

45.2 DISMANTLED MATERIALS

- 45.2.1 In the course of undertaking the Works and at the Taking-Over of the Works, the Contractor will remove from the Site all dismantled and demolished materials, and free-issue materials not incorporated in the Works, and return these to storage at locations as indicated by the Employer (In case of debris or earthworks materials these shall be transported to the appropriate dump site areas as described above).
- 45.2.2 The dismantled materials shall be cleaned of debris prior to delivering to the Employer's/ADY storage location.
- 45.2.3 The Contractor shall receive a receipt from the Employer's/ADY store attendant for all dismantled materials returned to the Employer's/ADY store. The aggregate of the materials mentioned on the receipt and the aggregate of dismantled materials must tally correctly.
- 45.2.4 The costs for all the following works shall be to the Contractor's account:
 - i. The Contractor shall deliver during the period of the execution of the Works, in accordance with a schedule agreed by the Employer and approved by the Engineer, any re-usable material demolished, cleaned and removed from the works to the Employer's storage areas.
 - ii. The Contractor will submit his schedule of materials for delivery to the Engineer in sufficient time for the Employer to make necessary arrangements for storage.
 - iii. All demolished materials except for earthworks materials shall be evaluated for re-use by the Employer and approved by the Engineer.
 - iv. Those suitable for second-hand use shall be cleaned, sorted, transported and stored in accordance with the requirements for storage of such materials at places and in areas defined by the Employer.
 - v. The following dismantled materials shall be delivered by the Contractor to the Employer's storage areas after the procedures as described above:

- a) Rails – stacked in an orderly manner with the head of rail up, and steel dunnage. Special care to be taken to avoid loss of straightness during all handling, stacking and transport operations. A minimum two-point-slinging shall be used. More slings should be used for longer rails to prevent bending the rail.
 - b) Track Fastenings – placed in barrels;
 - c) Sleepers – neatly stacked with timber dunnage;
 - d) Turnouts – marked with type and angle, bundled, tied and stacked;
 - e) Any other materials as required by the Employer and duly instructed by the Engineer.
- vi. Any materials from the list above that are found not suitable for second-hand use, shall be disposed of by the Contractor as follows:
- a) Rails, track fastenings, turnouts, structures and any other metal parts shall be sorted, cleaned, transported, stored and submitted to the Employer at places and in areas defined by the Employer;
 - b) Timber sleepers for track and for turnouts (Track Siding only), as well as for railway bridges shall sorted, transported, stored and submitted to the Employer at places and in areas defined by the Employer;
 - c) Reinforced concrete sleepers and any other reinforced concrete elements from structures and buildings shall be demolished and the reinforcement steel shall be sorted, transported, stored and submitted to the Employer in the form of scrap at places and in areas defined by the Employer, while the concrete debris shall be treated as waste materials and disposed of by the Contractor at dump areas in according with the conditions of Contract.
- vii. The recovered ballast from the dismantled old line shall be cleaned and if suitable for use as track ballast and it meets shape and grading requirements, the recovered ballast can be re-used. If the recovered ballast is not suitable it shall be disposed of on ADY RoW at the discretion of the Engineer or disposed of off Site if contaminated.
- viii. The quality of the cleaned ballast shall be in accordance with the Azerbaijan National Standards and in accordance with ADY Regulations and EN 13450.
- ix. The dismantled signalling and telecommunication equipment, that is not going to be reinstalled by the Contractor or used as temporary signalling and telecommunication system, shall be transported, stored and submitted to the Employer by the Contractor to places and in areas defined by the Employer, the equipment may include, but not be limited to:
- a. (a) Signalling equipment including point machines, lever arms, locks, cables, signals and poles, signalling equipment in signal posts, etc.;
 - b. (b) Telecommunications equipment in station buildings, telecommunication poles, telecommunication overhead wires, etc.;
 - c. (c) Lighting parts, electric boards, etc.;
 - d. (d) Any other materials as required by the Employer and duly instructed by the Engineer,
- x. All materials, other than specified in this clause, shall be deemed to remain the responsibility of the Contractor and shall be removed off the site by him before the Taking-Over of the Work.

ATTACHMENT A

CONTRACTOR'S LABOUR CAMP

1 EMPLOYER SHALL NOT PROVIDE QUARTERS FOR CONTRACTOR'S LABOUR

(1) The Employer will not provide living accommodation for the use of the Contractor or any of his staff or labour employed on the Works.

2 PROVISION OF LABOUR CAMP

(1) The Contractor shall make adequate arrangements for the housing, supply of drinking water and provision of bathrooms, latrines and urinals, with adequate water supply, for his staff and workmen directly or through sub-contractors employed on the Works at the location authorised by

(2) The Contractor shall maintain all campsites in a clean and sanitary condition.

(3) The Contractor shall obey all health and sanitary rules and regulations and carry out at his cost all health and sanitary measures that may from time to time be prescribed by the State Ordinances and Regulations.

(4) The Contractor shall permit inspection of all health and sanitary arrangements at all times by the Employer, Engineer and the staff of the local municipality or other authorities concerned

(5) Should the Contractor fail to provide adequate health and sanitary arrangements these shall be provided by the Employer and the cost recovered from the Contractor.

(6) The Contractor shall provide First Aid and Medical facilities at the Labour Camp and at work sites in relation to the strength of the Contractor's staff and workmen, employed directly or through sub-contractors.

(7) The Contractor shall provide the following minimum fire precautions:

(a) Portable Fire Extinguishers;

(b) Manual Fire Alarms;

(c) Water Supply for use by the Fire Service.

(8) The Contractor shall provide necessary arrangements for keeping the camp area sufficiently lighted to avoid accidents to the workers.

(9) These installations shall be maintained, and daily maintenance records must be made available for inspection of the Engineer.

3 CAMP DISCIPLINE

(1) The Contractor shall take requisite precautions and use his best endeavours to prevent any riotous or unlawful behaviour by or amongst his workmen, and others, employed directly or through sub-contractors, these precautions shall be for the preservation of the peace and protection of the inhabitants and security property in the neighbourhood of the Works.

(2) No alcoholic drinks or other intoxicating drugs or beverages shall be sold upon the site, in any labour camp, or in any buildings or encampments owned or occupied by, or within the control of the Contractor or any of his employees employed on the work, the Contractor shall exercise his influence and authority to secure strict compliance with this condition and the Contractor shall also ensure that labour or employees do not work at the site in an intoxicated state or under the influence of drugs.

(3) The Contractor shall ensure that persons not involved in the project are not present at the site, in any labour camp, or in any buildings or encampments owned or occupied by, or within the control of the Contractor or any of his employees employed on the work.

4 LABOUR ACCOMMODATION

(1) The Contractor shall provide living accommodation that is equal to or exceeds the minimum criteria established in the following sub-sections, needed to house his staff, workers employed directly or

through sub-contractors, the buildings shall be constructed so as to have a minimum life of not less than the length of the Contract.

(a) The roofs shall be watertight and laid with suitable non-flammable materials permissible for residential use under local regulations and for which the consent of the Engineer has been obtained.

(b) Each house shall have suitable ventilation, all doors, windows, and ventilators shall be provided with security leaves and fasteners.

(c) Back to back units may be avoided.

(d) The minimum height of each unit shall be 2.60m and shall have separate cooking facilities.

(e) Suitable numbers of toilets/washing facilities shall be provided.

5 DRAINAGE

(1) The Contractor shall provide arrangements for draining away sewage water to keep the camp neat and tidy.

(2) Surface water shall be drained away from paths and roads and shall not be allowed to accumulate into ditches or ponds.

6 SANITATION

6.1 The Contractor shall decide for conservancy and sanitation in the labour camps according to the rules and regulations of the Local Public Health and Medical Authorities.

6.2 The Contractor shall provide a sewage system that is adequate for the number of residents in the camp, and which meets the requirements of the Municipal Authorities.

PART 5

**TECHNICAL SPECIFICATION -
MANUFACTURE, SUPPLY, INSTALLATION,
TESTING & COMMISSIONING
AND TRAINING**

1 INTRODUCTION

- 1.1 These Employer's Requirements establish the overall procedures for the Contractor to follow for the work that is related to the Track and Civil;
- 1.2 These requirements relate to manufacturing, procurement and delivery of plant and equipment and the requirements for installation, testing and commissioning, and associated activities (manuals, spares, training etc.).
- 1.3 The Contractor shall inform the Employer for the commissioning of the manufactured parts at the manufacturer.
- 1.4 The Employer and the Engineer shall be able to participate at the tests of the batches before the material is supplied to the site, in particular for rails, sleepers/fastenings, ballast, insulated rail joints and/or glued insulated rail joints and the turnouts with components, electric and/or alumino-thermic welds.
- 1.5 The Contractor shall organize those participations as required at his account.
- 1.6 A batch shall be considered each group of materials sent with one run.
- 1.7 The materials delivered to the site shall be manufactured not more than 1 year before the date of installation and their warranty period shall cover the Defects Notification Period.
- 1.8 The leading standards for the materials shall be the ADY standards and GOST, SNIP standards, the other eligible standards are UIC, BDS, BS, DIN, ASTM and EN, in accordance with the country of manufacture.
- 1.9 Other international standards may be used if it can be proven that they are equivalent or of a higher level to the above standards.
- 1.10 All standards, norms, regulations etc. should be approved by the relevant Azerbaijan authorities.
- 1.11 Those sections relating to the relevant material shall be translated by the Contractor into Azeri.
- 1.12 The Contractor shall obtain approvals for the software, materials and measuring devices by the relevant Azerbaijan authorities before implementing the tests.
- 1.13 If such approvals are not obtained the Contractor shall change the material with approved in Azerbaijan equivalent at his account.

2 GENERAL

- 2.1 The Contractor shall establish a plan for Manufacture, Supply, Installation, which defines the procedures and controls that govern the procurement, integration, manufacture, quality assurance and delivery of plant, equipment and spares to be supplied under the Contract within one (1) months of the Date of Commencement.
- 2.2 The Contractor shall separately provide within two (2) months of the Date of Commencement, a comprehensive Testing and Commissioning Plan for the Works.
- 2.3 These Plans shall include the administration and supply of spare parts and warranties in accordance with the Contract and be submitted to the Engineer for his review and approval.

3 PROCUREMENT AND SUB-CONTRACT MANAGEMENT

- 3.1 The Contractor shall prepare and implement a Quality Assurance Plan based on ISO 9000-2015 standards addressing each element therein for the management systems and procedures for materials procurement and sub-contracting, sufficient to assure technical, administrative, quality and contractual controls consistent with those of this contract.
- 3.2 The Contractor's management system shall be auditable for material sources, lot numbers, serialised equipment, etc., sub-contract amendments shall be employed whenever contractual changes are made either bi-Laterally or unilaterally by the parties involved.
- 3.3 Registration of the Contractor's organisation, or sub-contractors or sub-consultants is not required for this Project but the Project Quality Management Plan, as submitted, shall meet the intent of the ISO 9000-2015 requirement in that there is a comprehensive and documented approach to achieving the project quality requirements.

4 MANUFACTURING AND PRODUCTION MANAGEMENT

- 4.1 The Contractor shall submit manufacturing data as part of the Manufacturing Management Plan, and this shall contain:
 - a) Material data sheets;
 - b) Brief description of all inspection holds points and test points, and a correlation with the Programme Schedule;
 - c) List of all sub-contractors; and
 - d) Shipping and delivery schedule of each item of equipment to match the installation plan.

5 TESTING PROGRAMME

- 5.1 The Contractor shall provide a comprehensive testing programme that shall include the complete equipment, their sub-systems, components and material to assure conformance with the Specifications.
- 5.2 The testing programme shall be approved by the Engineer.
- 5.3 The purpose of the comprehensive testing programme shall be to:
 - a) Substantiate design where specified under the Contract and performance characteristics;
 - b) Ensure operational compatibility;
 - c) Complete equipment verification and acceptance requirements; and
 - d) Complete all reliability, maintainability and safety demonstration requirements.

6 INSPECTION BY THE ENGINEER AND EMPLOYER'S PERSONNEL

- 6.1 The Contractor shall prepare an Inspection Programme for agreement by the Engineer which shall provide the opportunity for the Engineer and the Employer's Personnel to have access at key points during the production and manufacture of Materials and Plant to examine, inspect, measure, and test the materials and workmanship, and check progress, as necessary.
- 6.2 Where such an inspection takes place on completion of production or manufacture this may be combined with the Testing Programme referred to in this document.

7 QUALITY ASSURANCE AND CONTROLS

- 7.1 The Contractor's management systems shall emphasise quality assurance and controls and shall be based on ISO 9000-2015 standards.
- 7.2 The programme shall ensure an acceptable level of quality for the equipment supplied.
- 7.3 The concept of total quality assurance shall be based on the principle that quality is a basic responsibility of the Contractor's organisation, and shall be evidenced by:
 - a) Producable and auditable designs;

- b) Procurement and job performance specifications;
 - c) Procedures for transmission of information and data to sub-Contractors and for ensuring their compliance;
 - d) Testing to ensure repetitive product conformity to design requirements; and
 - e) Total programme of surveillance and verification of physical performance and configuration accountability.
 - f) Adequate records shall be kept by the Contractor to provide evidence of quality and accountability, these records shall include results of inspections, tests, process controls, certification of processes and personnel, discrepant material; and other quality control requirements.
- 7.4 Inspection and testing records shall, as a minimum indicate the nature of the observations made, and the number and types of deficiencies found, and action proposed to correct deficiencies.
- 7.5 Records for monitoring work performance and for inspecting and testing shall indicate the correction of deficiencies.
- 7.6 The Contractor shall submit to the Engineer a request for a "Notice of No Objection to Supply" for all manufactured items prior to shipping, this shall be accompanied by a Verification Submission which shall provide sufficient documentary demonstration of the suitability of the Plant and Materials for supply and shall include but not be limited to the items (a), (b) and (c) contained in Clause 10 below.
- 7.7 Such Notice of No Objection may be issued by the Engineer in respect of the completion of Manufacturing of a major and distinctive element comprising part of the Permanent Works. However, supply shall not be commenced until the original copies of the appropriate Submission have been endorsed:
- a) By the Contractor as "Goods for Supply";
 - b) By the Engineer that he has no objections to the supply.
- 7.8 In addition, the Contractor shall comply with **Appendix 6** and the "Quality Management" requirements stated elsewhere in this document.

8 SHIPPING

- 8.1 The Contractor's Manufacturing Management Plan shall provide for the proper inspection of equipment to ensure satisfactory completion of manufacturing and testing / check prior to shipment.
- 8.2 All shipments shall be adequately protected to preclude damage during shipment.
- 8.3 The Contractor's quality control personnel shall verify the inspection and preparation for shipment.

9 HANDLING, STORAGE AND DELIVERY

- 9.1 The Contractor's Manufacturing Management Plan shall provide for adequate work and inspection instructions for handling, shipping, storage, preserving, packaging, packing, marking, and shipping to protect the quality of the equipment and to prevent damage, loss, deterioration, degradation or substitution thereof.
- 9.2 Handling procedures shall include the use of special crates, boxes, containers, transportation vehicles, equipment and facilities for materials handling.
- 9.3 Means shall be provided for protection against deterioration or damage to equipment in storage. Where shelf life of the equipment is limited this shall be clearly stated on the shipment. Secure compounds for high value items shall be provided.

10 'MANUFACTURE & SUPPLY' VERIFICATION SUBMISSION

- 10.1 On completion of the manufacture of Plant, the production of Materials, and the associated testing, and Quality Assurance and Control processes, a 'Manufacture & Supply' Verification Submission shall be prepared which shall provide sufficient documentary demonstration of

the suitability of the Plant and Materials for subsequent installation, this shall include, but not be limited to:

- a) confirmation that the manufactured items of Plant or Materials produced fully comply with the Working Drawings relating to manufacture;
 - b) confirmation that all relevant testing has been successfully completed, with supporting completed test documentation;
 - c) confirmation that all Quality Assurance and Controls processes have been completed with the required level of satisfaction, with supporting completed Quality Assurance documentation;
 - d) confirmation that the Plant and/or Materials have not suffered damage or deterioration during transit to site.
- 10.2 The Contractor shall not commence the subsequent Installation phase until he has received a Notice of No Objection from the Engineer in respect of the Manufacture & Supply Verification Submission.
- 10.3 Such Notice of No Objection may be issued by the Engineer in respect of completion of the manufacturing and supply of a major and distinctive element comprising part of the Permanent Works.

11 INSTALLATION REQUIREMENTS

11.1 INSTALLATION PLAN AND PROGRAMME

- 11.1.1 The Installation Plan shall show how the Contractor proposes to organise and carry out the Installation and complete the whole of the Works by the given Key Dates.
- 11.1.2 The Contractor shall submit the Plan for the review of the Engineer 90 days prior to the start of Installation on-site.

11.2 INSTALLATION METHOD STATEMENT

- 11.2.1 Installation Method Statements shall be submitted to the Engineer for review at least 30 days prior to the installation activity commencing On-Site, this shall show in particular the loadings and modes and delivery routes of the items of equipment.
- 11.2.2 Prior to proceeding with installation, the Contractor shall submit for the Engineers consent six (6) copies of drawings showing all installations including dimensions, supports, installation methods and documents confirming the availability and location of special installation tools and equipment and all other pertinent data.
- 11.2.3 The Contractor shall make certain that the installation of all material are accomplished to assure safe, accurate and trouble-free installation.
- 11.2.4 Equipment that is improperly installed shall be removed, checked / tested and reinstalled. Any damage caused due to improper installation and removal shall be rectified before reinstallation.

12 TESTING AND COMMISSIONING

12.1 GENERAL

Track Work commissioning is the process whereby the Contractor demonstrates and confirms, through a series of tests, inspections and observations, that the Works meets the requirement of the Contract, in order to demonstrate that it is fit for purpose and it will perform as intended, both independently and in conjunction with other systems, when put into service.

- 12.1.1 The Contractor shall perform all test procedures applicable to the system and shall conduct factory acceptance tests, first article acceptance tests, site installation and acceptance tests.
- 12.1.2 Testing shall be undertaken generally in accordance with the requirements contained within relevant clauses of the latest version of standards relating to the particular

equipment concerned, together with other relevant standards which relate specifically to testing. The order of precedence for Standards is set out in **Appendix 16**.

- 12.1.3 The commissioning activity shall include a period of Integrated System Testing followed by a period of Test Running for staff training and familiarisation and timetable proving purposes.
- 12.1.4 The Contractor shall note that ADY Freight Dept. Representatives will inspect the Works from time to time for determining whether the operating railway complies in terms of operational and infrastructure safety in accordance with the laws of Azerbaijan.
- 12.1.5 The Contractor shall note that the State Agency for Control over Construction Safety "GOST expertise" under the Ministry of Emergency Situations of Azerbaijan Republic approval may be mandatory for commissioning the system.
- 12.1.6 Notwithstanding any other provisions of the Contract, the Contractor shall ensure that the Works comply with the requirements of ADY in terms of operability.
- 12.1.7 The Contractor shall assist the representatives of ADY and other relevant governmental bodies in carrying out their inspection duties and also comply with their instructions regarding rectifying any defects and making good any deficiencies.
- 12.1.8 Prior to commissioning the State Agency for Control over Construction Safety "GOST expertise" under the Ministry of Emergency Situations of Azerbaijan Republic may inspect and authorise the putting into service of the equipment.
- 12.1.9 The Contractor will allow for inspection for authorisation of commissioning of the railway by the committee and will comply with any requirements issued for rectifying any defects and making good any deficiencies.

12.2 TEST PROGRAMMES AND PROCEDURES

- 12.2.1 The Contractor shall propose within six (6) months of the Date of Commencement for approval by the Engineer, his procedures and tests required for commissioning the Works and provide a Testing and Commissioning Plan which shall contain the following information:
 - 12.2.2 Overall test strategy from sub-system to system and integration into the overall Works;
 - 12.2.3 Roles and responsibilities for the execution of testing along with curriculum vitae and certification for staff testing safety critical systems;
 - 12.2.4 Preliminary schedule of tests, details of tests with outcome parameters, test locations, and proposed dates for all system and components tests;
 - 12.2.5 A schedule of test documentation that the Contractor will produce as a record of the testing undertaken and results obtained.
 - 12.2.6 Unless agreed in writing by the Engineer, personnel engaged by the Contractor for testing shall be independent of those directly engaged in the design or installation of the same equipment.
 - 12.2.7 All Test equipment shall carry an appropriate and valid calibration label. They shall be periodically checked for calibration accuracy.
 - 12.2.8 The Contractor shall sign all Test Reports.
 - 12.2.9 All Test procedures shall be submitted at least thirty (30) days prior to conducting any Test.
 - 12.2.10 Test procedures shall show the extent of testing covered by each submission, the method of testing, Acceptance Criteria, the relevant drawing (or modification) status, and the location.
 - 12.2.11 Test Procedures shall be amended, as required, by the Contractor during the currency of the contract to reflect changes in system design or the identification of additional testing requirements.
 - 12.2.12 The Employer, the Engineer and/or any of their staff shall have the facility to monitor all Tests and have access to all Test records.

- 12.2.13 Ample time shall be allowed within the testing programmes for necessary alterations to equipment, systems and designs to be undertaken, together with re-testing prior to final commissioning.
- 12.2.14 The Contractor is reminded that the Works are to be undertaken with the electric traction system energised, if not from time to time explicitly agreed otherwise for sectional or temporary Track Possessions, and that additional precautions for the safety of staff and co-ordination of activities during "power-on" shall be anticipated in his installation, testing and commissioning programmes.
- 12.2.15 Three (3) months before Testing and Commissioning is due to commence for any Section, a Testing and Commissioning Programme is to be prepared by the Contractor for the Engineer's approval. The programme shall include:
- a) Full details of the contents and sequences for all tests to be carried out;
 - b) The procedures, standards or limits to be achieved for each test including verification and validation;
 - c) The Testing and Commissioning Programme shall then be updated monthly (as a minimum) for control and monitoring of the Contractor's progress.

12.3 MANUFACTURE & SUPPLY: SEQUENCE OF TESTS TO BE UNDERTAKEN

12.3.1 The sequence of tests shall comprise as appropriate the following:

- a) Type tests;
- b) First Article Inspection (FAI) tests
- c) Factory acceptance tests (FAT) or works test;
- d) Installation tests;
- e) Partial acceptance tests (PAT)
- f) Functional tests;
- g) Integration tests;
- h) Dynamic tests;
- i) System acceptance tests (SAT);
- j) Tests on Completion (integrated system tests);
- k) Tests after completion (test running).

12.3.2 TYPE TESTS

- 12.3.2.1 Should the Contractor propose to include any equipment not previously proven in railway service or of any modified design, the Contractor shall undertake thorough testing of pre-production units to the satisfaction of the Engineer.
- 12.3.2.2 The Contractor shall identify in his tender any equipment in this category, or equipment that differs significantly from that already in service elsewhere.
- 12.3.2.3 Type tests including prototype testing shall be performed prior to full production and before FAT.
- 12.3.2.4 Type testing shall be used to confirm that the proposed equipment complies with the design criteria specified and meets the requirements of the Contract.

12.3.3 FIRST ARTICLE INSPECTION TESTS

- 12.3.3.1 The Testing and Commissioning Plan shall list all major sub-systems and shall identify those that the Contractor proposes to be subject to First Article Inspection (FAI).
- 12.3.3.2 As a minimum this shall include:
- a) rail,
 - b) rail fastening system,
 - c) sleeper,
 - d) ballast, and
 - e) sub-ballast.

- 12.3.3.3 A maximum of three (3) persons from the Employer and Engineer shall accompany the Contractor for the FAI visits, the cost of which shall be to the Contractor's account.

12.3.4 WORKS TESTS

- 12.3.4.1 Works Tests shall include but not be limited to:
- a) Physical inspection;
 - b) Dimension check;
 - c) Electrical check;
 - d) Calibration;
 - e) Output check;
 - f) Operational performance;
 - g) Full Load test;
 - h) Insulation test;
 - i) Soak test (wooden sleepers/timbers);
 - j) Any other test required as per relevant standards or codes.
- 12.3.4.2 A Factory Test Plan shall be submitted for the Engineer's review within one (1) month from the Date for Commencement.
- 12.3.4.3 All materials, components, sub-assemblies, unit assemblies shall be subject to testing and certification.
- 12.3.4.4 Notification of these Tests shall be submitted to the Engineer thirty (30) days in advance of carrying out any Test, the Engineer will then determine which, if any, items that may be accepted based on previous supply or experience.
- 12.3.4.5 The FAT shall demonstrate that each sub-system and the System meet its functional specification.

12.4 INSTALLATION TESTS (AS APPLICABLE)

12.4.1 Prerequisites for Installation:

- a) Prior to installation, the Contractor shall ensure that equipment delivered to Site has not been damaged in transit and ensure for their dimension accuracy.
- b) Designs for the Sections under test shall be completed and submitted to the Engineer for review prior to Installation.

12.4.2 Inspection:

- a) The inspection shall verify that equipment has been installed to the procedures and design that have been reviewed without objection by the Engineer and that equipment is correctly located and labelled.
- b) The Contractor shall maintain inspection records to demonstrate that each item of equipment has been inspected and found to be satisfactory and attach to this record a detailed list of any discrepancies found and remedial work carried out.
- c) As defects are rectified, these shall be recorded on the appropriate inspection record.

12.4.3 Installation Tests

- 12.4.3.1 The Contractor shall carry out installation tests for each sub-system (e.g. turnouts) following Installation but before Functional Testing to demonstrate that the installation has been carried out correctly and equipment is properly housed and fixed.

12.4.4 Partial Acceptance Tests (PAT)

- 12.4.4.1 Installation work shall be completed, and inspection records submitted to the Engineer for review before the start of each PAT.

- 12.4.4.2 The PAT Plan shall be submitted for the Engineer's review at least four (4) months before the start of each PAT.

12.4.5 Functional Tests

- 12.4.5.1 The functional tests of the PAT shall be carried out on installed equipment before System Acceptance Tests (SAT) to demonstrate that portion of the Works operates correctly in accordance with the Specification.
- 12.4.5.2 The Functional Tests shall include track deflection tests in locations agreed with the Engineer, under various rolling loads up to 25 ton axle load to check and assure that the track deflection does not exceed the specification requirements.
- 12.4.5.3 The functional tests shall sequence through all required operations to prove that the System performs in accordance with the Specification and that the local configuration is correct.
- 12.4.5.4 Where necessary, input conditions shall be simulated.
- 12.4.5.5 The functional tests shall be specified and carried out by Contractor's personnel independent of design and installation.

12.4.6 Integration Tests

- 12.4.6.1 Partial Acceptance Test (PAT) shall include integration tests to integrate the various sub-systems of the System and demonstrate correct operation of all internal and external interfaces.
- 12.4.6.2 Following satisfactory completion of these Tests, the Contractor shall prepare the installation for formal demonstration in the presence of the Engineer.

12.4.7 System Acceptance Tests (SAT)

- 12.4.7.1 The Contractor shall prepare and organise a comprehensive programme of Tests to demonstrate to the Engineer that all systems defined under the Contract, when installed, connected and configured as a complete system meet the specified performance requirements in all respects.
- 12.4.7.2 Prerequisites and requirements for SAT to be satisfied before the start of the System Acceptance Tests (SAT) shall be as follows:
- i. All documentation for the System Safety Report shall be submitted to the Engineer for review;
 - ii. All PAT shall be completed, and test records submitted to the Engineer for review;
 - iii. Authority's staff shall be given a training course in the System as defined in the Section on Training herein;
 - iv. Facilities for the maintenance of the System shall be in place;
 - v. The SAT Plan shall be submitted to the Engineer for review at least one hundred and twenty (120) days before the start of the SAT.

12.5 INTEGRATED SYSTEM TESTS (Tests on Completion)

- 12.5.1 The Contractor shall submit to the Engineer requirements and procedures for Integrated System Tests being part of the Tests on Completion pursuant to Section 9 of the Conditions of Contract, in conjunction with interfacing contractors, including ADY, to demonstrate that the complete system comprising the Project is fully operational and meets the specified performance criteria.
- 12.5.2 The Contractor shall co-ordinate and liaise with the interfacing contractors to determine the scope and test outcomes required by all interfacing contractors prior to undertaking the integrated system tests.
- 12.5.3 The Contractor shall prepare an Integrated System Test Plan setting out all the tests, the responsible party for each test, methodology for the test, sequence of testing, test

result (outcome) required, and criteria for a Pass Grade for the Integrated System Tests, and present to the Engineer for review and approval prior to the Integrated System Tests commencing.

12.5.4 The Engineer shall be present for all testing to verify and validate the test results.

12.5.5 The conduct of these Integrated System Tests shall include a period of Trial Operation.

12.6 TEST RUNNING (TESTS ON COMPLETION)

12.6.1 Following satisfactory completion of the System Acceptance Tests and the Integrated System Tests the Employer will commence a period of Test Running to prove all technical systems in time table operation, to allow all technical systems to settle and to train staff in working procedures. Such tests shall be part of the Tests on Completion pursuant to Section 9 of the Conditions of Contract.

12.6.2 Test Running shall include:

- a) Two (2) passes at line speed by each of a passenger train (up to 16 tonne axle load) and a freight train loaded to 25 tonne axle load.
- b) Attendance by the Contractor for the whole of this period, which may be expected to include defect notification and repair activities and also further opportunity for technical staff training.

12.6.3 Attendance at the Test Running shall include the Employer, the Engineer and/or their authorised representative, and the Contractor.

12.7 SAMPLES FOR TESTING

12.7.1 Samples that have been tested may be incorporated in the Works provided that:

- a) the sample complies with the specified requirements;
- b) the sample is not damaged nor fatigued; and
- c) the sample is not required to be retained under any other provision of the Contract.

12.7.2 Additional samples shall be provided for testing if in the opinion of the Engineer:

- a) material previously tested no longer complies with the specified requirements; or
- b) material has been handled or stored in such manner that it may not comply with the specified requirements.

12.7.3 Unless agreed otherwise, all Tests shall be carried out by the Contractor in the presence of the Employer, the Engineer and/or their authorised representative.

12.7.4 Attendance at the Tests, including that by the Employer, the Engineer and/or their authorised representative, and the Contractor, shall be as laid down in the Quality Assurance procedures.

12.8 RECORDS OF TESTS

12.8.1 Records of Tests carried out shall be kept by the Contractor and a report and all Test results shall be submitted to the Engineer no later than 15 days after completion of the Test, in addition to any other requirements, the report shall contain the following details:

- a) Material or part of the Works tested;
- b) Location of the part of the Works;
- c) Place of testing;
- d) Date and time of tests;
- e) Technical personnel supervising or carrying out the tests;
- f) Equipment used and method of testing;
- g) Readings and measurements taken during the tests;
- h) Test results, including any calculations and graphs;
- i) Specified acceptance criteria;
- j) Other details stated in the Contract.

12.9 MAINTENANCE SUPPORT PLAN

- 12.9.1 The Contractor shall provide a Maintenance Support Plan in English and Azeri that shall include such items as:
- a) Procedures for maintaining each item, unit / equipment including routine survey, periodical overhaul and tests;
 - b) Maintenance strategies, including maintenance intervals for the track superstructure and preventive maintenance procedures;
 - c) Technical manuals;
 - d) Initial provision of spares, facilities, test equipment, tools, jigs and fixtures;
 - e) Training requirements;
 - f) Procedures for removal and replacement of components;
 - g) Periodic running of equipment and machines which would otherwise deteriorate because of non-operation for more than a week;
 - h) Manpower plan required for maintenance.
- 12.9.2 On completion of Test Running the Contractor shall deliver up to the Engineer copies of all manufacturing drawings, schedules and software- for all components, as well the As-Built Drawings.

13 MANUALS

- 13.1 The Contractor shall produce manuals for all equipment and systems supplied, these shall include, but may not necessarily be limited to, the following:
- a) System Manuals - a comprehensive description of all system principles at block diagram level;
 - b) Operating/User Manuals - broken into as many sub-sections as may be necessary and providing sufficient information to enable non-technical staff to exploit fully the facilities of each system;
 - c) Workshop Manuals – for example for the installation of CWR and incorporation of Turnouts, construction drawings and itemised parts list to enable all maintenance rectification and setting-up to be carried out;
 - d) Maintenance and Servicing Manuals - to specify requirements, procedures and servicing intervals for planned preventative maintenance and in addition to convey sufficient information on equipment principles and practice to enable first line fault diagnosis and rectification by technician staff.
- 13.2 The Systems and Operating/User Manuals and a summary (suitable for use at technician level) of the Maintenance and Servicing Manuals shall be prepared in both the English and Azeri languages. Other technical manuals shall be supplied in the Azeri language only.
- 13.3 The Contractor shall submit all Manuals for review by the Engineer prior to Factory Acceptance Tests.
- 13.4 The Contractor shall provide 6 controlled copies of all Manuals for the use of the Engineer.
- 13.5 The Contractor shall maintain all Manuals in an up-to-date condition throughout the Contract Period.

14 SPARES, SPECIAL TOOLS AND TEST EQUIPMENT

14.1 GENERAL

- 14.1.1 During the Defects Notification Period, the Contractor shall provide all materials including consumables, unit exchange spares and emergency spares required for maintenance of the track and structures constructed under this contract.
- 14.1.2 The Contractor may also be instructed to supply the spares, materials not later than 6 (six) weeks before the operation of the systems.

- 14.1.3 A list of such spares and materials required for maintenance during the Defects Notification Period shall be provided by the Contractor. The list shall be developed from recommendations by the various suppliers and presented to the Engineer for approval prior to the supply of the spares and materials.

14.2 PROVISION OF OPERATIONAL SPARE PARTS

- 14.2.1 The Contractor shall provide, after "SONO" of the Engineer, the following spare parts. These operational spare parts are to be supplied; stored; replaced, if used, during construction, commissioning or Defects Notification Period (DNP); and handed over to the Employer in full at the end of the DNP:

- i. 1000m of Rails type R-65, grade R260 with minimum length > 25m;
- ii. 1000m of Rails type R-65, grade R350HT with minimum length > 25m;
- iii. 100m of guard-rails for bridge sections including fastenings;
- iv. 10 sets of new R-65 fishplates including clamps (i.e. no rail bores)
- v. 2000 pcs standard line Pre-stressed Concrete Sleepers with Elastic Fastenings;
- vi. 100 sets of standard line fastenings systems;
- vii. 10 sets of Glued Rail Insulated Joint with minimum length = 12.5m;
- viii. Two (2) complete sets of turnouts elements for each type of turnout, including but not limited to stock rails, switch/tongue rails, closure rails, running rails, hardened cast manganese rigid crossing and check rails, setting and locking device, drive rods, and fastenings, all rail components with extended length of rail end parts to allow welding replacement, and all concrete bearers, plates and fastenings. (Note: A set of turnouts is one left hand and one right hand turnout. Hence 2 sets of 1:11R +2 sets of 1:11L)
- ix. Two (2) complete point machine sets complete with drive and locking device, and two motors (AC & DC) .

- 14.2.2 All spare parts shall be tested, shall be new and shall be defect free.

15 TOOLS AND TEST EQUIPMENT

- 15.1 The Contractor shall provide if instructed, six weeks before test and commissioning special tools and test equipment which are essential for day to day use in both corrective and preventative maintenance and for workshop use in the overhaul of all modules and units likely to be required over the full-service life of the installation.
- 15.2 The Contractor shall submit a schedule of all tools and equipment with details of calibration and supplier along with the tender.

16 SPARES LIST/SCHEDULE

- 16.1 The Contractor shall submit a schedule of anticipated contingency, emergency, routine maintenance and operational spare parts required for the track components for an initial operation period of 10 years. For each item of spares, its description, part number, the drawings, drawing number, labelling and storage, handling and mounting instruction.
- 16.2 This schedule shall include all types of consumable, unit exchange and emergency spares. The Contractor shall also advise the recommended inventory having regard to the lead time of the respective items.
- 16.3 The Contractor shall:
- a) Submit to the Engineer a list of spares required (divided into contingency, emergency, routine maintenance and operational spares), for the first 10 years of operation;
 - b) Base the spares calculations on the reliability and availability data and the criticality of the equipment;

- c) Identify the Original Equipment Manufacturer (OEM) as well as the Supplier (with contact details) for each of the spares;
- d) Submit to the Engineer for review the calculations and spares list;
- e) Submit to the Engineer a system for easy identification of spares.

16.4 The Spares list shall:

- a) Be grouped by track components, test equipment and special tools as applicable for stocking identification;
- b) Have detailed description with drawing references and correlation with the maintenance manuals.

16.5 Where the Contractor considers that any equipment that would be supplied, and which he considers cannot be economically or technically maintained by the Employer, then such items shall be identified, and proposals made for the maintenance of such equipment through OEM's (original equipment manufacturer).

16.6 SPARES: SECOND SOURCING

- 16.6.1 The Contractor shall identify principal and second-source suppliers that can supply the systems and sub-system spares listed.
- 16.6.2 The Contractor shall make the second-source supplier information, available to the Engineer at the time of submission of the Definitive Design.

16.7 SPARES: LONG LEAD TIMES

- 16.7.1 The Contractor shall identify the lead times for all spare parts.
- 16.7.2 Parts with long lead times shall be identified as such to the Engineer in the spares list.

16.8 SPARES: IDENTIFICATION AND CONFIGURATION CONTROL

- 16.8.1 All spare equipment identified on the spares list, shall conform to Identification and Configuration Control requirements established by the Contractor for the equipment provided under the Contract.

16.9 SPARES TESTING

- 16.9.1 The Contractor shall ensure that all spares are correctly calibrated, tested and labelled prior to their delivery.
- 16.9.2 Test certificates for each one of the equipment shall be submitted to the Engineer.

17 SHIPPING AND STORAGE OF EQUIPMENT AND MATERIALS

- 17.1 The Contractor shall be responsible to prepare, protect and store all equipment and materials to safeguard them against loss or damage from repeated handling, climatic influences and all other hazards arising during shipment or storage on or off the site.
- 17.2 All R-65 rail shall have a light oil protective coating applied to all parts to protect from corrosion.
- 17.3 The Contractor shall provide secure and covered storage for all equipment and materials except as otherwise agreed by the Engineer as being suitable for open storage.

17.4 CRATING

- 17.4.1 Each case, crate or package shall be of robust construction and suitable for the intended purpose. Packaging materials that are likely to suffer deterioration in quality as a result of exposure to environmental conditions likely to be met during transit from the factory of origin to the Site shall not be used.
- 17.4.2 The contents of each case, crate or package shall be protected against the harmful effects of ingress of water by enclosing within a heavy duty waterproof membrane and adding a suitable desiccant substance (e.g. silica gel) to the case, crate or package.

- 17.4.3 Each case, crate or package shall be legibly and indelibly marked in large letters with the address, Contract number, 'right way up', opening points and other markings like "fragile" etc. as necessary to permit materials to be readily identified and handled during transit and when received at Site.
- 17.4.4 Each case, crate or package shall contain a comprehensive packing list showing the number, mark, size, weight and contents together with any relevant Drawings.
- 17.4.5 A second copy of the packing list shall be enclosed in a watertight enclosure on the outside of each case, crate or package.
- 17.4.6 Distribution of additional copies of each packing list shall be in accordance with the requirements of the Engineer.
- 17.4.7 All items heavier than 100 kg shall be marked on the outside of the case to show the gross and net weights, the points for slinging and where the weight is bearing,
- 17.4.8 Care shall be taken to prevent movement of equipment within containers by the provision of bracing, straps and securing bolts as necessary.
- 17.4.9 Bags of loose items shall be packed in cases and shall be clearly identified by well-secured metal labels on which the quantity and name of the part and its index or catalogue number have been stamped.
- 17.4.10 Details of cases, crates, packages, containers, etc., intended to hold important or delicate items of equipment or materials shall be submitted to the Engineer for acceptance.

18 GENERAL PRECAUTIONS

- 18.1 Spare parts shall be suitably packed for storage over an indefinite period without deterioration and shall be clearly identified, showing full name and part number, without any need to unwrap packaging. Electrical and other delicate items or equipment shall be cocooned.
- 18.2 Cable ends, cable entry points into equipment and other similar terminations and openings shall be sealed or blanked off to prevent the ingress of dirt or moisture.
- 18.3 Tube ends, and other similar openings shall be thoroughly cleaned and then blanked off to prevent ingress of dirt or moisture.
- 18.4 Flanged ends shall be protected by adhesive tape or jointing material covered by a properly secured wooden blank not smaller than the flange itself.
- 18.5 Care shall be taken to prevent damage to, or corrosion of, shafts and journals where they rest on timber or other supports that may contain moisture.
- 18.6 At such points wrappings impregnated with anti-rusting compositions shall be used, of sufficient strength to resist chafing under the pressures and movements likely to occur in transit.
- 18.7 Care shall be taken to minimise risk of damage to ball and roller bearings and any fragile material in transit.

19 PACKAGING PROCEDURES

- 19.1 All Packaging procedures shall be submitted to the Engineer for acceptance.
- 19.2 The Contractor shall remove all empty cases, crates, or packages from the site within 1 month of their being emptied and dispose of them off-site.

20 EQUIPMENT IDENTIFICATION

- 20.1 All equipment and materials supplied shall be indelibly labelled or otherwise identified to show its identity, type, version, function, location, rating or limitation as appropriate.
- 20.2 Removable modules shall have the same indelible labelling on the fixture to which the module is attached. The label shall be adjacent to the module or prominently marked on the module and shall not be obscured.
- 20.3 Labels shall conform to a unified system and shall be to the requirements of the Engineer.
- 20.4 Where any hazardous situation could arise due to level, air pressure, maladjustment, mis-operation, etc., then prominent warning labels shall be provided to denote this.
- 20.5 In general, all labels shall be in both English and Azeri languages.

20.6 Where appropriate, such labels shall conform to accepted National or International Standards or as approved by the Engineer.

21 TRAINING AND TRAINING SUPPORT

21.1 TRAINING OBJECTIVES

- 21.1.1 The Contractor shall be required to arrange technology transfer to the Employer's staff in respect of design, manufacture, construction, hand-over, operations and maintenance of the plant and equipment provided under the Contract, these staff will include the Employer's management, operation, technical and instructional staff.
- 21.1.2 The Contractor shall train, or to arrange training for, the Employer's staff who shall be nominated by the Employer.
- 21.1.3 The Contractor shall train the Employer's staff in sufficient detail so that the staff can:
 - a) Appreciate, understand and monitor the technical, operational, maintenance, management and business aspects of the system;
 - b) Operate, maintain and manage the system efficiently and safely.
- 21.1.4 Of primary importance is the training of Employer's Training Staff, whose responsibility will be to provide support to the Training Instructors during the in-depth start-up training that will take place prior to and during initiation of test running.

21.2 MAIN TOPIC FOR TRAINING

- 21.2.1 The Contractor shall train the Employer's staff regarding:
 - a) The Installation and the Maintenance of the CWR (according to UIC 720 R), with special training regarding the neutralization method of the tension on the rail and the appropriate calculation (destressing), during the track installation and the maintenance period after track disturbance (broken rail), for example;
 - b) Welding (aluminium thermic, flash-butt and electronic arc) ultrasonic testing of welds;
 - c) Incorporation of the Turnouts in the CWR (EN 0291) and appropriate inspection and maintenance works with replacement of defective elements during the maintenance period;
 - d) Turnout operation and maintenance and adjustment of setting and locking device;
 - e) Fastening and sleeper control and replacement methods and procedures;
 - f) Tamping, ballast regulating, track stabilization, realignment, ballast cleaning methods and procedures;
 - g) Installation and maintenance of the Glued Insulated Rail Joint (GIRJ);
 - h) Rail grinding;
 - i) Asset Management Principles.

21.3 TRAINING PERIODS

- 21.3.1 The Contractor shall propose appropriate man-months of trainings to be provided, for each training subject in a consecutive series of three (3) trainings, one at design stage, one during construction stage and a final one during DNP.
- 21.3.2 All training courses will be conducted in English and in Azeri and the Contractor shall have available suitable training staff fluent in Azeri.
- 21.3.3 Where the courses are conducted in English the Contractor will provide a translation of the course and a full-time translator.
- 21.3.4 Training courses and training material shall be foreseen for up to 20 participants of each course of training subject and at each training stage.
- 21.3.5 Training courses shall cover a theoretical and a practical part and therefore at least over two days for each course of training subject and at each training stage.

21.4 TRAINING INSTRUCTORS

- 21.4.1 The training instructors provided by the Contractor shall be fully qualified and experienced track and infrastructure Engineers, who have a good knowledge of the English and Azeri language or have an interpreter available.

- 21.4.2 They will have had experience of training engineers or technicians of the level stated on similar topics or will be fully familiar with the equipment supplied or installed.
- 21.4.3 Before any of the Contractor's training instructors is appointed the Contractor shall submit detailed curriculum vitae for each training instructor for the approval of the Engineer.
- 21.4.4 Where the Employer's staff is attached to the Contractor (or his Sub-Contractors) for the purposes of training, all such trainees shall be properly supervised and monitored by a qualified training supervisor to ensure that each trainee has the best opportunity to benefit from the theoretical and practical experience.

21.5 TRAINING COURSES

- 21.5.1 The Contractor shall be responsible for the safety, health and welfare of trainees when under training.
- 21.5.2 Accordingly, an explanation of the safety rules and codes shall form part of a general induction course to be given by the Contractor and where considered necessary the Contractor shall issue a rule book for which the trainee shall sign indicating his acceptance and understanding thereof.
- 21.5.3 The training courses shall be programmed in phase with the progress of manufacture and installation to ensure that trainees are present during all stages of the manufacture, installation and commissioning of the Plant and Equipment that is the subject of the training.
- 21.5.4 The Contractor shall ensure that the courses fully encompass all aspects of the basic design, manufacture, installation, commissioning and maintenance of the Plant and Equipment with maximum effort being directed at instruction in the maintenance of the installations.
- 21.5.5 The training shall be structured in modular format; each module shall be capable of being delivered independently or together with other modules of a similar theme.
- 21.5.6 The Contractor shall provide a training plan that shall include as a minimum:
 - a) Schedule of training course;
 - b) Objectives;
 - c) Syllabus;
 - d) Format of course;
 - e) Training facilities required or to be provided;
 - f) List of training materials and documentation;
 - g) Examination procedures;
 - h) Training Instructors' qualifications; and
 - i) Course evaluation methods.
- 21.5.7 The Contractor shall make full and appropriate use of multi-media and computer techniques in the design and delivery of training packages, including all necessary teaching aids as well as technical literature, manuals, photographs, drawings, video and films, models and all other instructional materials as may be necessary for the training of the personnel.
- 21.5.8 Such materials, other than videos, films and reproducible materials prepared specifically for the trainees, shall be retained by the Contractor at the end of each training programme.
- 21.5.9 The Contractor shall provide all training material that shall include as a minimum:
 - a) Course agenda;
 - b) Objectives;
 - c) Lesson plans;
 - d) Outline presentations;
 - e) Equipment and software manuals;
 - f) Training aids including video film media; and
 - g) Computer-based training requirements.

21.6 TRAINING EQUIPMENT

- 21.6.1 In general, the Contractor shall use equipment specifically set aside for training purposes.
- 21.6.2 However, he may use, for the training of the Employer's staff, subject to the agreement of the Engineer, equipment being installed, tested or commissioned when no other such equipment is available.
- 21.6.3 The Contractor shall not use for this purpose spare parts from assemblies.
- 21.6.4 Any special or protective clothing required by the trainee shall be provided by the Contractor. Personal items of clothing shall be of new issue and may be retained by the trainee on completion of the training course.

21.7 MONITORING

- 21.7.1 Throughout the training programmes, the Employer and the Engineer shall have free access to all training sessions to monitor the progress of the trainees and the Contractor's training instructors.
- 21.7.2 To ascertain that the objectives of the courses have been achieved, the Contractor shall set periodical theoretical and practical tests for the trainees.
- 21.7.3 The results of these tests together with a report on the trainees' general attitude, ability, technical knowledge, aptitude, and attendance record shall be forwarded at regular intervals to the Employer, who may also require the submission of additional reports in special cases.
- 21.7.4 Methods for monitoring progress shall include; but will not necessarily be limited to:
 - a) Theoretical tests and systems of assessment;
 - b) Practical test pieces and objective systems of assessment;
 - c) Progress reports.
- 21.7.5 Records of the progress of trainees shall be kept up-to-date and shall be made available to the Employer for examination when required.
- 21.7.6 Copies of the records of individual trainees, showing all test results and reports of progress, shall be sent to the Engineer on completion of each training course.

21.8 TRAINING LOCATION AND FACILITIES

- 21.8.1 The training shall be carried out at such locations where the greatest benefit for trainees may be gained.
- 21.8.2 This may be in Azerbaijan, abroad, at places of manufacture, assembly or testing, or at such other locations as may be necessary.
- 21.8.3 All places of training shall subject to the Engineer's consent.
- 21.8.4 Details of the facilities to be provided shall be included with the detailed training programmes submitted by the Contractor.
- 21.8.5 The cost of providing trainers, training equipment, training displays etc., and the cost of providing the facilities shall be to the Contractor's account.

21.9 ADMINISTRATION

- 21.9.1 The Contractor shall be responsible for:
 - a) The reception of, and hotel and travel arrangements for the Employer's and Engineer's monitoring staff and each trainee in countries other than Azerbaijan;
 - b) The general welfare of trainees under its control.

22 KEYS AND LOCKS

- 22.1 The Contractor shall provide, for all cubicles, cabinets, panels, and gates, a means of secure locking appropriate to the location.
- 22.2 All locks shall conform to a system suited to meet the requirements of the Engineer/Employer.

APPENDICES

Appendix 1

GENERAL ARRANGEMENTS & MATERIALS

1. INDICATIVE CROSS SECTION OF DOUBLE TRACK ELECTRIFIED in Straight Track (Full Ballast Profile)

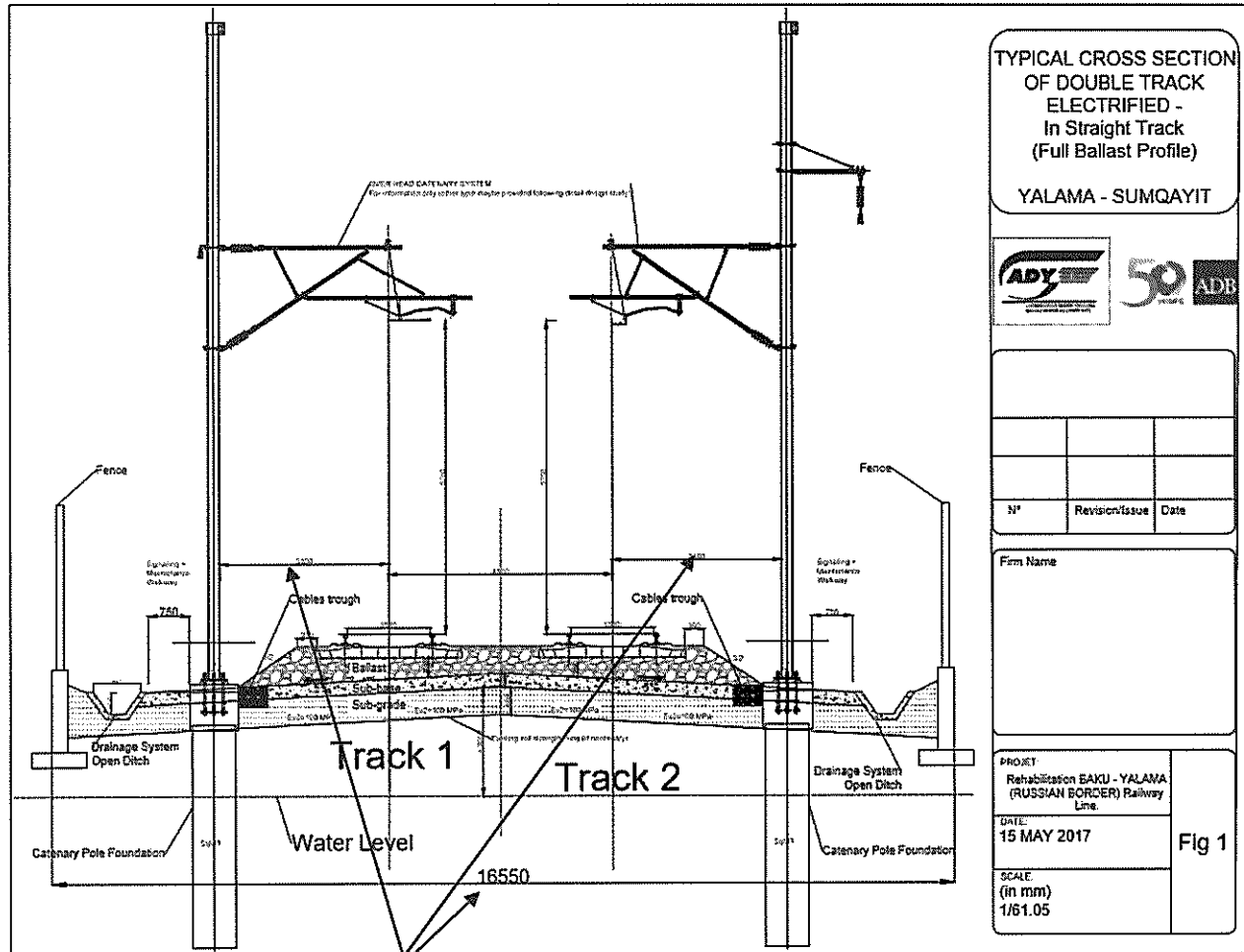

Note 1: Dimension for OCS posts and fence posts indicative only

INDICATIVE CROSS SECTION LOOKING AWAY FROM BAKU

2 INDICATIVE CROSS SECTION OF DOUBLE TRACK ELECTRIFIED
Curved Track with Cant=150mm (Reinforced Ballast Profile)

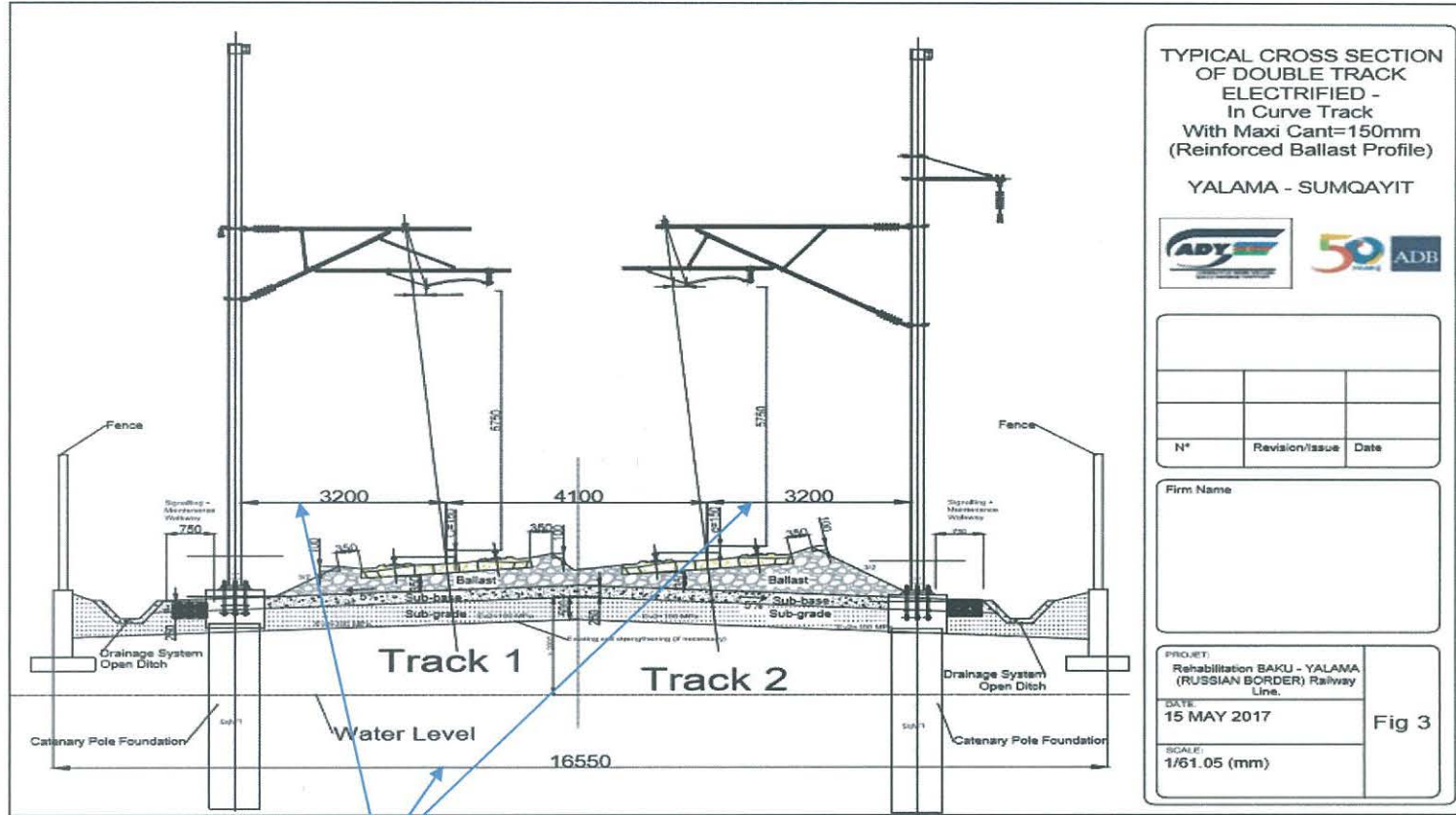

Note 1: Dimension for OCS posts and fence posts indicative only

INDICATIVE CROSS SECTION LOOKING AWAY FROM BAKU

3 INDICATIVE CROSS SECTION OF DOUBLE TRACK ELECTRIFIED in Straight Track with Outline Vehicle (Static & Dynamic)

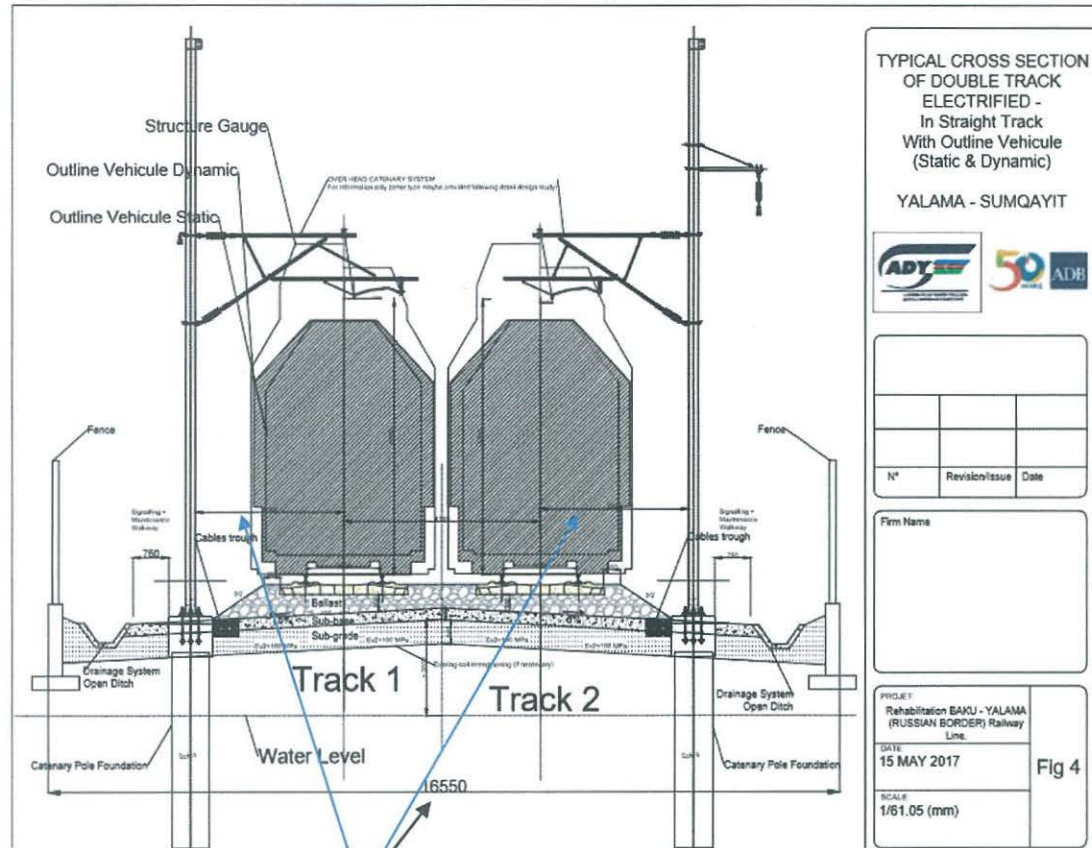

Note 1: Dimension for OCS posts and fence posts indicative only

INDICATIVE CROSS SECTION LOOKING AWAY FROM BAKU

4 INDICATIVE CROSS SECTION OF DOUBLE TRACK ELECTRIFIED

Curve with Track with Maxi Cant = 150mm and Outline Vehicle (Static & Dynamic)

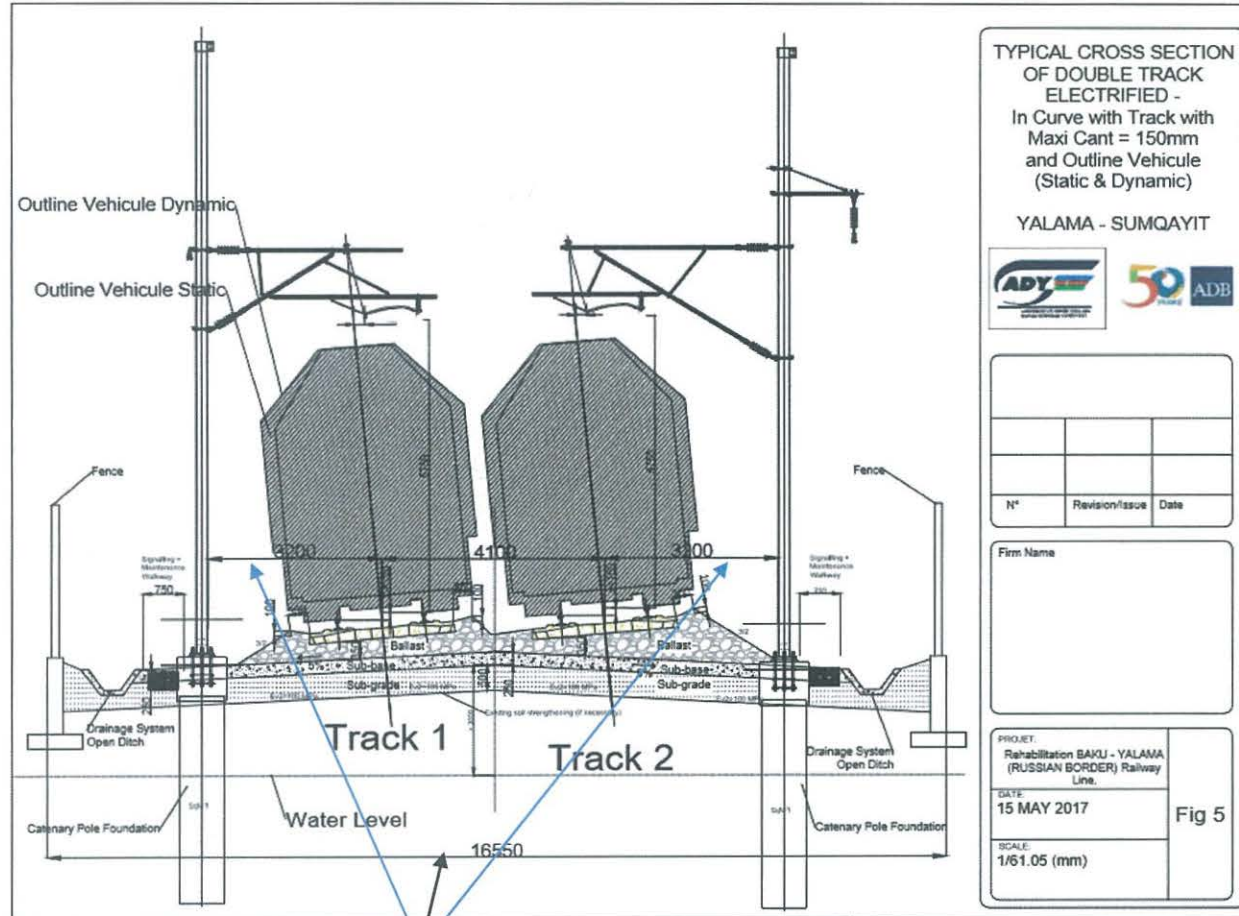

TYPICAL CROSS SECTION OF DOUBLE TRACK ELECTRIFIED - In Curve with Track with Maxi Cant = 150mm and Outline Vehicle (Static & Dynamic)

YALAMA - SUMQAYIT



N°	Revision/Issue	Date

Firm Name

PROJECT:
Rehabilitation BAKU - YALAMA (RUSSIAN BORDER) Railway Line.

DATE:
15 MAY 2017

SCALE:
1/61.05 (mm)

Fig 5

Note 1: Dimension between fence posts indicative only

INDICATIVE CROSS SECTION LOOKING AWAY FROM BAKU

5 INDICATIVE CROSS SECTION OF THREE (3) TRACKS ELECTRIFIED STATION AREA with Drainage System

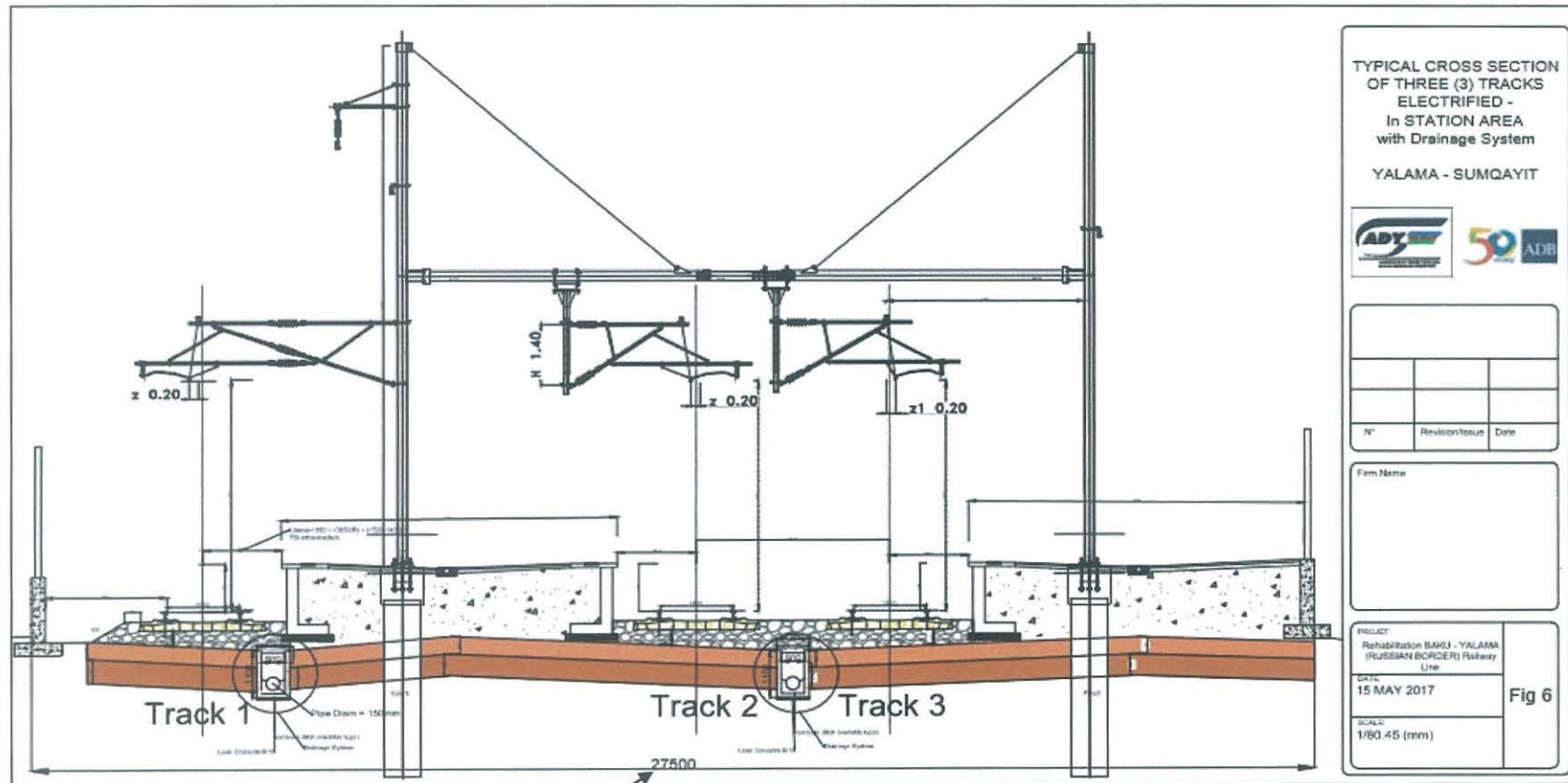

TYPICAL CROSS SECTION
OF THREE (3) TRACKS
ELECTRIFIED -
In STATION AREA
with Drainage System
YALAMA - SUMQAYIT

N°	Revision/Issue	Date
Firm Name		

PROJECT: Rehabilitation BAMU - YALAMA (RUSSIAN BORDER) Railway Line

DATE: 15 MAY 2017

SCALE: 1/80 45 (mm)

Fig 6

Note 1: Dimension between fence posts indicative only

6 RAILWAY TRACK MATERIAL

a) NEW RAILS

- Type R-65 (see Part 3)

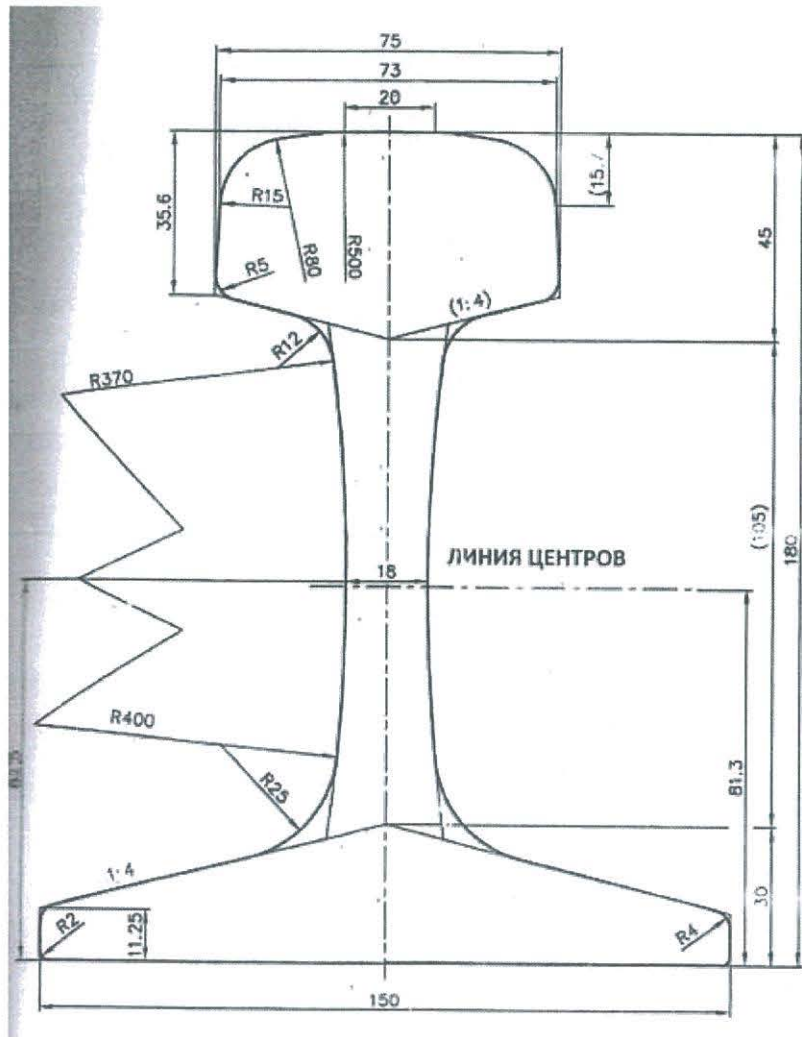

Rail Foot width (in mm)	Rail Height (in mm)	Rail Head width (in mm)	Rail Head height (in mm)	Rail Web thickness (in mm)
150	180	75	35,6	18
Section Surface (mm ²)	Weight (kg per meter)	Moment of Inertia (cm ⁴)	Section Modulus (cm ³)	
8 265	64,88	3 540	358	

b) MIXED RAILS

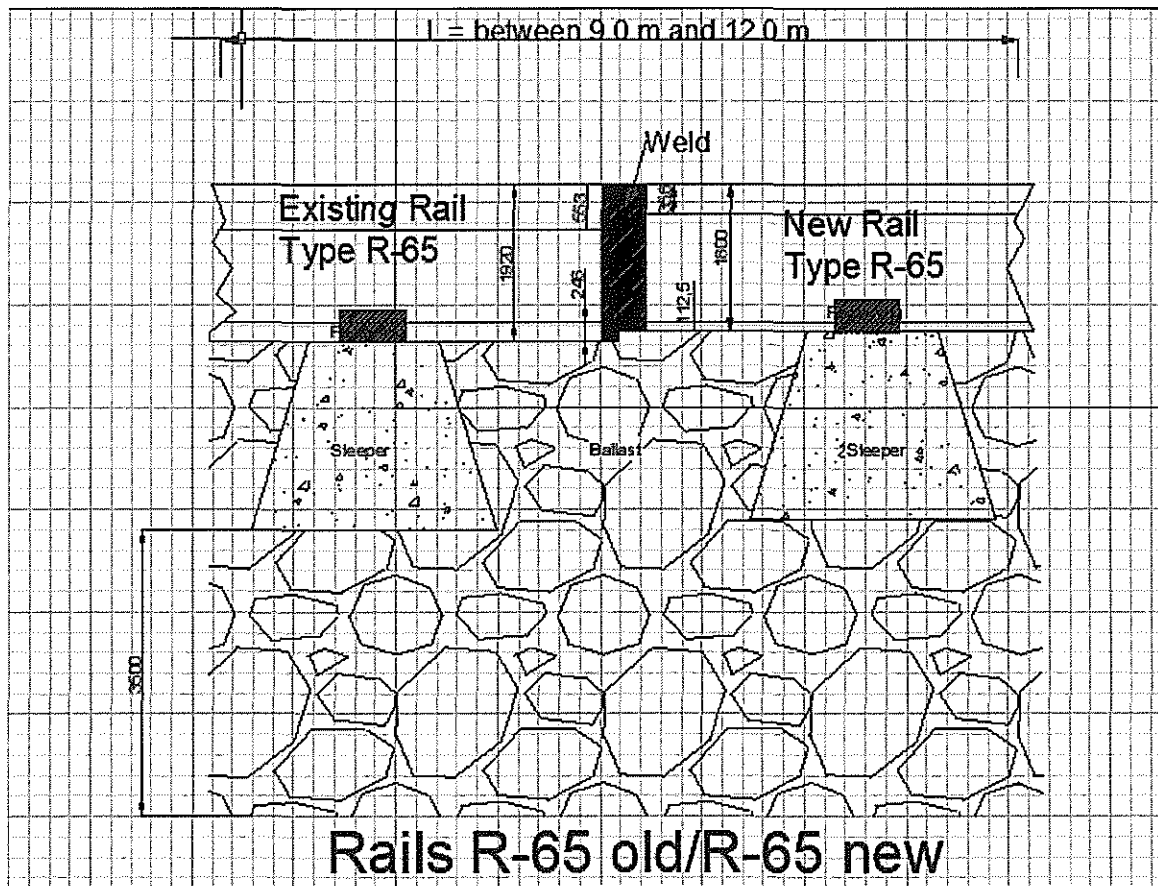

c) SECOND-HAND MATERIAL

The track sidings (Track N°3 and 4) should be renovated with second-hand rail material tested using ultrasonic testing equipment to assess rail integrity, in accordance with the following proposal:

Second hand rail shall have no more than 5% head wear

Concrete Sleepers with Elastic Fastening system = 1840 sleepers per km - 30% to be replaced with new material. The ballast and sub-ballast should be replaced with complete new or recycled material.

The welding of re-used rails in a plant with a stationary or mobile flash-butt welding machine, which shall be used for a joint less track siding, requires the following conditions to be met:

- to be checked with ultra-sound defectoscope (or similar), which shall be certified by the protocols attached to the rail package;
- to be with equal vertical and horizontal wear-out;
- to be with minimum thickness of the web along the whole length of the rail 14mm for rails R-65;
- not to have two-sides of the rail worn;

- for rails with openings, tempered ends and existing welding, these shall be preliminary cut;
- not to have permanent deformations along the rolling surface, as well as spalling, breakouts, protrusions, wheel burn marks etc.;
- used rail can have local curves in the area of the welding, in the vertical direction – maximum 0,3mm, and local curves in the area of the welding, in the horizontal direction – maximum 0,3mm. Deviations shall be measured by instrument approved by ADY's department.
- rail not to have wave-shaped wear-out;
- the length of the used rails, used for the installation of LWR, shall be not less than 20m; In long 125 m rails for LWR, it is allowed to weld one rail with length from 12 to 20m, and not more than two rails with the same length for long 300 metre long LWR. Short length rails should not be neighbouring.
- not to have eccentricity in the cross section;
- not to have visible areas with plastic deformations;
- rails shall be with steel quality grade R260;
- For bridges, it is not allowed to use re-used rails.

d) **PRE-STRESSED MONOBLOC CONCRETE SLEEPERS**

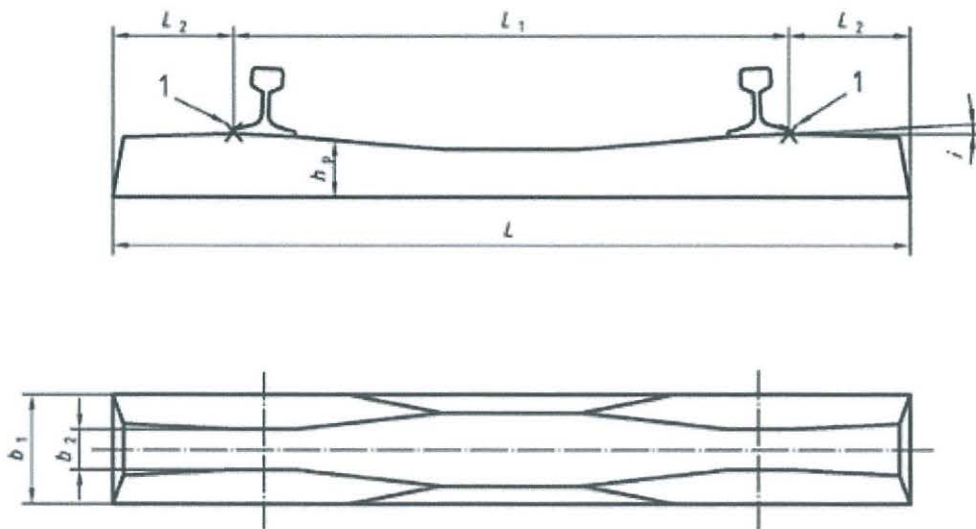
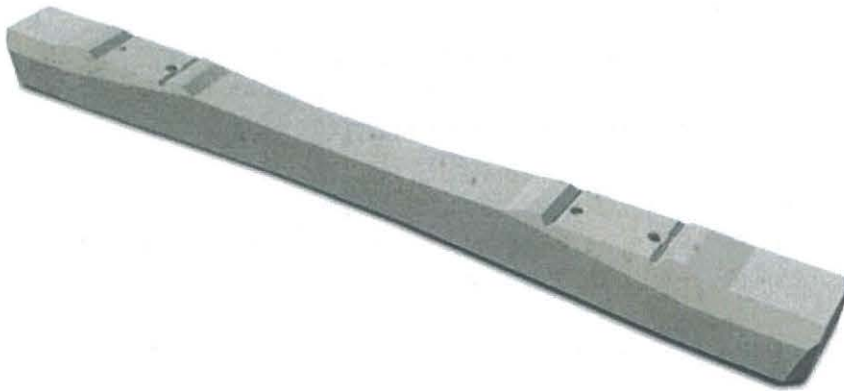

A 'standard' sleeper may be considered as satisfying the load/speed cases shown below:

Axel load / Speed	180 kN	225 kN	250 kN
120 km/hr	✓	✓	✓
200 km/hr	✓	✓	X

Non-standard sleepers shall be designed for the appropriate speed and axle load.

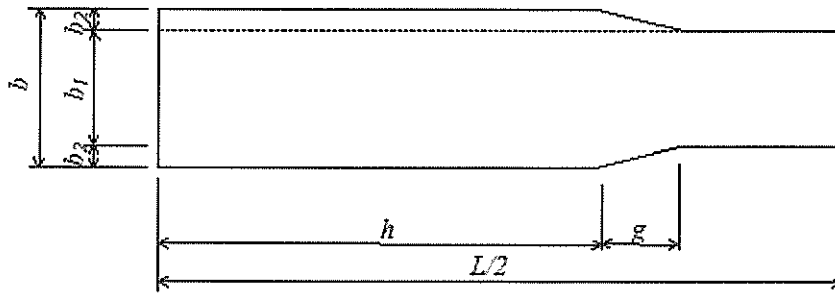

where:

- | | | |
|----------------|---|---|
| L | = | sleeper length (max 2700 mm) |
| b ₁ | = | Width of waisted section of sleeper |
| b ₂ | = | Additional width at each side of rail seat section of sleeper |
| h | = | Length of the wide section at the sleeper end |
| g | = | Length of the tapering section. |

The sleeper has a trapezoidal cross section having a width of (154/160 mm) at the top and (250/300 mm) at the bottom and a height of (210/230 mm) at rail seat.

The main requirement of concrete sleepers and bearers is the transmission of vertical, lateral and longitudinal from the rails to the ballast or other support. In use, they are also exposed to moisture which can result in detrimental chemical reactions within the sleepers and to frost damage.

6.d.1 Common Characteristics

The track is an assembly of transverse concrete sleepers or bearers secured to the rail by fastening system and supported by ballast or other support. It is characterized by the gauge of the track, the rail profile, the inclination of the rails and the spacing of the concrete sleepers and bearers. Refer to EN 13230 for compliance details.

- *Loading:*

The Track is subjected to repeated loads in three (3) different directions, generally applied simultaneously:

- Vertical load depending on support condition,
- Transverse load from guiding forces, transverse resistance, etc.
- Longitudinal loads from acceleration and braking, thermal stresses in continuous welded rails, etc.

Under all loading conditions, the track shall to retain its geometry including gauge, top level and alignment.

- *Load distribution:*

The assembled rail, fastening system, concrete sleepers or bearers on ballast or other support shall be considered as a beam on a continuous resilient support.

The moments of inertia of the rail profile, the spacing of the concrete sleepers and the elasticity of the whole assembly on its support have an influence on the vertical distribution of the vertical loads applied on the rails. The coefficient for longitudinal distribution of the design load is evaluated for each case according to Zimmerman or other appropriate formula. There should be no longitudinal distribution of impact load with a frequency higher than the natural frequency of the track.

- *Design bending Moment:*
 - *Bending moment at rail seat:*
 - Wheel loads generate positive bending moments (*Mdr*) under the rail seat.
 - Negative bending moment (*Mdr_n*) under the rail seat can arise from the vertical movement of the track, harmonic motion from rail corrugation and curving forces of the sleepers under dynamic loading and handling during track works.
 - *Bending Moment at the Centre part:*
 - Positive bending moment at the centre part (*Mdc*)
 - Negative bending moment at the centre part (*Mdc_n*).

6.d.2 Data to be supplied by the Contractor:

The Contractor, as part of the definitive design, shall specify the followings data:

- All design bending moment (*Mdr*, *Mdc_n*),
- Impact coefficients,
- Required test and choice of options,
- Drawings and specification necessary to define:
 - Critical dimensions (length, width, depth at rail seat, etc.)
 - Fastening system interface and geometry layout
 - Particular tolerance
 - Conductor rail insulator support
 - Scope of the test arrangements and procedures indicating whether the options are used,
- Absolute maximum and minimum weight of the concrete sleepers or bearers (kg/sleeper or kg/m)
- Any additional technical specification,
- Rail profile definition,
- Minimum strength class of concrete (optional)

6.d.3 Material:

- *General Requirement:*

All material shall comply with European Standards. Great attention shall be exercised in the selection of material in order to ensure the long-term durability of the concrete. Consideration shall be given for:

- Freeze-thaw resistance,
- Porosity
- Abrasion resistance or attrition.

- *Cement*

Typical precautions:

- Use of low alkali cement with total alkali content less than 0.60%
- Use pozzolanic materials as partial cement replacement (if possible)
- Use of Non-reactive aggregate,
- The total mass of reactive alkali in the concrete not exceeding 3.5 kg/m³
- For the cement shall be Portland class I with minimum strength grade class 42.5, complying with EN 197-1 is recommended

- *Aggregates*

The manufacturer shall supply following information to the purchaser concerning aggregates to be used:

- Grading curve,
- Petro graphic analysis (susceptibility to alkali-silica and alkali-carbonate reactions, presence of particles leading to poor abrasion resistance, presence of absorbent particles leading to frost damage)

- Chemical analysis (maximum chloride, sulphate and organic material contents)
- *Mixing water (potable water)*
- *Admixtures (in accordance with European Standards)*
- *Concrete*

The concrete shall generally comply with EN 206-1:

- The minimum compressive strength shall be class C50/60 MPa unless otherwise required by the purchaser,
- The water/cement ration shall be less than 0.45
- The minimum cement content shall be 300kg/m³
- Compaction of the concrete shall be sufficient to minimize water penetration
- Heat treatment can be used
- *Steel*
 - Pre-stressing tendons according EN 10138
 - Reinforcing steel shall comply with ENV 10080
 - Steel connecting bars (See EN 13230-3)

The basic values of the different dimensions and the time period during which they shall be measured shall be determined by the purchaser

6.d.4 Test on Sleeper:

The tests carried out are:

- Static bending test: a static load condition to confirm the behaviour of the concrete sleeper or bearer. Required for design and routine test.
- Dynamic bending test: a dynamic load condition which applies a pulsating and increasing load to the concrete sleepers or bearers to simulate the situation in the track of impact load. Only required for design approved tests
- Fatigue bending test: a dynamic condition to simulate the load applied to the concrete sleeper by traffic

6.d.5 Test on concrete:

The tests carried out are:

- Design approval test on the concrete mix and routine tests on the concrete used,
- Tests on the properties of concrete carried out in accordance with EN 206-1.

6.d.6 Test in combination with the Fastening system:

The tests carried out are:

- Design approval test, if required, which shall be defined by the purchaser according to EN 13481-2,
- Electrical insulation design approved test, if required, shall be carried out
- Routine tests, if required shall be defined by the purchaser.

6.d.7 Additional Tests:

- Abrasion resistance on fine aggregate,
- Freeze-thaw resistance
- Water absorption of concrete on atmospheric pressure.

6.d.8 Bending Moment calculation:

- Design shall comply with EN 13230 or UIC 713 - 2004
- Design Bending Moment:

As Example: The calculation of the design load considers the following criteria:

- Q – Nominal wheel load in kN
- Dynamic factor of wheel due to defect in the vertical profile of the track at:
 - $V \geq 200 \text{ km/hr} = 1.75$
 - $V < 200 \text{ km/hr} = 1.50$

- A – 0.5 load distribution coefficient
- 1.35 factor of the sleeper reaction due to support faults
- 1.60 factor bending moment in the rail seat due to irregularities in the longitudinal support of the sleeper

Design Bending Moment: The level arm to be considered for the calculation of the design related to the projection of the sleeper beyond the rail.

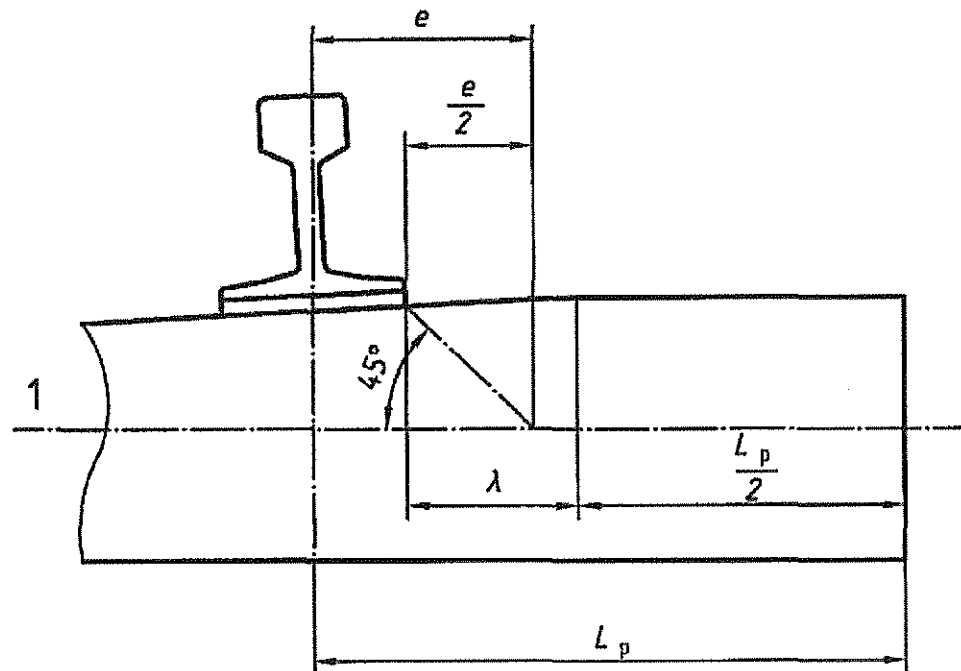

Key

1 Neutral axis

$$\lambda = \frac{L_p - e}{2}$$

where :

λ is the lever arm

L_p is the distance between the rail seat axis and the end of the sleeper at the bottom.

e is half the length of the load distribution at the neutral axis of the sleeper, in the rail seat section.

Figure E.1 – Design bending moment calculation

● **Impact Coefficients:**

The impact coefficient for Monoblock or twin block sleepers is:

- For the static test on the rail seat section:
 - $K_{1s} = 1.8$
 - $K_{2s} = 2.5$
- For the dynamic test in the rail seat section:
 - $K_{1d} = 1.5$
 - $K_{2d} = 2.2$

The EN 13230-2 – Pre-stressed Monoblock Sleepers, defines additional technical criteria relating to pre-stressed Monoblock sleepers, in particular regarding the tests.

The EN 13230-4 – Concrete bearers for Turnouts, defines additional technical criteria and control procedure as well as specific tolerance limits to the design and manufacture of pre-stressed bearers for switches and crossings with maximum length of 5.5 m. For bearers, longer than 5.5 m are considered as special element and it is essential that they comply with EN 13230-5.

6.d.9 Concrete bearers for turnouts – Special requirement:

- Design bending shall be with positive and negative design bending moment capacities with the objective to keep them straight.
- Positioning of the fastening components:

An area of the concrete section shall be free from pre-tensioning tendons for the location of fastening components

- Tolerances:

The maximum tolerances are specified on EN 13230-1.

- Flatness = 1mm
- Gradient = 0.5 per 150mm
- Vertical deviation = 2mm on both direction

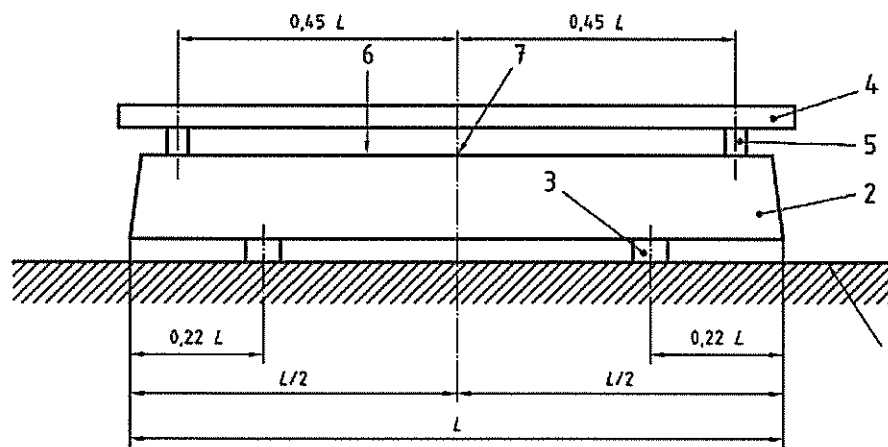

Key

- 1 Rigid support
- 2 Bearer
- 3 Support (50 x 50 mm section) across width of bearer
- 4 Straight datum (laser, wire, etc)
- 5 Support across width of bearer
- 6 Top surface of bearer
- 7 Measurement point

Figure 2 — Vertical deviation measurement

- Product Testing, according to the following symbols:

The following symbols are used:

M	positive design bending moment, in kN.m;
Mn	negative design bending moment, in kN.m;
Fb_0	positive initial reference test load, in kN;
Fb_{0n}	negative initial reference test load, in kN;
Fb_r	test load which produces first crack at the bottom of the bearer, in kN;
Fb_m	test load which produces first crack at the top of the bearer, in kN;
$Fb_{0,05}$	test load for which a crack width of 0,05 mm persists at the bottom of the bearer after removal of the load, in kN;
$Fb_{0,05n}$	test load for which a crack width of 0,05 mm persists at the top of the bearer after removal of the load, in kN;
Fb_B	test load which cannot be increased when the bottom of the bearer is cracked, in kN;
Fb_{Bn}	test load which cannot be increased when the top of the bearer is cracked, in kN;
Fb_u	lower test load for the fatigue test: $Fb_u = 0,25 \times Fb_0$, in kN;
k_b	impact coefficient for positive static test;
k_{bn}	impact coefficient for negative static test;
k_{bB}	impact coefficient for fatigue test.

- The Tests arrangements are defined:

For the static and fatigue tests is according the figure 3

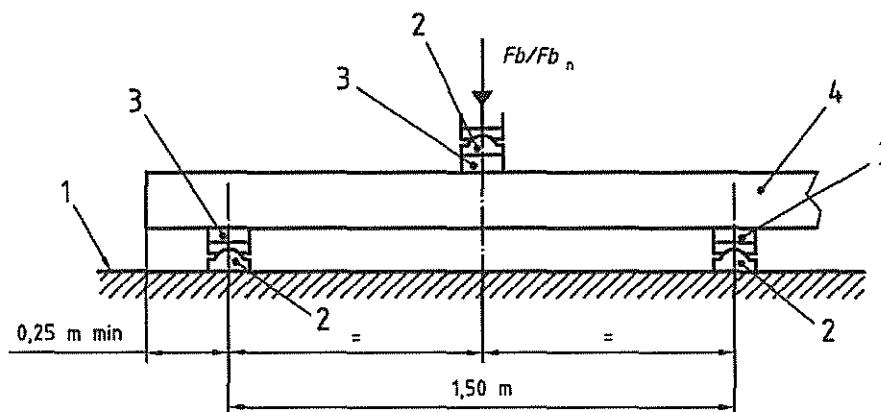

Key

- 1 Rigid support
- 2 Articulated support (see annex A for details)
- 3 Resilient pad (see annex A for details)
- 4 Bearer

Figure 3 — Test arrangement

For the static test, the bearer shall have arranged as the Figure 3 above

For the fatigue test, the load F_b shall be applied at the centre section of the bearer

- Test Procedures

- Test loads

F_{b0} is calculated according the following formula

$$F_{b0} = \frac{M}{0,35} \text{ in kN}; \quad F_{b0n} = \frac{Mn}{0,35} \text{ in kN.}$$

The static test procedure is show on the following figures

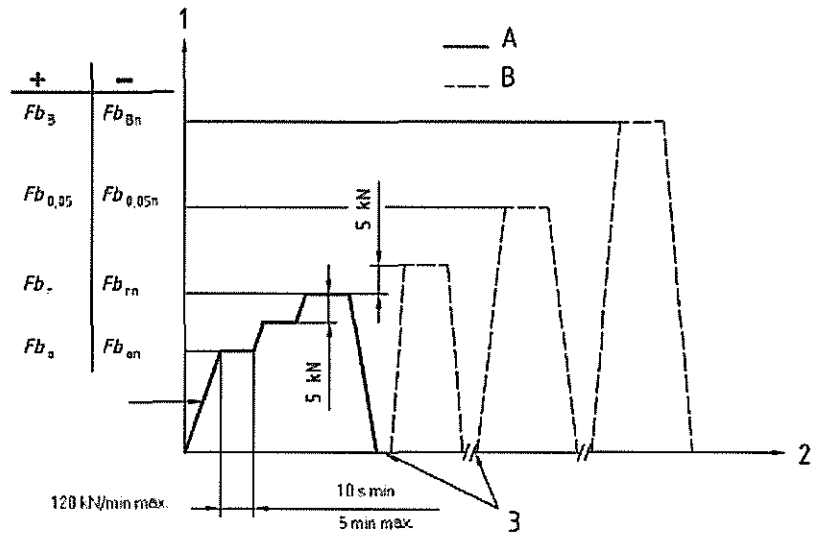

- Key
- 1 Load
 - 2 Time
 - 3 Crack checking
 - A Required part of test
 - B Optional part of test

Figure 4.1 — Static test procedure for design approval test

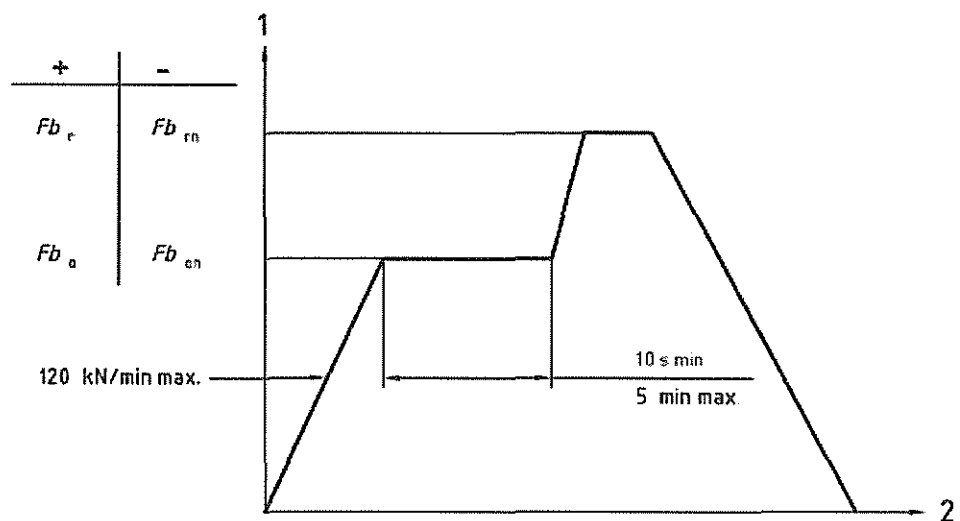

Figure 4.2 — Static test procedure for the routine test

- Acceptance criteria:
 - The test is to be conducted according to the requirements of the EN 13230-1
 - Static Tests:

The acceptance criteria for the design and routine static tests are as follows:

- $F_{bT} > F_{b0}$;
- $F_{bTm} > F_{b0n}$;
- $(F_{bB} \text{ or } F_{b0,05}) > k_b \times F_{b0}$;
- $(F_{bBn} \text{ or } F_{b0,05n}) > k_{bn} \times F_{b0n}$.

The coefficients k_b and k_{bn} shall be provided by the purchaser.

- Fatigue Tests:

In

CO

The acceptance criteria for the fatigue test after $2 \cdot 10^6$ cycles are as follows:

- crack width is $\leq 0,1$ mm when loaded at F_{b0} ;
- crack width is $\leq 0,05$ mm when unloaded;
- $F_{bB} > k_{bB} \times F_{b0}$ when the load is load continuously increased at a rate of 120 kN/min from the unloaded condition until failure F_{bB} . The coefficient k_{bB} shall be provided by the purchaser.

e) Elastic Fastenings

Typical Examples

These are only examples of typical rail fastenings and is not intended to represent all types of rail fastenings that are available.



Illustration 1. Pandrol e-clip



Illustration 2. Pandrol "fast clip"



Illustration 3. Vossloh Tension clamp



Illustration 4. Vossloh W14

f) Glued Insulated Rail Joints

- 6.f.1** Glued Insulated Rail Joints (GIRJ) shall be of a proven proprietary six (6) hole type suitable for use with rail section type R-65.
- 6.f.2** The GIRJ shall be formed by a single cut in the centre of a minimum 12.5m length of rail of grade R350HT.
- 6.f.3** GIRJ fishplates shall be manufactured in accordance with UIC 864-4 with minimum tensile strength of 550MPa and to the profile required for R-65 rail.
- 6.f.4** The fishplates shall be connected to the rail to make the joint using compression studs (Huck Bolts or similar) and shall be minimum grade 10.9 in accordance with UIC 864-2 and shall be corrosion protected by sherardized coating or by galvanising.
- 6.f.5** All holes made in the rail for the compression studs shall be cold expanded using cold expansion equipment to make a zone of residual compressive stress around the hole to increase fatigue life.
- 6.f.6** The insulated post shall be designed with minimum width of 4 mm. The insulated components for the stud and fishplate insulation mechanical, electrical and thermal properties values shall be defined and noted by the manufacturer to fulfil the insulating requirements
- 6.f.7** The following information of the insulated components shall be provided by the Contractor for the Engineer's approval:
- i. Material properties
 - ii. Flexural strength,
 - iii. Tensile strength,
 - iv. Compression strength,
 - v. Impact strength,
 - vi. Surface electrical resistance,
 - vii. Disruptive voltage,
 - viii. Heat stability.
- 6.f.8** The type and portion of adhesive used to glue the assembled Steel Fishplates, Steel Bolts and Nuts and the Insulating Component to the Rails, including its technical specification and properties shall be provided by the Contractor for the Engineer's approval.
- 6.f.9** The assembled GIRJ shall be tested to demonstrate that it meets the insulation requirements. The Contractor shall have the GIRJ tested and witnessed by up to three personnel from the Employer and Engineer, to demonstrate it meets the following requirements:
- a) Electrical resistance in dry conditions (minimum impedance with 500Vdc shall be 10 Mega ohm).
 - b) Electrical resistance of the GIRJ after immersion in potable water with 10% solution of sodium alkali, 10% solution of Sulphur acid, diesel fuel, petrol/gasoline for 24 hours and measure 30 seconds after removal, shall be a minimum of 10 kilo-ohm when measured using 500 Vdc.

- c) Stroke rolling test and slow bend test shall be carried out in accordance with AREMA Manual for Railway Engineering – Section 2.12 for non-bonded encapsulated insulated rail joints, or similar approved code.
- d) The stroke rolling test shall be undertaken with a wheel load of 300kN and shall show no failure or permanent bending exceeding 2mm after 2 million loading cycles.

6.f.10 The Contractor shall ensure the GIRJ's be installed as follows:

- a) Located midway between fasteners and shall not be staggered across the gauge by more than 10mm;
- b) With standard rail fastenings either side;
- c) Have the nut end of the stud installed on the gauge side of the track (i.e. between the rails).

6.f.11 The Contractor can propose the option to use Glued Insulated Rail Joint (GOST 32695-2014, GOST 33185 — 2014) provided it meets or exceeds the requirements set out above

g) Mechanical Insulated Rail Joints (Block Joints)

- 6.g.1 Mechanical insulated rail joints (MIRJ) or sometimes named "Dry Block Joints" i.e. no adhesive, shall be placed in the track at locations identified by the interfacing Signalling Contractor (or if the Signalling Contract is not yet awarded, the locations will be identified by ADY signalling personnel through the Engineer).
- 6.g.2 MIRJ shall follow the recommendations set out in UIC Technical Document A5/RF0 "*Functional analysis and construction principles of insulated joints.*"
- 6.g.3 MIRJ's shall be assembled and installed in the track at the advised locations on a temporary basis until the new signalling system is installed.
- 6.g.4 Rail can be welded into CWR using these temporary MIRJs. When the joint is no longer required the ends of the rail can be prepared (straightened and trimmed) and then welded using a mobile flash-butt welder.
- 6.g.5 After the new signalling system has been installed the MIRJ shall be removed and the rail re-welded into CWR. To facilitate the welding and maintain the integrity of the running rail, six (6) hole fish plates shall be used but only the back two (2) on each rail shall be bolted, thus the rail shall have only two (2) holes drilled to accept the MIRJ.
- 6.g.6 The diagram below shows a cross-section of the MIRJ. Note that the fish plates have three (3) holes but only the back two will be used.

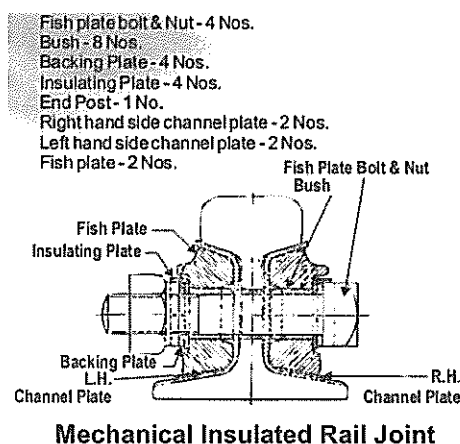

h) Ballast

- Profile of Ballast: Full Ballast Profile

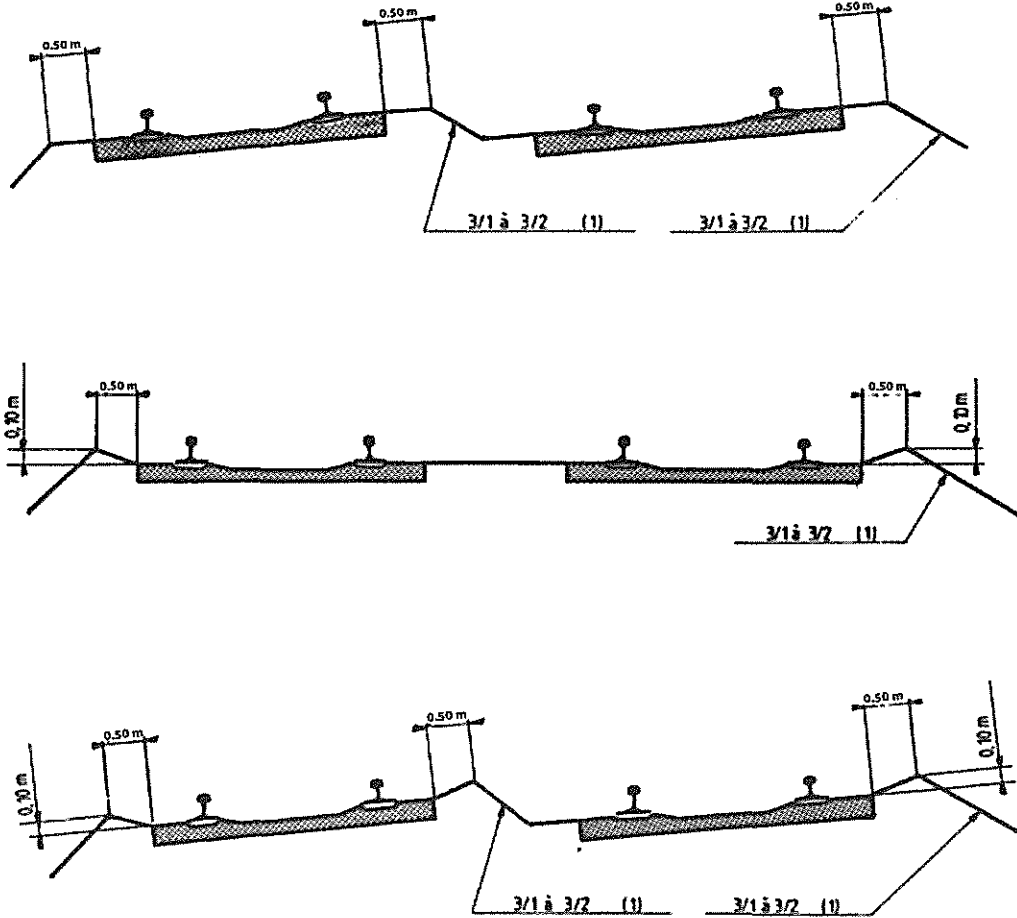

- Profile of Ballast: Reinforced Ballast Profile
- Recommended ballast size specification:
 - Ballast for track between 22.4 mm to 63 mm

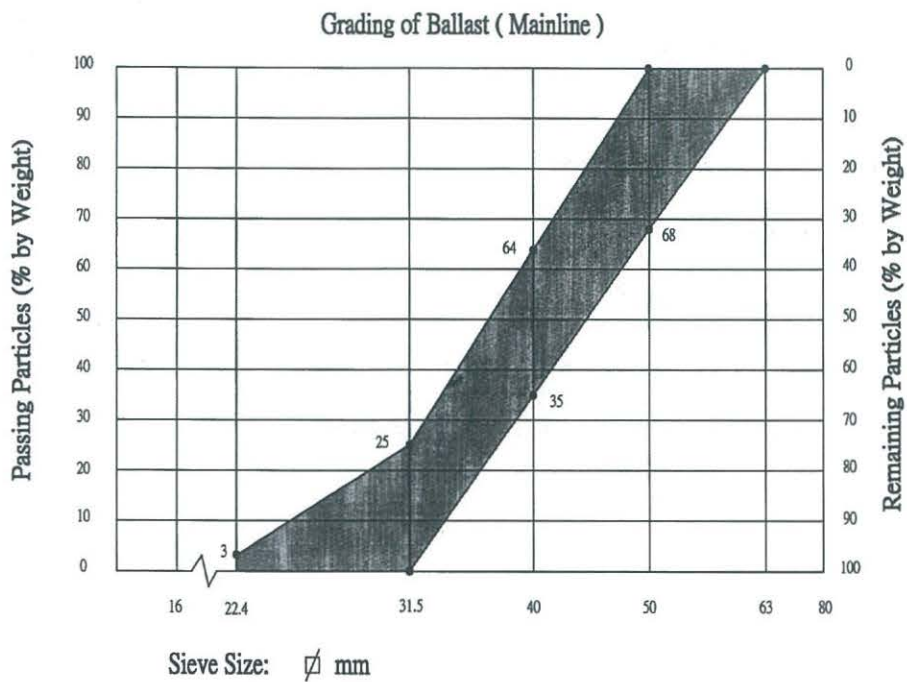

Concerning the Ballast profile, the recommendation is to follow the European requirement EN 13450 and to install the ballast in accordance with the following Table:

Density of Sleepers per km	Minimum Radius of Curve (in m)	
	Full Ballast Profile	Reinforced Ballast Profile
1840	✓	
2000	✓	200

- Ballast thickness:

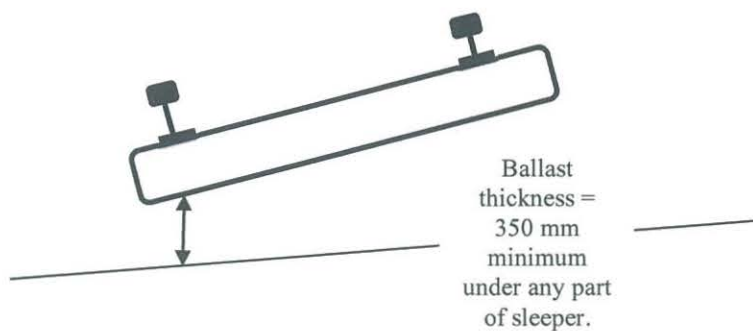

- Ballast Installation:

The ballast is installed with thickness of 350 mm minimum below any part of the sleepers and, in accordance with the full ballast profile and/or reinforced ballast profile on curve, with radius < 200 m. Sand layer should be introduced to protect the geotextile (if installed) and if necessary.

i) Excavated Material & Sub-Ballast

- 6.i.1** To maintain the same Top of Rail (ToR), the track excavation under sleepers shall be carried out to a depth of at least 1050 mm (with tolerance -12mm +50mm) under the designed ToR and for a width of at least 3100 mm from the centreline of track to the field side(s) of the track, and for the whole area between the outermost tracks of multiple tracks where multiple tracks are two or more tracks. This will remove any existing ballast and sub-ballast below all sleepers. The excavated material can be re-blended to suit the grading requirements of the sub-ballast, or shall be disposed of in locations off-site or on-site as agreed with the Engineer.
- 6.i.2** If the excavated material is contaminated with any material above the limits imposed by MENR, the excavated material shall not be re-blended, recycled nor re-used, and shall be disposed of at locations approved by MENR.
- 6.i.3** If the excavated material is suitable to be recycled by re-blending to suit the required sub-ballast grading or alternatively used as clean fill, it can be used to fill up lineside non-waterway ditches that are located along the railway. Some ditches were initially borrow pits used to win material for the railway embankment at the time of construction. If the excavated material is to be placed in these ditches, pre-approval from the Engineer is required, and approval will not be unreasonably withheld provided the excavated material contamination limit is below that defined by MENR. Refer to UIC 719 for backfill requirements.

E = 1050

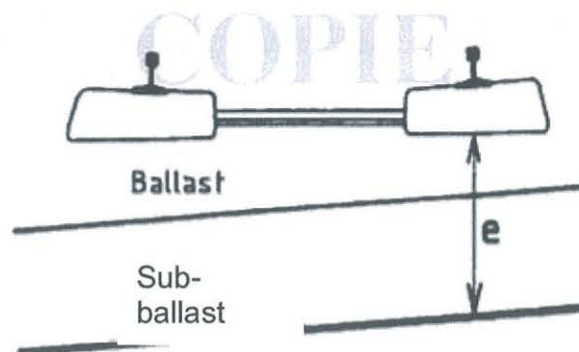

- 6.i.4** The sub-ballast layer needs to be removed to 1050mm (-12mm +50mm) below the designed top of rail, re-laid to a minimum thickness of 300mm and compacted before ballasting.
- 6.i.5** The sub-ballast to be installed must prevent the intermixing of ballast and sub-grade, and also prevent the upward migration of sub-grade particles into the ballast.
- 6.i.6** Prevention of intermixing and migration is achieved by using proper sub-ballast gradation as shown in the Table – Gradation of Sub-Ballast below.

j) **Sub-Ballast Requirement:****GRADATION OF SUB-BALLAST**

Size (mm)	Percentage (%) Passing
45.0	100
31.5	85 – 99
16.0	73 – 92
8.0	62 – 82
4.0	50 – 71
2.0	40 – 60
1.0	32 – 53
0.50	23 – 43
0.25	14 – 32
0.125	7 – 17
0.063	0 – 7
0.02	0 – 3

- 6.j.1 The Sub-Ballast shall be water impermeable and in accordance with UIC 719, designed, shaped and constructed so as to drain the water into the longitudinal trenches, French drains and drainage beside the track as designed.
- 6.j.2 The sub-ballast shall be compacted to at least a deformation modulus of 50 MPa for mainlines and 40 MPa for Tracks 3 & 4 before ballast is placed on the sub-ballast.
- 6.j.3 The sub-ballast layer gives a solid support for the top ballast and reduces the seepage of water from the underlying ground.
- 6.j.4 Where required by the Definitive Design, geotextile and/or geo-grid (see illustration below), shall be laid between the sub-grade and the sub-ballast.
- 6.j.5 Sub-ballast thickness shall not be less than 300mm in-depth at any point.
- 6.j.6 The sub-ballast shall have no organic material.

k) **Geotextile Material Specification**

- 6.k.1 About the manufacturing the geotextiles have distinctive characteristics. Their requirements are defined by their function in the ground platform (GP). The main characteristics are defined in a laboratory. Refer to EN 13250
- 6.k.2 The values of the main characteristics of the woven textiles produced in Azerbaijan are shown in Table 1.

Table 1 Laboratory data of woven textiles tests:

Indicators	Measure	Type	
		300	500
Mass of unit area	g/m ²	325±10	542±18
Thickness at 2 kPa tension	mm	3,04±0,1	4,3±0,13
Tension strength – longitudinal	kN/m	12,3±1,5	21,0±2,4
Tension strength – crosswise	kN/m	16,8±0,8	31,6±1,7
Relative extension during rupture – longitudinal	%	106±4	146±4
Relative extension during rupture – crosswise	%	88±4	104±4
Static drilling strength (CBR)	kN	1,869±0,096	3,183±0,067
Dynamic drilling strength (cone)	mm	5,3±1,2	2,1±1,0
Effective pore diameter (D _w)	(:m)	94	44,2
Water-permeability normal to the plane	l/s	0,348	0,209
Water-permeability in the plane	m ² /s	56,2.10 ⁻⁵	98,81.10 ⁻⁵
- longitudinal			
- crosswise			

- 6.k.3 The geotextiles with area mass of 300 g/m² shall be used where required for drainage facilities and those with mass from 500 g/m² shall be used together with the geo-grid to reinforce the sub-base.
- 6.k.4 The geotextile laid under a protective layer, separates it from the earth bed soil. If the inserted geotextile is not high-strength it does not increase the bearing capacity of the protective layer, and only has separating function and should respond to the following requirements:
- $d_t \max < d_{90}$, where $d_t \max$ is the maximal size of the geotextile pores in mm, d_{90} – diameter of the soil granules in the GP structure plane with 90% of the total mass in mm.

- 6.k.5 The separating geotextile implements also a filtrating function, because of which it is not obligatory the protective layer material to respond to the Terzaghi filtrating criteria, but it should be pervious and non-frost.
- 6.k.6 The protective layer with geotextile should be designed to drain the water into the longitudinal trench and drainage.
- 6.k.7 The width of the geotextile shall correspond to the width of the sub-base but a minimum of 3100mm. When the width of the geotextile is smaller the stripes are connected via covering one over the other at length not less than 0.50 m. The geotextile stripes could be also connected via sewing, sticking or thermal sticking at length between 0.15 and 0.20 m. The geotextile laid over sub-base should be covered as soon as practicable with protective layer.
- 6.k.8 The geotextiles should be laid in drainage when the filling inert material does not respond to the filtration criteria regarding to the environment soil. The geotextile implements the filtration function, it means that it prevents the infiltration of small soil fragments from the environment soil, and this requirement should be fulfilled:
- $d_t \max < d_{90}$ where d_t is the maximal size of the geotextile pores in mm,
 - d_{90} - diameter of the soil grain at 90% by the total mass.
- 6.k.9 If the drainage is executed with geotextile it is possible the drainage to be without pipes and the filling to be with material with different grain sizes, for example crushed stone, ballast, etc.
- 6.k.10 When the pipes are laid in the drainage they could be covered with geotextile, which will prevent the infiltration of small fragments and the possibility for blocking the pipes.
- 6.k.11 Before laying the geotextile, the drainage bottom should be shaped with the relevant inclination and all the unevenness to be removed. It is recommended to be used a geotextile stripe and its ends to be fixed for the canal borders with filling inert material. If it is necessary two geotextile stripes could be connected via over covering at minimum 0,30 m.

1) **Geo-Grid**

6.1.1 For geo-grid, only one type of geo-grid is required for the strengthening of the sub-base in particular locations. Refer to EN 13250 for compliance requirements.

6.1.2 The detail below sets out the minimum technical requirements for the Geo-grid. Geo-grid samples complying with these minimum criteria shall be presented to the Engineer for final acceptance before installation into the Works.

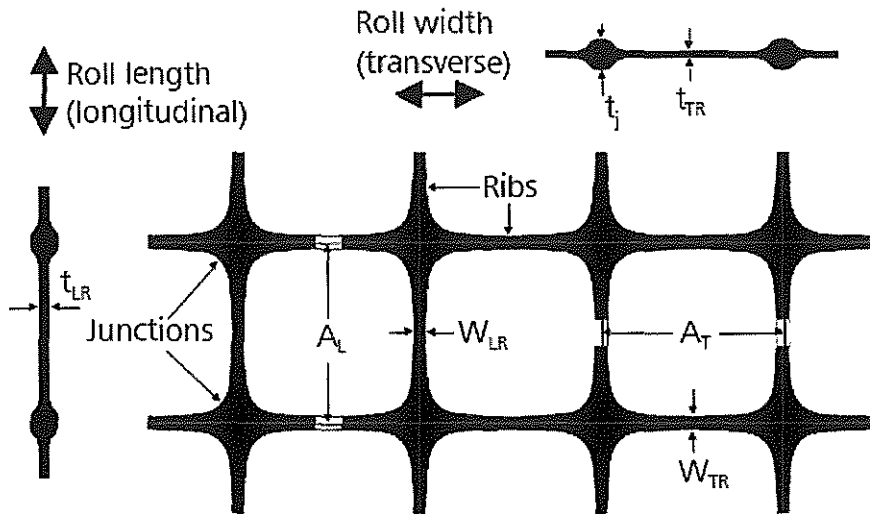
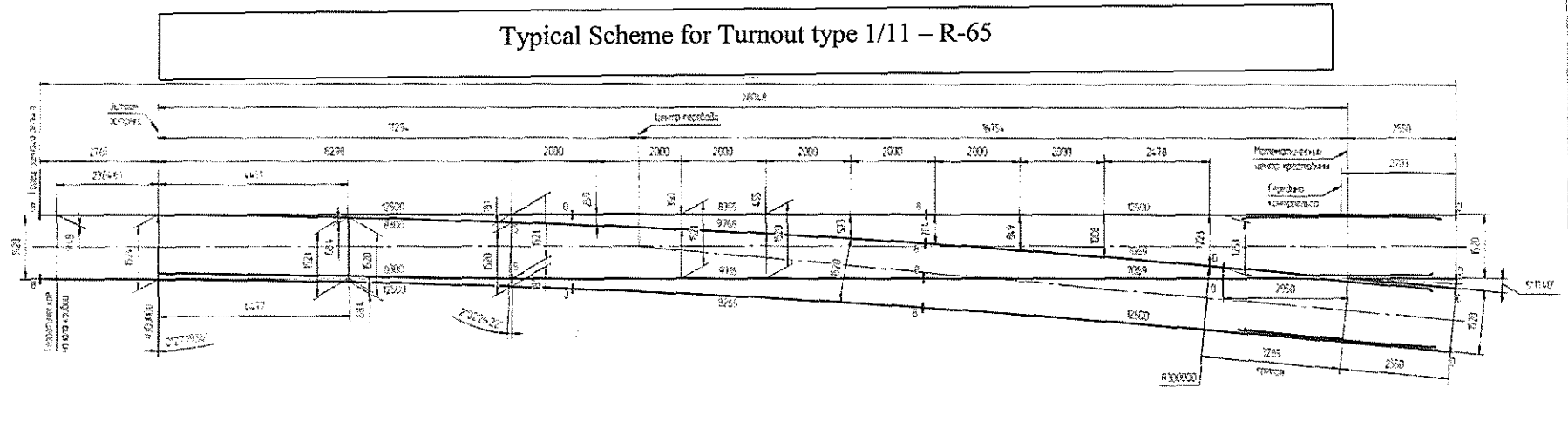

TABLE 18.10 GEO-GRID PARAMETERS

Polymer	Propylene	A_L	31 to 33mm
Carbon Black	Min 1.8% to 2%	A_T	31 to 33mm
Mass	0.53 kg/m ²	W_{LR}	2.2 to 2.3mm
T_{ult} (Longitudinal & Transverse)	Min 40 kN/m	W_{TR}	2.5 to 2.7mm
Load @ 2% strain (Longitudinal & Transverse)	Min 14 kN/m	t_j	5.8 to 6mm
Load @ 5% strain (Longitudinal & Transverse)	Min 28 kN/m	t_{LR}	2.1 to 2.3mm
Approx strain @ T_{ult} (Longitudinal & Transverse)	Max 11%	t_{TR}	1.3 to 1.5mm
Junction strength (Longitudinal & Transverse)	Min 95%		

m) Turnout type 1/11 & 1/9:



Turnout shall comply with GOST Standards/EN 13232

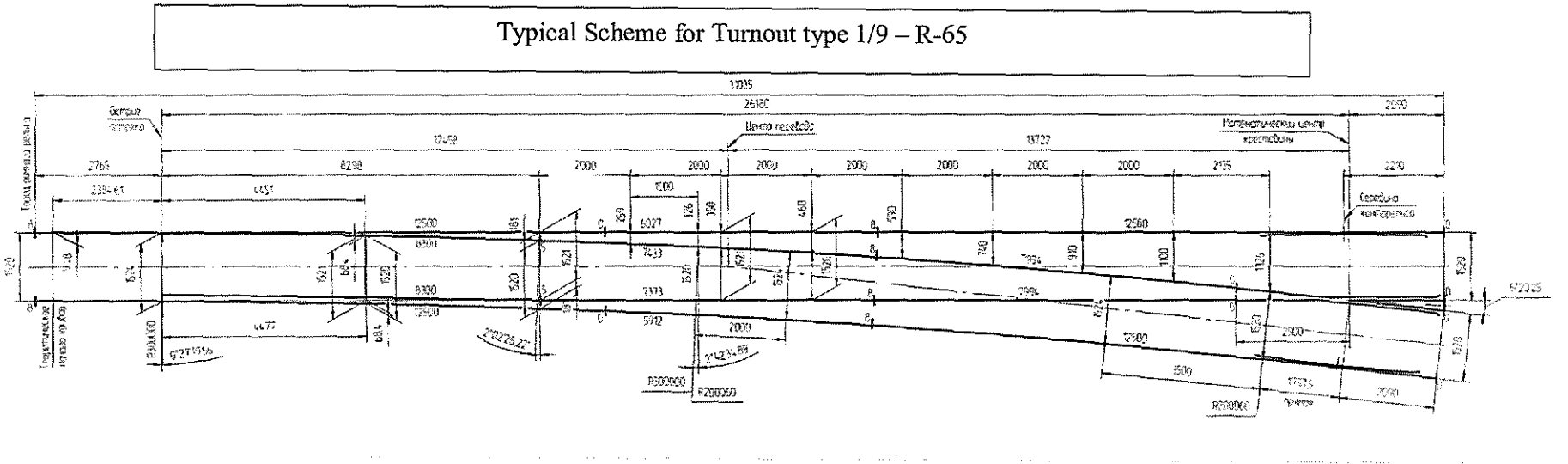

Turnout shall comply with GOST Standards/EN 13232

The places for measuring of the track spacing, the level, the width of the channels and worn-out in ordinary turnouts are shown on the scheme:

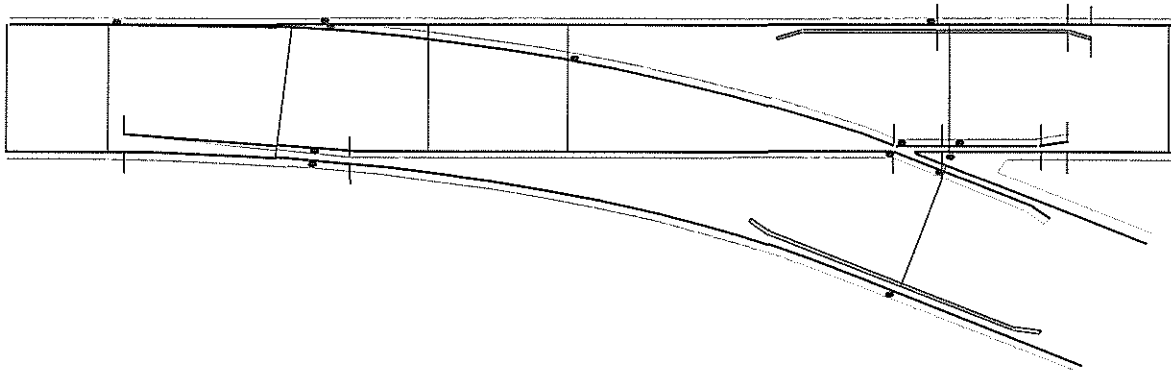

n) Refurbishment of Used Turnouts for Tracks 3 & 4

Selected and refurbished used turnouts shall be installed on Tracks 3 and 4 at stations. The Contractor shall select the least worn /damaged turnouts, refurbish these and install in the locations shown on the drawings. The refurbished turnouts will be installed using hardwood timber bearers, and refurbished fasteners with baseplates.

Where it is required to adjust siding tracks to align with the installed refurbished contracts, this shall be included within the Contractor's scope.

Existing signalling equipment shall be reinstalled and commissioned. The used point machine shall be removed and returned to the ADY store and a new point machine shall be installed and commissioned.

The new point machine shall be the same type as installed on new turnouts, and shall come fitted with an DC motor and a AC motor for future changeout once the signalling system is renewed in the future.

The turnouts shall be checked for wear and any refurbishment work shall be undertaken by the Contractor. The places where the wear-out stage of the switch is measured, are marked with points. The wear-out for the rails of the switch is measured with mould/pattern. The mould consists of a glider with supports to the rail head, and profile E, which measures the way of tongue wear-out.

Measurement is according to the following schemes.

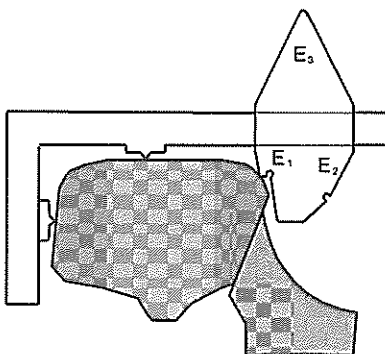

Profile E₁ is used for checking of the upper edge of the tip of the tongue, and it should not touch the mould/pattern. If this is not achieved, the tip of the tongue has to be grinded at length not less than 50 mm with gradual transition or the tongue has to be replaced.

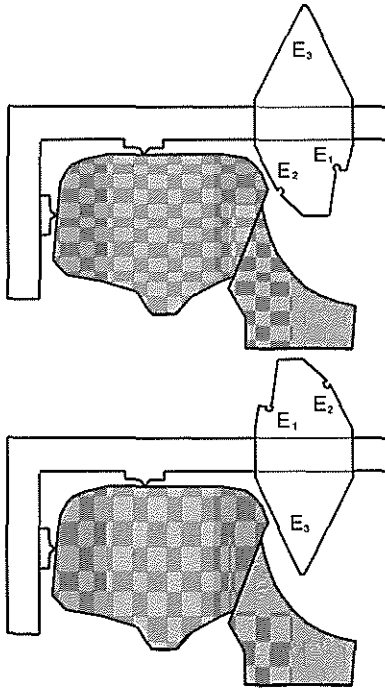

Profile E₂ is used for checking of the lateral surface from the tip of the tongue to section 40 mm, and it should not touch the area under the cut. If the surface touches the area under the cut at distance more than 200 mm from the tip, the tongue shall be replaced. When the touching length is less than 200 mm, the tongue shall be grinded at angle 60° with gradual transition. Check with mould E₃ shall be carried out.

Profile E₃ is used for checking of the incline of the lateral surface of the tongue, and the requirement is that the surface should not touch the mould.

o) Technical Backfill approach between Embankment and Abutment

The Contractor shall take particular consideration for the track interface between the tracks to abutment/bridge deck to prevent settlement. Between the Railway Bridge and the Earthwork, the transitions are required to transfer any change in track modulus due to differential settlement differences (see illustration below):

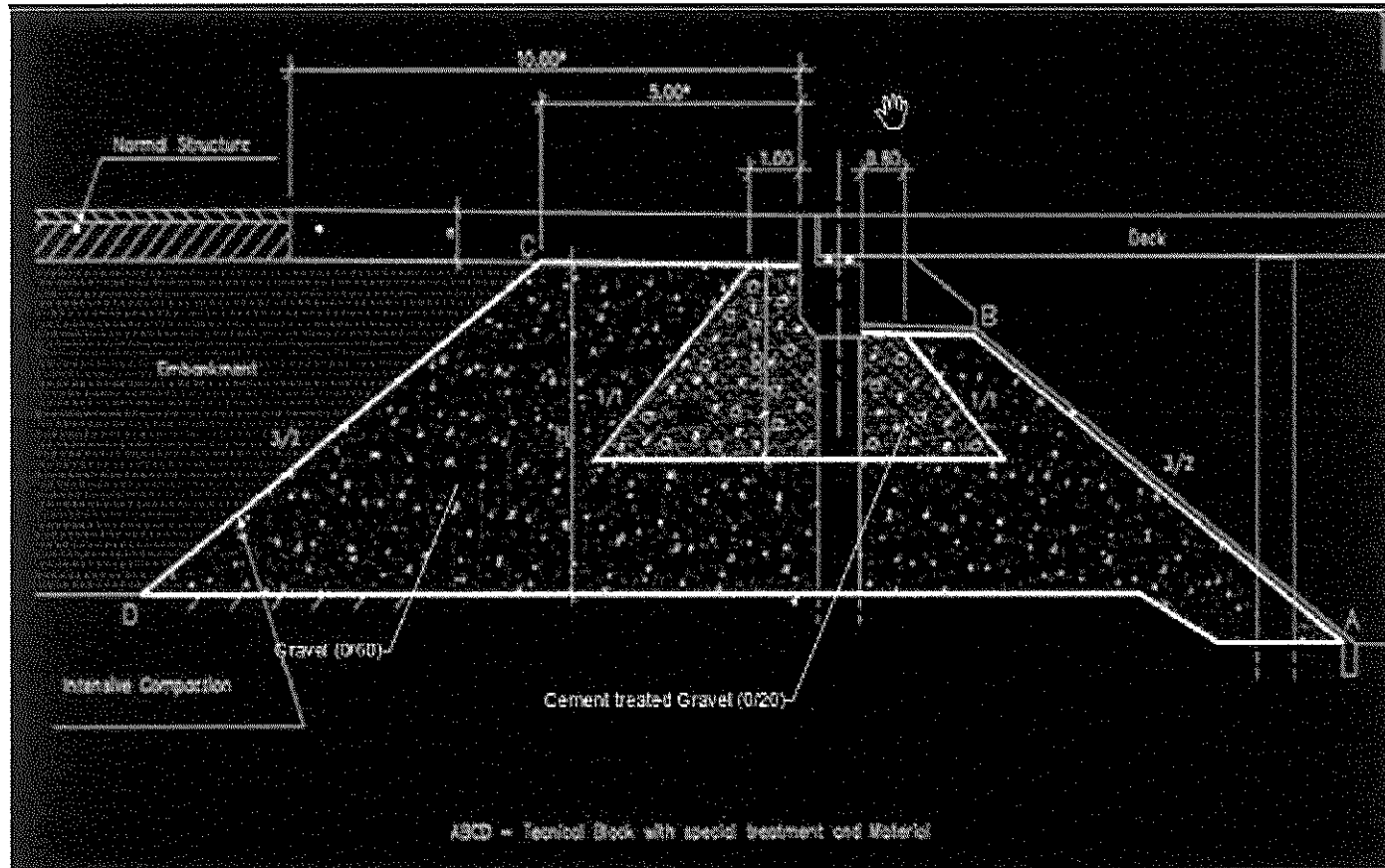

The Design Report for bridges shall detail the arrangement proposed for the management of the change of track modulus at the approaches to bridges so as to minimise any settlement and ongoing maintenance problems.

Typical arrangement for the approach to a bridge that needs to be incorporated into the Contractor's design....

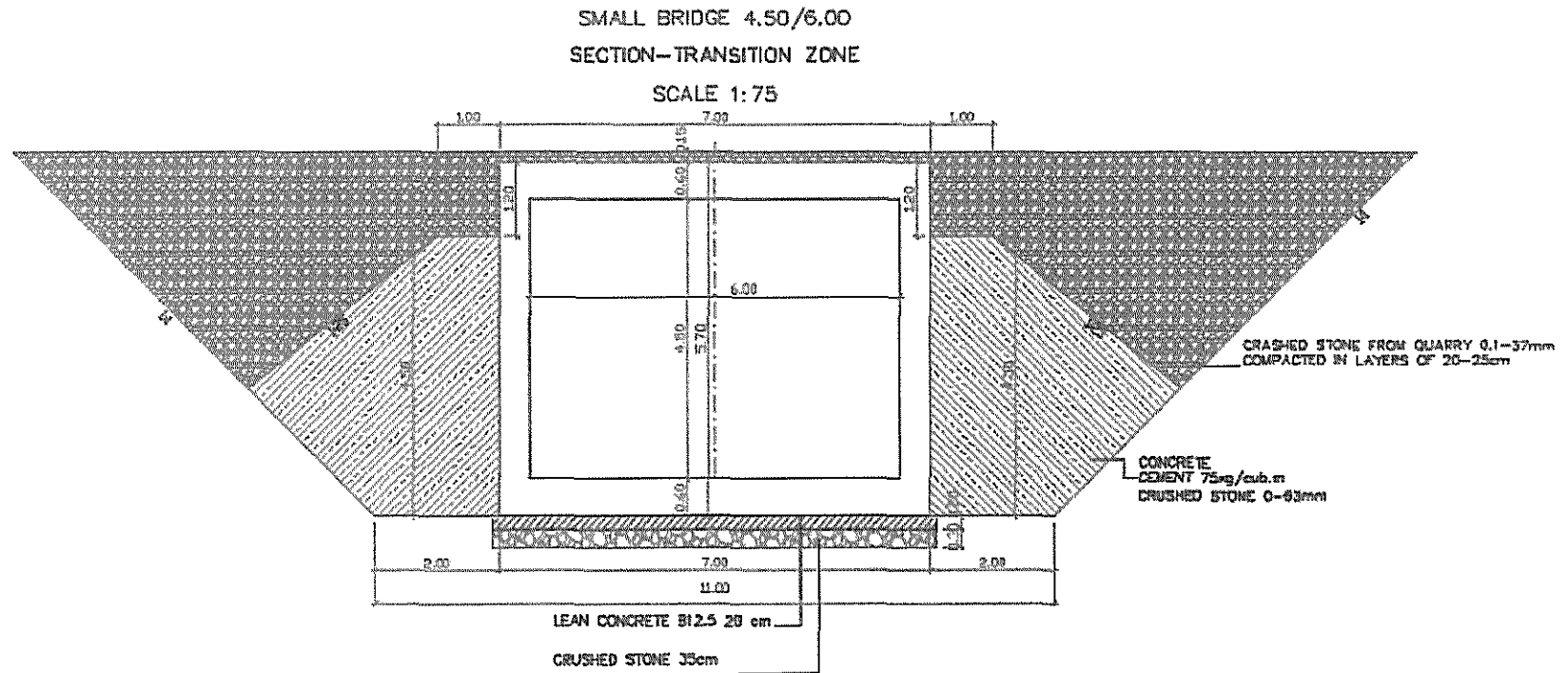

p) Signalling Cable Ducts

Cable ducts shall be installed at locations as defined by the interfacing Signalling Contractor – Refer Employer’s Requirements PART 3, Clause 5.2 Signalling Interface – Cable Ducts. Details of the ducts to be installed are shown in the figures below.

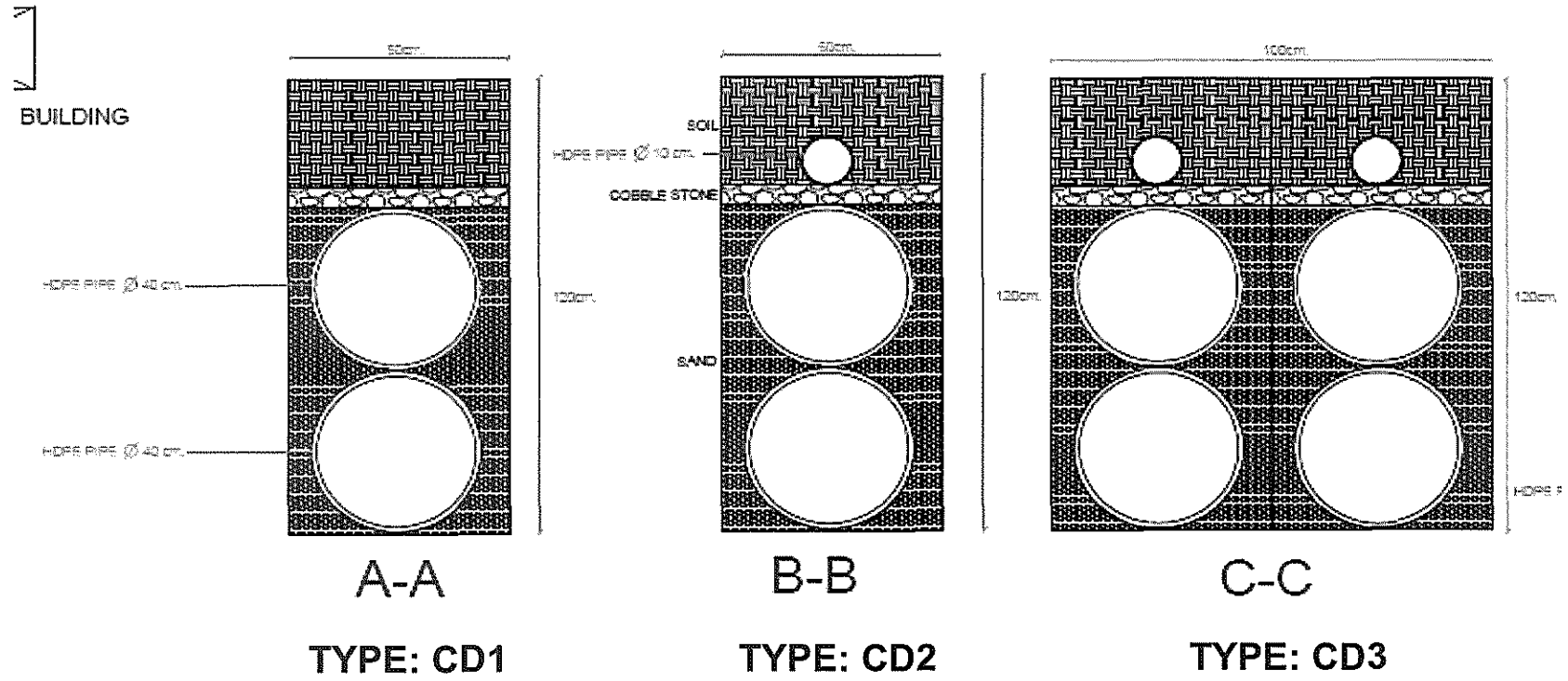

CABLE DUCTS IN STATIONS

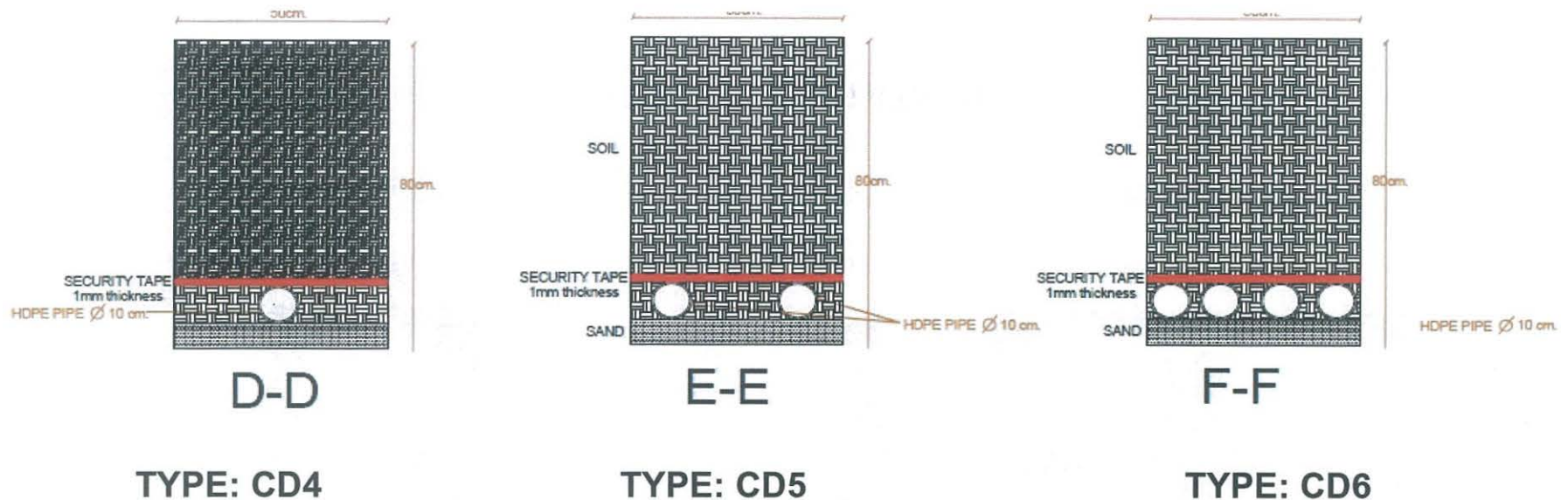

(Note: All Ducts 600mm wide trench)
CABLE DUCTS – GENERAL

CABLE PITS

The Contractor shall design and install suitable Cable Pits. Cable pits are required for the following:

- i. Cable Access & Pulling Pits
- ii. Cable Turning Pits
- iii. Cable Jointing Pits
- iv. Cable Termination Points/Pits

- Cable ducts, and cable pits shall conform to UIC Leaflet 755-1: 1969 AMD1
- The tops of cable pits shall be flush with the ballast top.
- The height of cable entries and ducts shall be such that the cable is at least 300mm above the floor of the pit at the entry.
- All Cable Pits shall have tight fitting covers & load capacity 2kN
- The cable pit sizing shall allow for a 96 core Optical Fibre cable
- Where ducts enters a cable pit, the ducts or ground line troughing shall be encased in concrete for a distance of 300 mm from the pit

Layout of Bash Sumgayit station

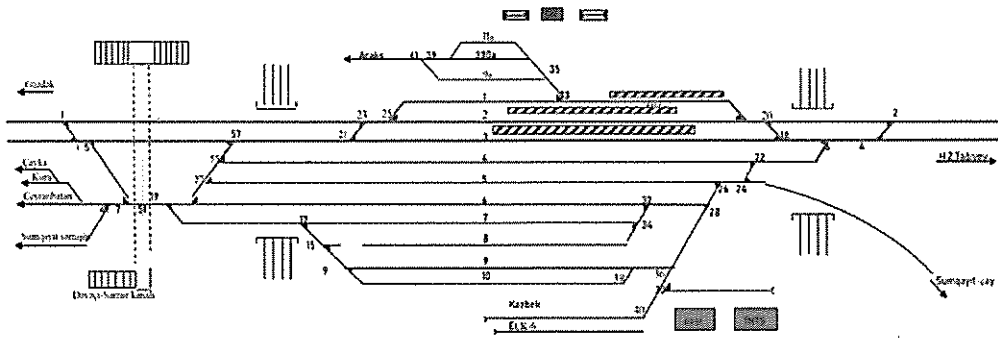

Track #	Turnout #	Type	Direction	Status	Yolun tarix uzunluðu (m)
1	33	1/9.	right	refurbished	851
2	1	1/11 cwr	right	new	
2	23	1/11 cwr	left	new	
2	25	1/11 cwr	left	new	
2	16	1/11 cwr	right	new	
2	20	1/11 cwr	right	new	
2	2	1/11 cwr	left	new	1049
3	3	1/11 cwr	right	new	
3	5	1/11 cwr	right	new	
3	57	1/11 cwr	left	new	
3	21	1/11 cwr	left	new	
3	18	1/11 cwr	right	new	
3	6	1/11 cwr	left	new	1187
3	4	1/11 cwr	left	new	
4	55	1/11.	left	refurbished	1187
4	22	1/11.	left	refurbished	

- *CWR- Continuous welded rails
- *Complete new tracks = Track N2 & 3
- *Tracks rehabilitated with re-used components= Track N1 & 4
- *New Turnouts 1/11 CWR = 13u
- *Refurbished Turnouts 1/11 = 2u
- *Refurbished Turnouts 1/9 = 1u

Layout of Haji Zaynalabdin Tagiyev station

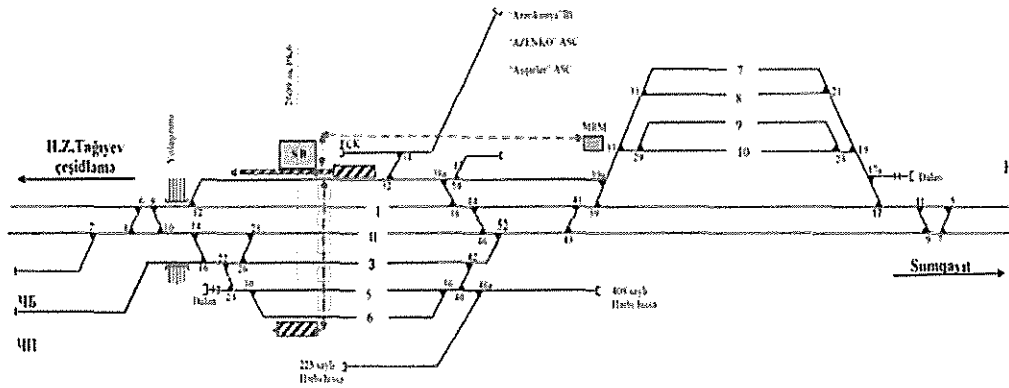

Track #	Turnout #	Type	Direction	Status	Total length of track (m)
1	6	1/11 cwr	left	new	1050
1	8	1/11 cwr	right	new	
1	12	1/11 cwr	left	new	
1	38	1/11 cwr	right	new	
1	44	1/11 cwr	right	new	
1	41	1/11 cwr	left	new	
1	39	1/11 cwr	left	new	
1	17	1/11 cwr	right	new	
1	11	1/11 cwr	right	new	
1	5	1/11 cwr	left	new	
2	4	1/11 cwr	left	new	1240
2	10	1/11 cwr	right	new	
2	14	1/11 cwr	right	new	
2	28	1/11 cwr	left	new	
2	46	1/11 cwr	right	new	
2	52	1/11 cwr	left	new	
2	43	1/11 cwr	left	new	

Track #	Turnout #	Type	Direction	Status	Total length of track (m)
2	9	1/11 cwr	right	new	1240
2	7	1/11 cwr	left	new	
2	2	1/11 cwr	left	new	
3	16	1/11	right	refurbished	1170
3	22	1/11	right	refurbished	
3	26	1/11	left	refurbished	
3	42	1/9	left	refurbished	1200
4	32	1/9	left	refurbished	
4	38a	1/11	right	refurbished	
4	54	1/9	left	refurbished	
4	39a	1/9	left	refurbished	

- *CWR- Continuous welded rails
- *Complete new tracks = Track N1 & 2
- *Tracks rehabilitated with re-used components= Track N3 & 4
- *New Turnouts 1/11 CWR = 20u
- *Refurbished Turnouts 1/11 = 4u
- *Refurbished Turnouts 1/9 = 4u

All Tracks and turnouts shown are those that are required at Yasma Station. All other tracks and turnouts are to be completely dismantled, cleaned and returned to ADY store.

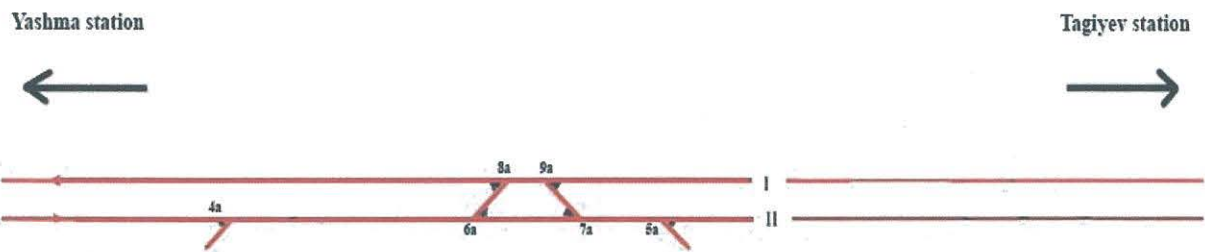

Track #	Turnout #	Type	Direction	Status	Total length of track (m)
1	8a	1/11 cwr	left	new	
1	9a	1/11 cwr	right	new	
2	4a	1/11 cwr	left	new	
2	6a	1/11 cwr	left	new	
2	7a	1/11 cwr	right	new	
2	5a	1/11 cwr	right	new	

*CWR- Continuous welded rails
 *Complete new tracks = Track N1 & 2
 *New Turnouts 1/11 CWR = 6u

Track #	Turnout #	Type	Direction	Status	Total length of track (m)
1	4	1/11 cwr	left	new	954
1	6	1/11 cwr	left	new	
1	7	1/11 cwr	right	new	
1	3	1/11 cwr	right	new	
2	2	1/11 cwr	left	new	924
2	10	1/11 cwr	right	new	
2	5	1/11 cwr	left	new	
2	1	1/11 cwr	right	new	
3	8	1/11.	left	refurbished	728
3	13	1/9.	right	refurbished	
3	9	1/11.	right	refurbished	
4	15	1/11.	right	refurbished	924

- *CWR- Continuous welded rails
- *Complete new tracks = Track N1 & 2
- *Tracks rehabilitated with re-used components= Track N3 & 4
- *New Turnouts 1/11 CWR = 8u
- *Refurbished Turnouts 1/11 = 3u
- *Refurbished Turnouts 1/9 = 1u

Layout of Gilazi station

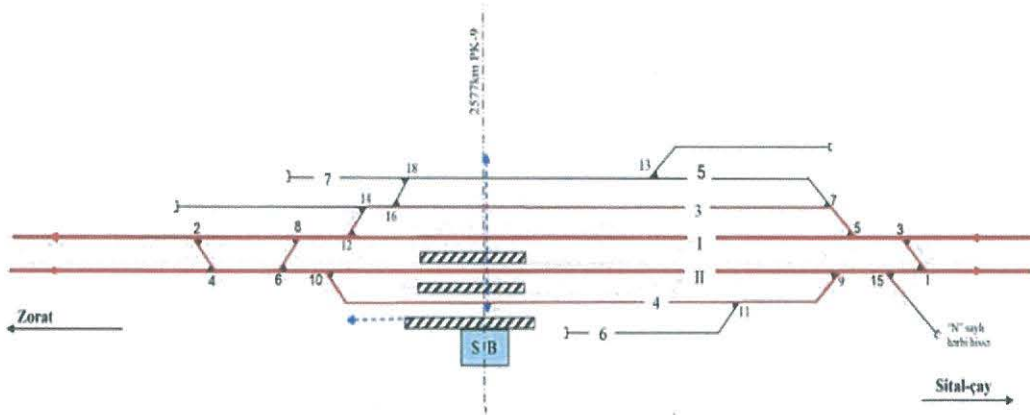

Track #	Turnout #	Type	Direction	Status	Total length of track (m)
1	2	1/11 cwr	right	new	988
1	8	1/11 cwr	left	new	
1	12	1/11 cwr	left	new	
1	5	1/11 cwr	right	new	
1	3	1/11 cwr	right	new	
2	1	1/11 cwr	right	new	1037
2	4	1/11 cwr	right	new	
2	6	1/11 cwr	left	new	
2	10	1/11 cwr	right	new	
2	9	1/11 cwr	left	new	
2	15	1/11 cwr	right	new	
3	7	1/11.	left	refurbished	858
3	16	1/9.	left	refurbished	
3	14	111	left	refurbished	

Track #	Turnout #	Type	Direction	Status	Total length of track (m)
4	11	1/9.	left	refurbished	968

- *CWR- Continuous welded rails
- *Complete new tracks = Track N1 & 2
- *Tracks rehabilitated with re-used components= Track N3 & 4
- *New Turnouts 1/11 CWR = 11u
- *Refurbished Turnouts 1/9 = 2u
- *Refurbished Turnouts 1/11 = 2u

Layout of Zarat station

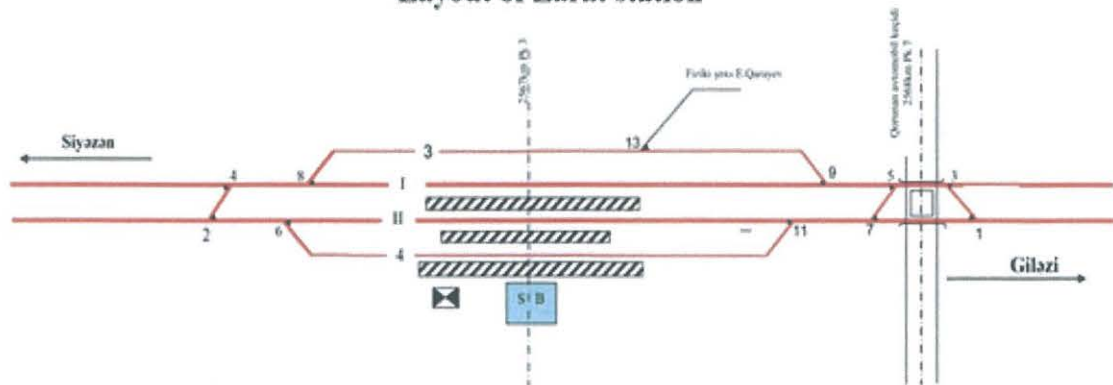

Track #	Turnout #	Type	Direction	Status	Total length of track (m)
1	4	1/11 cwr	left	new	929
1	8	1/11 cwr	left	new	
1	9	1/11 cwr	right	new	
1	5	1/11 cwr	left	new	
1	3	1/11 cwr	right	new	
2	2	1/11 cwr	left	new	963
2	6	1/11 cwr	right	new	
2	11	1/11 cwr	left	new	
2	7	1/11 cwr	left	new	
2	1	1/11 cwr	right	new	
3	13	1/9	left	refurbished	929
4	-	-	-	-	963

*CWR- Continuous welded rails

*Complete new tracks = Track N 1 & 2

*New Turnouts 1/11 CWR = 10u

*Tracks rehabilitated with re-used components= Track N3 & 4

*Refurbished Turnouts 1/9 = 1u

Layout of Siyazan station

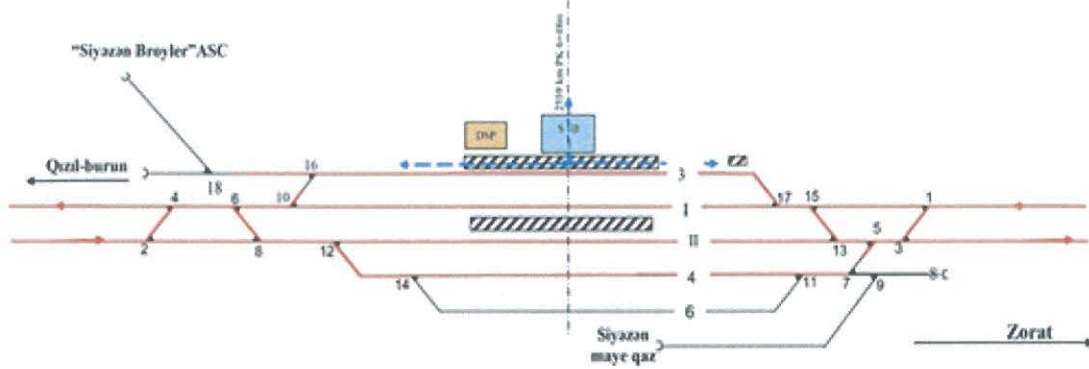

Track #	Turnout #	Type	Direction	Status	Total length of track (m)
1	4	1/11cwr	left	new	897
1	6	1/11cwr	right	new	
1	10	1/11cwr	left	new	
1	17	1/11cwr	right	new	
1	1	1/11cwr	left	new	
1	15	1/11cwr	right	new	
2	5	1/11cwr	left	new	954
2	3	1/11cwr	left	new	
2	13	1/11cwr	right	new	
2	12	1/11cwr	right	new	
2	8	1/11cwr	right	new	
2	2	1/11cwr	left	new	
3	16	1/11.	left	re-furbished	894
3	18	1/11.	right	re-furbished	

Track #	Turnout #	Type	Direction	Status	Total length of track (m)
4	14	1/11	right	re-furbished	850
4	11	1/11.	left	re-furbished	
4	7	1/11.	left	re-furbished	
4	9	1/11.	left	re-furbished	
4	3	1/11.	left	re-furbished	

- *CWR- Continuous welded rails
- *Complete new tracks = Track N1 & 2
- *Tracks rehabilitated with re-used components= Track N3 & 4
- *New Turnouts 1/11CWR = 12u
- *Re-furbished Turnouts 1/11 = 6u

Layout of Gizilburun station

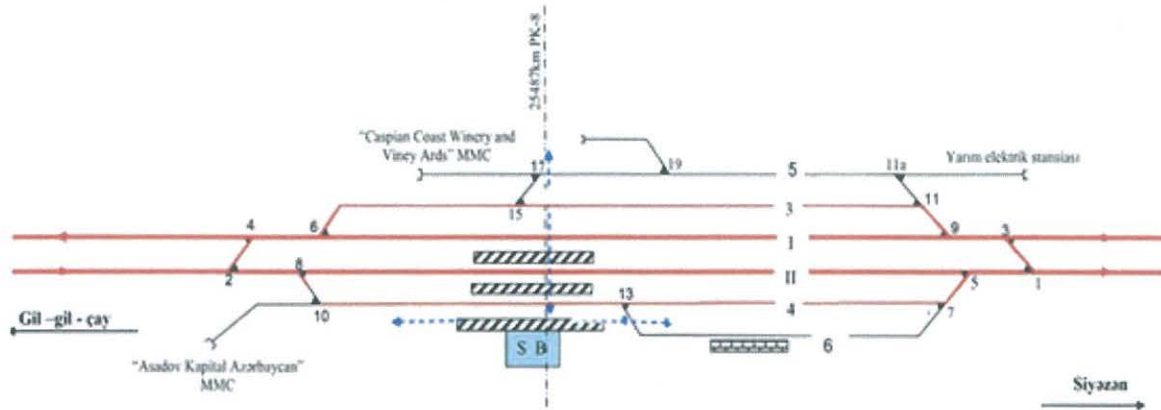

Track #	Turnout #	Type	Direction	Status	Total length of track (m)
1	4	1/11 cwr	left	new	921
1	6	1/11 cwr	left	new	
1	9	1/11 cwr	right	new	
1	3	1/11 cwr	right	new	
2	2	1/11 cwr	left	new	1103
2	8	1/11 cwr	right	new	
2	5	1/11 cwr	left	new	
2	1	1/11 cwr	right	new	
3	11	1/11	right	refurbished	874
3	15	1/11	left	refurbished	
4	7	1/11	left	refurbished	1013
4	13	1/11	right	refurbished	
4	10	1/11	right	refurbished	

*New Turnouts 1/11 CWR = 8u

*Complete new tracks = Track N1 & 2

*CWR- Continuous welded rails

*Refurbished Turnouts 1/11 = 5u

*Tracks rehabilitated with re-used components= Track N3 & 4

All Tracks and turnouts shown are those that are required at Gil-Gil-Cay Station. All other tracks and turnouts are to be completely dismantled, cleaned and returned to ADY store.

Layout of Gilgilchay station

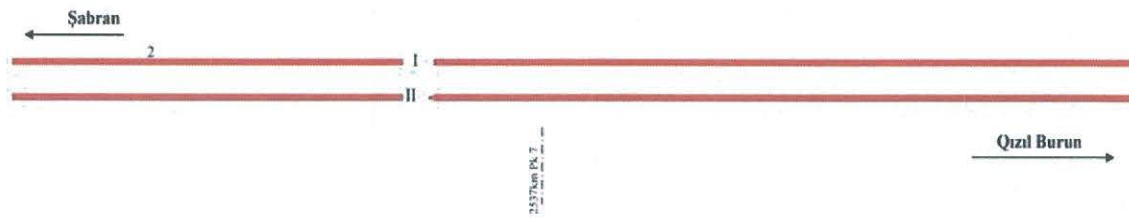

*CWR- Continuous welded rails

*Complete new tracks = Track N1 & 2

The table below sets out details of locations of turnouts and track lengths for Tracks 3 & 4 in stations.

Lot 1 Location		On Track №1 & 2			Total	Total length of track 3+4
Station	Km	Number of turnouts in cross-over (type 1/11)		Turnouts type 1/9		
		Unit	Qty	Qty	Qty	m
GIL GIL CHAY	2537.700	0.00	0.00	0.00	0.00	
QIZIL BURUN	2548.709	8.00	8.00	0.00	8.00	1887
SIYAZAN	2559.648	12.00	12.00	0.00	12.00	1744
ZARAT	2568.881	10.00	10.00	0.00	10.00	1892
GILAZI	2578.956	11.00	11.00	0.00	11.00	1826
SITAL CHAY	2589.756	8.00	8.00	0.00	8.00	1652
YASMA	2598.600	3.00	3.00	0.00	3.00	0
YASMA-TAGIYEV	TBA	6.00	6.00	0.00	6.00	0
H.Z.TAGIYEV	2610.593	20.00	20.00	0.00	20.00	2370
SUMQAYIT BAS	2620.818	13.00	13.00	0.00	13.00	2236
		Operational Spares	4.00	0.00	4.00	
		Totals	95.00	0.00	95.00	13,607

Appendix 2

LOT1

SCHEDULE OF DATES & MILESTONES

SCHEDULE OF DATES & MILESTONES

General

The time frame, access and possession criteria for Lot 1 Works are set out below:

Overall Timeframe to Completion: 1280 Days from Date of Commencement

Access to & possession of the Site: 14 Days after Date of Commencement

While access and possession of the Site shall be granted pursuant to GCC Sub-Clause 2.1 as set out above, where such access and possession is for the Contractor to undertake all activities to enable the design to be undertaken, completed, submitted, reviewed and have a Notification of No Objection issued for the Definitive Design and Drawings.

Sections: A Section consists of three (3) Spans.
A Span consists of the main line tracks and turnouts between stations, and may include at stations the two main line tracks (Right Track & Left Track) and the connected two parallel tracks Track 3 & Track 4 in the station area.

Summary of Sections:

There are three (3) Sections in Lot 1 as follows:

Section 1: Sumqayıt baş to Yasma

Section 2: Yasma to Zarat

Section 3: Zarat to Gil-Gil Cay

Note: The limits for Sections is set out in Appendix 2: Table 1 below.

Once the Definitive Design and Drawings for a Section have been accepted and a Notification of No Objection issued to the Contractor then construction and rehabilitation Works can commence in those locations applicable to the accepted design.

Track Possessions:

Access to and possession of the Site shall be granted as set out above, thereafter pursuant to GCC Sub-Clause 4.13, the Employer shall also provide special and/or temporary rights of way which are necessary for the Works to proceed, in the form of Track Possessions, where parts of the track are temporarily taken out of operational service to permit the Contractor to undertake works that require no trains to pass.

A Track Possession shall be made available to the Contractor only after Completion of Definitive Design & Drawings and a Notification of No Objection has been received for that applicable Section.

Track Possessions are proposed to be granted to the Contractor sequentially on six occasions, i.e. two (2) in each Section. The sequence of Track Possessions and location is fixed by the Employer.

Track Possession periods will on average be 155 days each, within the overall contract period, and dependent on the Contractor's programme requirements.

Only one (1) of the Track Possessions as set out below, shall be granted at any one time.

Details of Track Possessions by Section are set out in Appendix 2, Table 1 below.

APPENDIX 2 – TABLE 1: Track Possessions by Section for Lot 1

Sequence No.	Section	Track	Possession Number
1	Section 1	Right Track	1R
2	Section 1	Left Track	1L
3	Section 2	Left Track	2L
4	Section 2	Right Track	2R
5	Section 3	Right Track	3R
6	Section 3	Left Track	3L

Diagram 1 below shows how the six (6) Track Possessions will be applied in sequence. Track Possessions are shown as the blacked-out parts on the diagram.

APPENDIX 2 – DIAGRAM 1 - Sections & Track Possessions for Lot 1

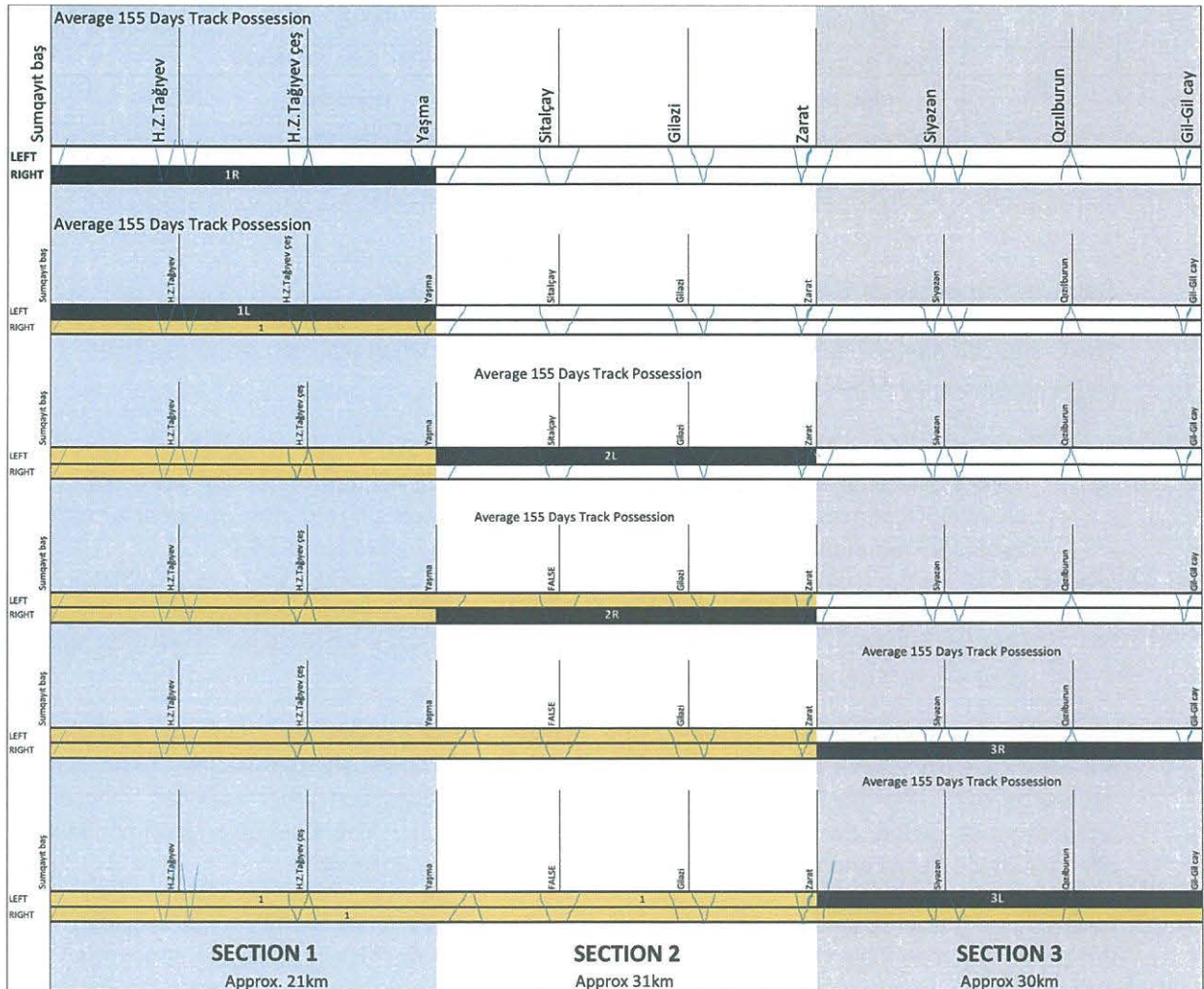

Any Track Possession shall include one only of the two main line tracks (i.e. either Left Track or Right Track) between possession limits. One of the main lines and one of Track 3 or Track 4 shall be granted Track Possession in stations dependent on possession limits.

During the Track Possession period in a Section, the adjacent main line track will be operating ADY train traffic bi-directionally.

The limits for each Section and for Track Possession are set out in Table 2 below.

APPENDIX 2: TABLE 2 –Section Limits and Track Possession Limits for Lot 1

Possession Number	Location	Starting Point	Ending Point	Notes
1R	Sumgayit to Yasma (Right Track)	Sumgayit t/out No.3 (included)	Yasma t/out No.7 (excluded)	The crossovers at the Baku end of Yasma (t/outs 1, 3, 5, & 7) to remain in service until Possession 1R, 1L completed, then remove crossovers.
1L	Sumgayit to Yasma (Left Track)	Sumgayit t/out No.1 (included)	Yasma t/out No.3 (excluded)	
2L	Yasma to Zarat (Left Track)	Yasma t/out No.5 (excluded)	Zarat t/out No.7 (excluded)	Work on Level Crossing between t/outs 5 & 3 on Right track to include rehabilitation of track between t/outs 5 & 3 and renewal of t/outs No.5 & 3
2R	Yasma to Zarat (Right Track)	Yasma t/out No.1 (excluded)	Zarat t/out No.3 (excluded)	
3R	Zarat to Gil-Gil Cay (Right Track)	Zarat t/out No.5 (excluded)	Gil-Gil Cay t/out No. 2 (excluded)	
3L	Zarat to Gil-Gil Cay (Left Track)	Zarat t/out No.7 (included)	Gil-Gil Cay t/out No. 6 (excluded)	

Section Possession Requirements

The Contractor needs to take into account the following issues when planning the Works to be undertaken during a Track Possession:

- i. Temporary turnouts, with signalling, may need to be installed at certain locations to permit the Track Possession to operate successfully, i.e. permitting ADY train operations to continue, and allow the Contractor access to all the Works areas. There is no separate payment for signalled temporary turnouts, and it is deemed to be included as part of the Works.
- ii. ADY train access to H.Z. Tagiyev Depot is required at all times, and hence temporary signalled turnouts and other arrangements shall be implemented by the Contractor at the entry and exit locations of the Depot to permit the required access.

After each Track Possession has ended in a Section, the Contractor shall allow, on that Section, temporary use of the track until the Taking-Over Certificate (GCC Clause 10) is issued. Temporary use will be by ADY and interfacing contractors, for train operations and other activities. During the temporary use period, train speeds shall be limited to 80km/hr. The Contractor shall continuously ensure that the track condition can safely sustain this temporary speed limit.

Following a Track Possession in a Section, the Contractor's work activities not requiring Track Possessions are permitted to continue in that Section on the infrastructure, including structures.

Work on or near the track without a Track Possession is restricted by ADY operations and safety procedures. Work undertaken on or near the track will require the Contractor to comply with all ADY safety and operational procedures.

The Contractor shall ensure the safety of the trains, the Works and personnel, at all times.

Sectional Completion

The Contractor shall programme the Works to ensure that each Section is completed in accordance with Clause 10 of the GCC as follows:

Section 1: 930 days from Date of Commencement

Section 2: 1105 days from Date of Commencement

Section 3: 1280 days from Date of Commencement

To achieve a Taking-Over Certificate pursuant to GCC Clause 10, for any Section, it shall be necessary to complete all of the Works in that Section to the satisfaction of the Engineer. This shall include the satisfactory passing of all Tests on Completion, submission and acceptance of As-Built Drawings, and the Skim Grinding completed. Additionally, the Act of Reception of Works is required to be issued as set out in PCC, Section 8, Part B, Clause 10.1.

Locations of Works

Table 3 below sets out the locations of specific works to be undertaken in Lot 1. This is provided to assist the Bidder/Contractor in appreciating the scope of work and to gain an understanding of where the works are located so that the works can be planned.

APPENDIX 2 TABLE 3: – Locations Of Specific Works for Lot 1

SPAN	Length	Bridges								Culvert					
		less 25 m				more 25 m				Grand Total	Cap.rep	Repair	Replace	Grand Total	
Cap.rep	Repair	Replace	Nil Work	Cap.rep	Repair	Replace	Nil Work	Cap.rep	Repair						Replace
1. Sumqayıt baş - H.Z.Tağıyev	10			7		2					9	2	2	2	6
left				4		1					5	1	1	1	3
right				3		1					4	1	1	1	3
2. H.Z.Tağıyev - H.Z.Tağıyev çeş.	7										0		4	8	12
left											0		2	4	6
right											0		2	4	6
3. H.Z.Tağıyev çeş. - Yaşma	4			4							4			2	2
left				2							2			1	1
right				2							2			1	1
4. Yaşma - Sitalçay	10					1		1			2			6	6
left								1			1			3	3
right						1					1			3	3
5. Sitalçay - Giləzi	11	1		3		2	1				7	2		10	12
left		1		2		1					4	1		5	6
right				1		1	1				3	1		5	6
6. Giləzi - Zarat	10			3							3			10	10
left				2							2			5	5
right				1							1			5	5
7. Zarat - Siyazan	9	2		2							4			10	10
left		1		1							2			5	5
right		1		1							2			5	5
8. Siyazan - Qızılburun	11	4		2				2			8			12	12
left		2		1				1			4			6	6
right		2		1				1			4			6	6
9. Qızılburun - Gil-Gilçay	10			6		2		2			10		2	25	27
left				2				2			4		1	12	13
right				4		2					6		1	13	14
Total for LOT1	82	7	0	27	0	7	1	5	0	47	4	8	85	97	

Approximate kilometrage of stations is set out in Table 4 below:

APPENDIX 2 – TABLE 4 Approximate Station Km

1. Sumqayıt baş - 2. H.Z.Tağıyev	2620 - 2610
2. H.Z.Tağıyev - 3. H.Z.Tağıyev çeş.	2610 - 2603
3. H.Z.Tağıyev çeş. - 4. Yaşma	2603 - 2599
4. Yaşma - 5. Sitalçay	2599 - 2589
5. Sitalçay - 6. Giləzi	2589 - 2578
6. Giləzi - 7. Zarat	2578 - 2568
7. Zarat - 8. Siyəzən	2568 - 2559
8. Siyəzən - 9. Qızılburun	2559 - 2548
9. Qızılburun - 10. Gilgilçay	2548 - 2538

APPENDIX 3

DESIGN AND CONSTRUCTION INTERFACES

1. INTERFACES

- (1) The Contractor shall interface the Design (designing, obtaining of design and utility approvals and permits for construction) and Construction/Manufacturing and Supply and Installation-Testing -Commissioning Phases of the Works with that of other Contractors, principally the Contractors for the interfacing parties as defined in the Conditions of Contract.
- (2) The Contractor shall keep the Engineer fully informed in respect of such interfaces, such information being given to the Engineer in a manner and form and at such intervals as stated in the Contract or as required by the Engineer.
- (3) The interfacing parties for this Contract include but are not limited to:
 - a) Contracts for implementation of Civil & Track – The Contract for Lot 2, provides for design and construction of the civil, track for Tracks N°1 & 2 between Yalama (Russian border and Gil-Gil-Chay (km 2358,200) and in particular on the border between LOT1/LOT2, at km 2358,200 approximately. The works are similar to the works to be carried out under the present contract and include the design and construction of the permanent way, culverts and bridges and supply, installation and commissioning of the track work.
 - b) Existing Railway Operation: Operation of the existing railway line is under the control of ADY and the Contractor will be responsible for coordinating with ADY Freight Dept. to obtain possession of the railway envelope.
 - c) Electrification and power supply Contractors, adjusting and upgrading the exiting catenary system and installing and switching the power system from 3kV DC to 25kV AC, 50Hz
 - d) Signalling Contractor, adjusting and upgrading the signalling systems or parts thereof.

2. INTERFACE RESPONSIBILITIES

- (1) The responsibility for specification and provision of the requirements for the works which interface with interfacing parties' equipment are tabulated below.
- (2) This Appendix shall be read in conjunction with the relevant clauses of the Technical Requirements - Part 1 General and the Contractor shall be responsible for ensuring that all interfaces are properly co-ordinated.
- (3) This Appendix outlines the interfacing requirements during the execution of the Works, however the requirements specified herein are by no means exhaustive and it remains the Contractor's responsibility to develop, update and execute jointly an Interface Management Plan after the beginning of the Works and throughout the execution of the Works to ensure that:
 - a) All interface issues between the Contractor and the interfacing parties are satisfactorily identified and resolved; and
 - b) All the construction tolerances at the interface' shall meet the requirements of the respective specifications relating to the interface points.
- (4) Where details of the Design are required to enable the Interfacing Party to implement interface works, the Contractor shall provide the interfacing parties with the necessary information including, but not limited to, those described in the summary table appended to this requirement, the level of information provided shall be in sufficient detail to enable the interfacing parties to design and / or construct the required interface works.

- (5) The Contractor shall take a lead in developing the Interface Management Plan (IMP), the IMP will be prepared in conjunction with the interfacing parties to cover all aspects of the implementation of the interface works required.
- (6) The IMP will define the interface works necessary to complete all the works in this contract and is not limited to those listed in the summary table attached.
- (7) The IMP shall conform to the Works Programme and shall, in respect of the Works by the Contractor and each of the Interfacing Parties, show and be in logical agreement with Key Dates and Works Areas Hand-over Date on completion of the Contract.
- (8) The IMP shall indicate dates for the beginning and completion of each principal activity on the Site by each Contractor, and delivery and installation of principal items of equipment.
- (9) The IMP shall be submitted by the Contractor to the Engineer, in a preliminary form, within sixty (60) days of the Date of Commencement or any Interfacing Contract whichever is the later, thereafter, the IMP shall be updated by the Contractor at regular intervals of not exceeding twenty-eight (28) days, agreed with interfacing parties and submitted to the Engineer.
- (10) Should it appear to the Engineer that the progress of the Works, Works Programme or the Three-Month Rolling Programme does not conform to the IMP, the Contractor shall be required to revise all such programmes and plans such that they do reflect the progress of the Works, are mutually consistent and conform to other provisions of the Contract.
- (11) The Contractor shall review the details of interface works and notify the Engineer of any amendments to the summary table required in the process of his works. Unless such requests are reviewed without objection by the Engineer, the Contractor shall construct the works in accordance with the provisions outlined in this Appendix and the attached summary table.

2. SCOPE OF WORK OF THE INTEGRATED MANAGEMENT PLAN

- (1) The interface scope of works to be provided by the Contractor includes but are not limited to those outlined in the summary below. This only outlines the interface point and various stakeholders and is not a complete itemisation of the Scope of Work.

INTERFACE POINTS & STAKEHOLDERS

INTERFACING PARTIES	NOTES
ADY Freight Dept.	For all Track Possessions
ADY Infrastructure Dept.	For all OCS outage
ADY Infrastructure Dept.	For all Signalling outage
ADY Infrastructure Dept.	All infrastructure Details
ADY Infrastructure & Property Depts.	All cadastral details
ADY Infrastructure & Property Depts.	All property details
ADY Infrastructure	Storage and return of materials
OCS Contractor	Design & installation of new OCS (with new support structures)
Signalling Contractor	Design and Installation of new signalling system
Ministry of Ecology and Natural Resources (MENR)	All environmental matters
Local Municipalities	Work in the municipality; Public road access requirements; Pedestrian overpass issues.
Various Azerbaijan Authorities	Need to comply with the Laws and authority requirements.

- (2) The interfacing parties shall be liaised by the Contractor in the Design preparation, the installation, testing, commissioning and acceptance of the works. i.e. The Contractor takes the lead.
- (3) The Contractor shall provide all access and attendance necessary in accordance with the contract requirements to enable the interfacing parties to complete those activities defined under the summary table attached to this interface specification in a timely manner, such access and attendance shall include the provision of lighting for the works where available and safety provisions such as safe access and egress to all parts of the works required to complete the survey and marking out works for a limited number interfacing Party's staff.
- (4) The Contractor shall also provide the interfacing parties with the main survey control data.
- (5) Where the Contractor's works are assessed by Engineer as failing to meet the requirements of the Contract and which will impact the Interfacing Party's works, the Contractor shall submit the proposed remedial measures to the Engineer for review and shall copy the same to the Interfacing Parties.

3. INTERFACE SPECIFICATION OF THE CONTRACTOR AND ADY OPERATING RAILWAY

4.1 RESPONSIBILITIES of the CONTRACTOR

- (1) The Contractor shall be responsible for requesting Track Possessions in accordance with the Programme that complies with the Contract, for work and the Contract provisions in timely manner.
- (2) The Contractor shall bear full responsibility for providing suitable infrastructure and safety conditions for railway traffic along the whole of the line included in the Contract during the contract performance.
- (3) With regards to every particular case he shall provide for temporary signalling and telecommunication systems to maintain the safety of traffic and shall perform all the necessary works related therewith, such works shall include, but not be limited to:
 - a) Provision of protection of the main and station signalling and telecommunications cables against damage and high-voltage interference, this may be done by re-using the existing equipment and re-positioning of the existing cables to the outside the working zone, or by using new ones as temporary measure, or any other suitable measures, subject to agreeing with ADY and approval by the Engineer;
 - b) The temporary means and measures provided by the Contractor as stated above, shall include possibility for electrical operation and control of the new turnout motors, supplied with the turnouts themselves, control of any temporary or permanent entry and warning signals, power supply;
 - c) Provision of cables and telecommunication systems for connection between the station foreman and the signalmen in the stations
- (4) Any equipment/materials/systems provided by the Contractor in fulfilling the above obligations, after the completion of the Contract shall be used by the Employer for ensuring of normal traffic operations.
- (5) The Contractor shall provide for any speed restrictions and specific traffic conditions and shall be responsible for recommending to ADY their imposition/cancelling (subject to approval by the Engineer).

- (6) In case of need for temporary changeover between the existing and new track the Contractor shall be entitled to use any materials dismantled from the existing track, such materials being in full conformity to ADY regulations for second-hand materials.
- (7) The exact quantities of the materials used for such purposes shall be agreed with the Employer and approved by the Engineer.
- (8) The Contractor shall be responsible for removal, dismantling, cleaning and transportation to a storing place, advised by the Employer, of all materials from the existing track.

4.2 RESPONSIBILITIES of the ADY

- (1) The Employer shall consider and approve the requested Track Possessions in a timely manner in accordance with the provisions stated in the Contract.
- (2) The Employer shall consult and assist the Contractor in handling the materials dismantled from the old track and in any issues related to traffic arrangements, speed restrictions, etc.

APPENDIX 4

**WORKS PROGRAMME
REQUIREMENT**

1. OUTLINE OF THE PROGRAMME

- (1) The Contractor shall submit his detailed Works Programme (Programme) to the Engineer in accordance with Sub-Clause 8.3 of the Conditions of Contract;
- (2) The Programme shall be submitted at the time of the Contractor's Preliminary Design submission (refer **Appendix 24**), reviewed and if acceptable duly approved in accordance with the contract provisions.
- (3) The Programme in any form shall not relieve the Contractor from his obligation to complete the whole of the Works within the Time for Completion in accordance with Sub-Clause 8.2 of the Conditions of Contract.
- (4) The Programme shall clearly set out, in detail, the Works to be undertaken by Section and when Track Possessions are required.
- (5) Works shall be undertaken by Section and in any order, provided all compliance issues as set out in the Employer's Requirements are fully met. Note: **Appendix 2** sets out specific issues related to Sections and work in Sections and Track Possessions, and the order in which Track Possessions shall be granted.
- (6) The Contractor shall, during the progress of the works, constantly monitor and report his progress against the Programme.
- (7) The Contractor shall include his work obligations towards existing train operations, shared Site areas and other coincident or adjacent works areas.
- (8) The Programme, and all more detailed or revised versions, shall be submitted to the Engineer for his consent in accordance with the provisions of the Conditions of Contract.

2. METHODOLOGY

- (1) The computerised Critical Path Method (CPM) network using the Precedence Diagramming Method (PDM) has been selected by the Employer as the technique for contract management system and in co-ordinating the multi-contract project. This shall also be supported by a time location diagram, e.g. TILOS.
- (2) **The Tenderer shall also employ these techniques in preparing his Tender submissions** and by the Contractor in his Design and Construction Stage submissions.
- (3) Unless otherwise agreed by the Engineer, all programs submitted by the Contractor shall be produced using computerised Critical Path Method (CPM) Networks developed implementing the Precedence Diagramming Method (PDM) with Cost Loaded Charts and Tables.
- (4) The Contractor shall implement and use throughout the duration of the Contract, a computerised system to plan, execute, maintain and manage the planning, design, preconstruction, construction, and sub-contracts in executing the CPM scheduling by PDM.
- (5) The reports, documents and data provided shall be an accurate representation of the current status of the Works and of the work remaining to be accomplished, they shall also provide a sound basis for identifying problems, deviations from the planned works, and for making decisions; and shall be prepared for timely presentation to the Engineer at Monthly Progress Meetings.

3. PROGRAMME MANAGEMENT SOFTWARE

- (1) CPM programming software used shall be by Primavera P6 and TILOS or approved alternative.
- (2) Any other compatible system capable of direct file interchange capability with software program used by the Employer can be used with Engineer's consent.
- (3) Scheduling software and relevant instruction manuals, licensed for use in connection with the contract, shall be provided by the Contractor according to the Engineer's specifications.
- (4) The Contractor may use a system other than Primavera P6 but will be required to demonstrate that full electronic data transfer is available and that the various levels of reporting and coding capabilities are at least equivalent to Primavera P6.
- (5) Compatibility and comparable performance between Primavera P6 and the Contractor's proposed system shall be demonstrated in his Tender submission.

- (6) Should compatibility not be demonstrated to the Engineer's satisfaction the Contractor shall utilise MS Project for development, updating and revision of all the Programmes during the duration of the Contract.
- (7) Upon the Engineer's consent of a system other than Primavera P6, the Contractor shall supply the Engineer with an original licensed copy, including manuals and approved training of the software and any subsequent versions thereof at no extra cost.
- (8) For time location diagrams, TILOS shall be used or another similar system as approved.

4. POST-CONTRACT AWARD

- (1) The Contractor shall develop his Works Programme including an outline Narrative Statement and submit this to the Engineer within the period stated in Sub-Clause 8.3 of the Conditions of Contract.
- (2) The Monthly Progress Reports shall also include a Programme update.
- (3) Following the Contractor's Works Programme submission but in any case, no later than two months from the date of award of contract, the Contractor shall make submissions of the detailed Works Programme suitably amended to take into account the programmes of Interfacing Contracts.
- (4) It is the Contractor's responsibility to ensure timely co-ordination with the Interfacing Contractors to revise his Programme so as not to affect the progress of Works and/or the works of the Interfacing Contractors.
- (5) For Programme submission, one (1) original, five (5) copies and one soft, operable copy of each of the following Programmes and Reports shall be submitted to the Engineer:
 - a) Programme: Baseline CPM Network;
 - b) Programme: Baseline Milestone based Cost Activity Schedule;
 - c) Time Location diagram;
 - c) Baseline Schedule Report;
 - d) Narrative;
 - e) Baseline Physical Progress curve;
 - f) Baseline Resource Charts
- (6) Notwithstanding the above, the Engineer may at any time during the course of the Contract require the Contractor to update the Programme to reflect actual activity dates and generate schedules based upon "what if" statements.
- (7) Failure to include any element of work required for performance of the Contract shall not relieve the Contractor from completing all works required under the Contract to achieve the original or any extended key completion date.

5. WORKS PROGRAMME

- (1) The Works Programme shall show the Contractor's plan for organising and carrying out whole of the Works.
- (2) The Works Programme shall be a computerised Critical Path Method (CPM) network developed using the Precedence Diagramming Method (PDM) and shall be present in bar chart and time-scaled network diagram format to a weekly or monthly time scale.
- (3) Tasks in the Works Programme shall be sufficiently detailed to describe activities and events that include, but are not limited to, the following:
 - a) Completion Dates including Key Dates, and Works Area Hand-over Dates;
 - b) Works to be undertaken in the performance of the Contract obligations;
 - c) The requested date for issue of any drawings or information by the Engineer;
 - d) Incorporation of principal aspects of the Working Drawing Submission Programme;
 - e) Procurement of major materials and the delivery and/or partial delivery date on-Site of principal items of Contractor's Equipment;
 - f) Track Possession periods (refer **Appendix 2** for Track Possession details and sequence);

- g) Any off-site work such as production or pre-fabrication of components;
 - h) Installation of temporary construction facilities;
 - i) Interface periods with Interfacing Contractors or utility undertakings;
 - j) Design, supply and/or construction activities of sub-contractors;
 - k) Any outside influence which will or may affect the Works.
- (4) The Works Programme shall show achievement of the Completion Date for each Section and Key Dates and Works Area Hand-over Dates.
- (5) Activity descriptions shall be unique, describing discrete elements of work any activity creating an imposed time or other constraint shall be fully defined by the Contractor.
- (6) The Works Programme shall be organised in a logical work-breakdown-structure for each Section including work stages and phases and shall clearly indicate the critical path(s).
- (7) The Contractor shall submit a Programme/Project Calendar cross reference clearly indicating the allowance for non-working days.
- (8) The Works Programme, in each Submission, shall be accompanied by an Activity Report and a Narrative Statement as described below in both electronic (CD-R) and hard copy format (time scale logic diagrams in A1 size, reports in A4 size).
- (9) The Activity Report shall list all activities, and events in the Works Programme, sorted by activity identification number. The Activity Report shall include the -following for each activity and event:
- a) activity identification number and description;
 - b) planned start and finish dates;
 - c) duration expressed in Days;
 - d) early and late start, & early and late finish dates.
 - e) calculated total float and free float;
 - f) predecessor(s) and successor(s), accompanying relationships and lead/lag duration;
 - g) imposed time or date constraints;
 - h) calendar,
- (10) The Narrative Statement shall be a comprehensive statement of the Contractor's plan and approach for the execution of the Works, Track Possession periods, the achievement of key dates, handover dates, submission dates and any intermediate dates incorporating outline method statements in respect of major items of work such as track removal, sub-ballast renewal, track reconstruction, bridge works, culvert works, repair works etc, including construction sequences and primary items of plant, construction equipment, temporary works and the like.
- (11) The Narrative Statement shall fully explain the reasons for the main logic Links in the Programme and include particulars of how activity duration is established, including estimated quantities, production rates, hours per shift, work days per week and a listing of the major items of Construction Equipment planned for use on the project, activities, which may be expedited by use of overtime or additional shifts, shall be identified and explained and a listing of holidays, and other special non-work days being used for the computer reports shall be included.
- (12) The Contractor shall also submit a forecast Cumulative Physical Progress curve based on the time-phased distribution of cost in the CPM Network Logic Diagram, expressed in percentage terms and generated from the computerised CPM Network Logic Diagram.
- (13) The Contractor shall also submit Baseline Resource Charts, generated from the Contractor's CPM Network Diagram, showing the anticipated manpower and main Construction Equipment usage during the execution of the Project.
- (14) As an additional monitoring facility, an indicator of resources shall be assigned to relevant activities for the major items of work.
- (15) The indicator of resources shall be directly allocated for excavation (cub. m), piling (no.), bridge construction (m²), culvert construction (m²), track work (m), etc.

- (16) Resource indicators may be input as a daily rate, expected required rate, or as an activity total in the relevant units. These are purely indicative quantities and will not form part of contract.
- (17) All submissions of proposed Works Programmes subsequently, after approval of the Initial Works Programme, shall include the actual physical progress of work and forecast of the remaining work.
- (18) Actual progress shall be stated in percent complete, remaining duration, and actual start and finish dates for each activity in the Works Programme.
- (19) The Initial Works Programme shall always remain as the baseline programme.

6. WORKS PROGRAMME REVISIONS

- (1) The Contractor shall immediately notify the Engineer in writing of the need for any changes in the Works Programme, whether due to a change of intention or of circumstances or for any other reason.
- (2) Where such proposed change affects the date for completion of the Works or any other Key Date the Contractor shall submit a revised Programme and accompanying Narrative Statement to the Engineer in accordance with Sub-Clause 8.3 of the Conditions of Contract.
- (3) The proposed revised Works Programme shall show the sequence of operations of any and all works related to the change and the impact of changed work or changed conditions.
- (4) If at any time the Engineer considers the actual or anticipated progress of the work reflects a significant deviation from the Works Programme, he may request the Contractor to submit a proposed revised Programme which together with an accompanying Activity Report and Narrative Statement, shall be submitted by the Contractor in accordance with Sub-Clause 8.3 of the Conditions of Contract.
- (5) The proposed revised Works Programme shall show the sequence of operations of any and all work related to the change and the impact of changed work or changed conditions.
- (6) The Initial Works Programme shall always be shown visibly on the revised Works Programme.

7. THREE MONTH ROLLING PROGRAMME

- (1) The Three Month Rolling Programme shall be an expansion of the current Works Programme, covering sequential periods of three months.
- (2) The Three Month Rolling Programme shall provide more detail of the Contractor's plan, organisation and execution of the work within these periods.
- (3) In particular, the Contractor shall expand each activity planned to occur during the next three (3) month period, if necessary to a daily level of detail.
- (4) The Three Month Rolling Programme shall be developed as a Critical Path Method (CPM) network and shall be presented in bar chart and time-scaled network diagram format. Bar charts shall be presented on an A4 and time-scaled networks diagrams on an A1 size reproducible media. Tasks in the programme shall be derivatives of and directly related to tasks in the approved Works Programme.
- (5) The Contractor shall describe the discrete work elements and work element inter-relationships necessary to complete all works and any separable parts thereof including work assigned to sub-Contractors.
- (6) Activity duration shall not exceed two (2) weeks unless otherwise consented to by the Engineer.
- (7) Each activity in the Three Month Rolling Programme shall be coded or described so as clearly to indicate the corresponding activity in the Works Programme.

8. THREE MONTH ROLLING PROGRAMME REVISIONS AND UPDATES

- (1) The Three Month Rolling Programme shall be extended forward each month as described above. Each submission of the Three Month Rolling Programme shall be accompanied by

- a Programme Analysis Report, describing actual progress to date, and the forecast for activities occurring over the next three month period.
- (2) If the Three Month Rolling Programme is at variance with the Works Programme, the Programme Analysis Report shall be accompanied by a supporting Narrative Statement describing the Contractor's plan for the execution of the activities to be undertaken over the three month period, including programme assumptions and methods to be employed in achieving timely completion.
 - (3) The Contractor shall revise the Three Month Rolling Programme or propose revisions of the Works Programme, or both, from time to time as may be appropriate to ensure consistency between the two Programmes.

9. DEFINITION OF PROJECT CALENDAR

The definition of the Project calendar is provided in the Conditions of Contract.

10. PROGRAMME AND REPORT SUBMISSION FORMAT

- (1) The Contractor shall submit two sets in English and two sets in Azeri, each consisting of one (1) original, one (1) soft copy, and four (4) copies of all programme submissions to the Engineer.
- (2) The Contractor shall prepare another set in Azeri for submitting to the Employer via the Engineer after Engineer notes.
- (3) All submissions shall be in A0, A1, A2, A3 or A4 size, as appropriate except as may otherwise be agreed by the Engineer. In addition, the computerised programme and report shall be submitted in CD R.
- (4) The format for all Programme and Report submissions shall be in accordance with the format as stated herein or as accepted by the Engineer.

Figure E 1: ACTIVITY 10 CODE STRUCTURE
 (Recommended for use on Project Programme Schedule)

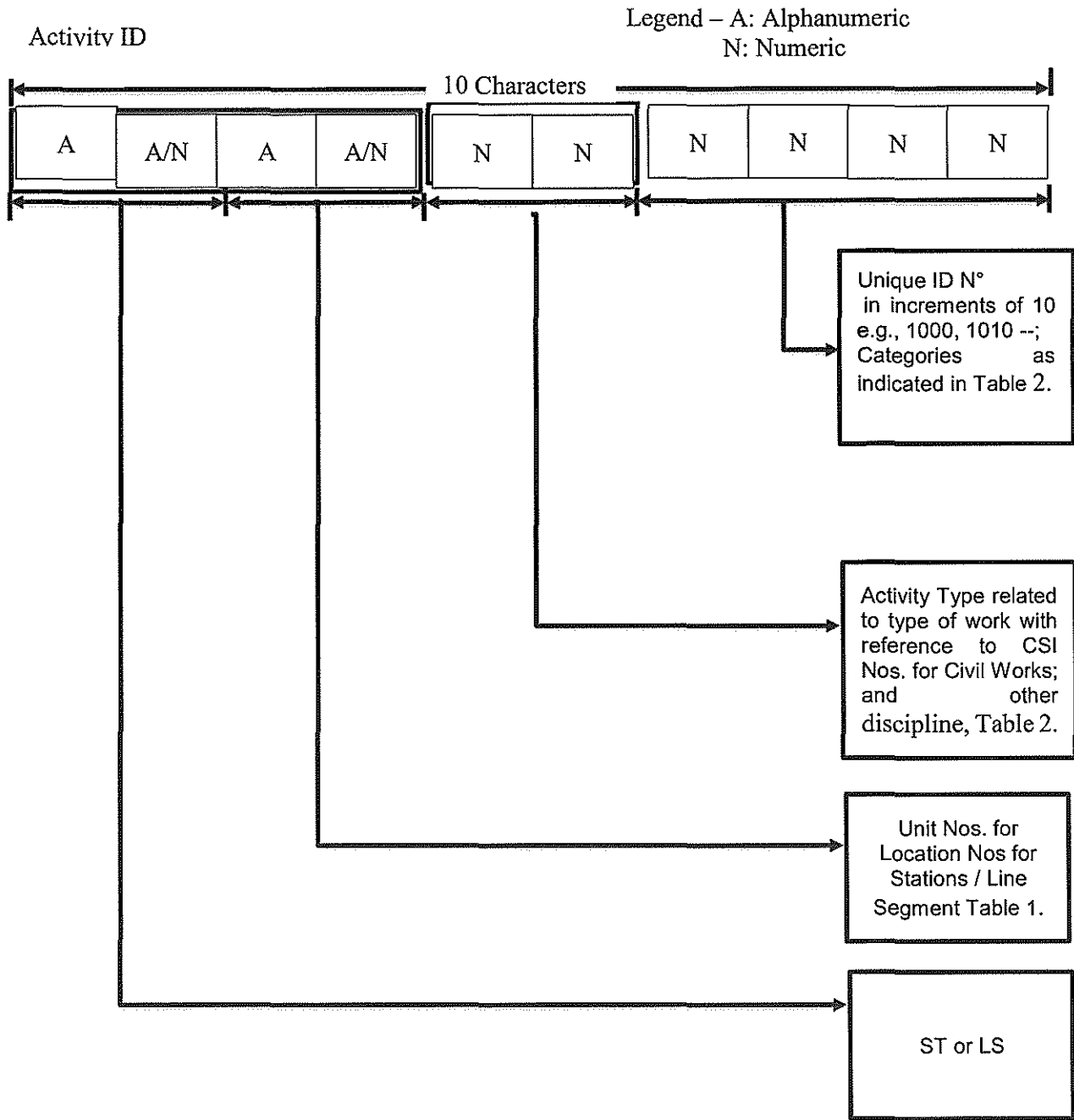

N.B. Milestones ID No's to end with odd No's like 0005, 1005 etc. Activities No's to end in even Nos. like 1010, 3220, etc.

Table 1A. Stations Location Codes

N°	Station Name/location	Code	
0	BAKU	BKU	
10	SUMQAYIT	SUMQ	ST10
11	H.Z. TAGIYEV	TAG	ST11
12	YASMA	YAS	ST12
13	SITAL CHAY	SIT	ST13
14	GILAZI	GIL	ST14
15	ZARAT	ZAR	ST15
16	SIYAZAN	SIY	ST16
17	QIZIL BURUN	QIZ	ST17
18	GIL-GIL-CHAY	GIL	ST18
19	SHABRAN	SHA	ST19
20	SARVAN	SAR	ST20
21	CHARXI	CHA	ST21
22	KHACHMAZ	KHA	ST22
23	GUSAR CHAY	GUS	ST23
24	KHUDAT	KHUD	ST24
25	LAJAT	LAJ	ST25
26	YALAMA	YAL	ST26
27	Crossing Point with Russian Border	RCBP	ST27

Table 1B. Line Segment Codes

N°	From Station/Location		To Station/Location		Unit Numbers
10	SUMQAYIT	SUMQ	H.Z. TAGIYEV	TAG	LS10
11	H.Z. TAGIYEV	TAG	YASMA	YAS	LS11
12	YASMA	YAS	SITAL CHAY	SIT	LS12
13	SITAL CHAY	SIT	GILAZI	GIL	LS13
14	GILAZI	GIL	ZARAT	ZAR	LS14
15	ZARAT	ZAR	SIYAZAN	SIY	LS15
16	SIYAZAN	SIY	QIZIL BURUN	QIZ	LS16
17	QIZIL BURUN	QIZ	GIL-GIL-CHAY	GIL	LS17
18	GIL-GIL-CHAY	GIL	SHABRAN	SHA	LS18
19	SHABRAN	SHA	SARVAN	SAR	LS19
20	SARVAN	SAR	CHARXI	CHA	LS20
21	CHARXI	CHA	KHACHMAZ	KHA	LS21
22	KHACHMAZ	KHA	GUSAR CHAY	GUS	LS22
23	GUSAR CHAY	GUS	KHUDAT	KHUD	LS23
24	KHUDAT	KHUD	LAJAT	LAJ	LS24
25	LAJAT	LAJ	YALAMA	YAL	LS25
26	YALAMA	YAL	Crossing Point with Russian Border	RCBP	LS26

Table 2A. Activity Type list (Suggested Only – Not Mandatory)

Contract N°	Location	Activity Type	Description
		01	General
		02	Site & Civil Construction
		03	Concrete
		04	Masonry/Stone
		05	Metals
		06	Wood Work
		07	Specialities
		08	Equipment & Manufacturing Structures
		09	Electrical/Mechanical
		10	Track Works
		11	Switches/Turnouts
		12	Maintenance Management System
		13	Safety Related
		14	Testing
		15	Commissioning

Table 2B. Unique ID Nos. List (Suggestion Only – Not Mandatory)

Contract N°	Location	Unique ID No.	Description
		0000	Employers/Engineer Related
		1000	Employer's Requirements including Temp. Facilities, Mobilisation Demolitions, Administrative Execution requirements, Traffic Management System
		2000	Design (Civil/Manufacturing Contract)
		3000 to 4000	Construction/Rehabilitation Bridge
		5000	Track
		6000	Testing/Commissioning

APPENDIX 5

MONTHLY PROGRESS REPORT

1. GENERAL

- (1) The Contractor shall submit to the Engineer, a Monthly Progress Report in accordance with the Conditions of Contract Sub-Clause 4.21, and shall be provided in both hard (6 copies) and one soft copy.
- (2) This Report shall be submitted no later than the fifth (5th) day of each calendar month and shall account for all work performed from 26th day of the previous to last month and up to and including the twenty-fifth (25th) day of the month of the previous month.
- (3) The MPR shall be submitted no later than the fifth (5th) day of each calendar month and it shall account for all works actually performed from the first day to the last day of the previous month.
- (4) The Monthly Progress Report (MPR) shall be in both English and Azeri describing the progress and current status of the Works, with progress measured (in days for any delays and percentage for actual progress) against the Contractor's approved Works Programme, which will be used as a baseline.
- (5) The MPR shall be divided into four (4) sections,
 - i. The first covering financial status, and current status relating to design, RAMS;
 - ii. The second covering manufacturing, procurement and material testing and deliveries;
 - iii. The third covers the physical progress, interface issues, programme update (including the 3-month rolling programme) showing the current status of construction and installation progress, and
 - iv. The fourth section covers safety, production, testing, commissioning, environmental and training etc.

2. FINANCIAL STATUS

- (1) A narrative review of all significant financial matters, and actions proposed or taken in respect to any outstanding matters.
- (2) A spread sheet summarising each Cost Centre, the budget, costs incurred during the period, costs to date, costs to go, cost forecast (total of Costs to date and costs to go) and cost variance (difference between cost forecast and budget).
- (3) A spread sheet indicating the status of all payments due and made.
- (4) A report of the status of any outstanding claims.
- (5) The report shall provide interim updated accounts of continuing claims.

3. PROCUREMENT REPORT

- (1) A summary of all significant procurement activities during the month, including action taken to overcome problems.
- (2) A report listing major items of plant and materials which will be incorporated into the Works.
- (3) The items shall be segregated by type as listed in the Specifications and the report should show as a minimum the following activities:
 - a) Purchase Order Date - Scheduled/Actual;
 - b) Manufacturer/Supplier and Origin;
 - c) Letter of Credit Issued date;
 - d) Manufacturer/Supplier Ship Date - Scheduled/Actual;
 - e) Method of Shipment;
 - f) Arrival Date in Azerbaijan - Scheduled/Actual.

4. PHYSICAL PROGRESS

- (1) It shall describe the status of work performed, significant accomplishments, including critical items and problem areas, corrective actions taken or planned and other pertinent activities, and shall, in particular, address interface issues, problems and resolutions.

- (2) It shall include a simplified representation of progress measured in percentage terms compared with percentage planned as derived from the Works Programme.
- (3) Details shall be set out separately in the MPR for the various types of work being planned and works being undertaken, viz:
 - a. Track works
 - b. Drainage
 - c. Bridge works
 - d. Culvert works
 - e. Pedestrian Overpasses
 - f. Track Crossings
 - g. Contamination Remedial Works

5. PROGRAMME UPDATE

- (1) Programme updating shall include:
 - a) The monthly Programme Update which shall be prepared by recording actual activity completion dates and percentage of activities completed up to the twenty-fifth (25th) of the month together with estimates of remaining duration and expected activity completion based on current progress.
 - b) The Programme Update shall be accompanied by an Activity Report and a Narrative Statement.
 - c) The Narrative Statement shall explain the basis of the Contractor's submittal:
 - (i) Early Work and Baseline Submittals - explains determination of activity duration and describes the Contractor's approach for meeting required Key Dates as specified in the Contract.
 - (ii) Updated Detail Programme Submittals - state in the narrative the Works completed and reflected along Critical Path in terms of days ahead or behind allowable dates, specific requirements of narrative are:
 - If the Updated Detailed Work Programme indicates an actual or potential delay to Contract Completion date or Key Dates, identify causes of delays and provide explanation of Work affected and proposed corrective action to meet Key Dates or mitigate potential delays.
 - Identification of any deviation from previous month's critical path.
 - Identify by activity number and description, activities in progress and activities scheduled to be completed.
 - d) Programme Status which shall:
 - (i) Show Works Programme status up to and including the current report period, display Cumulative progress to date and a forecast of remaining work.
 - (ii) Be presented as a bar chart size A3 or A4 and as a time-related logic network diagram on an A1 media, including activity listings.
 - e) The Activity Variance Analysis which shall analyse activities planned to start prior to or during the report period but not started at the end of the report period as well as activities started and/or completed in advance of the Works Programme.

6. THREE-MONTH ROLLING PROGRAMME

The Three-Month Rolling Programme shall be issued monthly.

7. PLANNING AND CO-ORDINATION

- (1) A summary of all planning/co-ordination activities during the month and details of outstanding actions.
- (2) A schedule of all submissions and consents/approvals obtained/outstanding.

8. PRODUCTION AND TESTING

- (1) A review of all production and manufacturing activities during the month.
- (2) Summaries of all production and manufacturing outputs during the month together with forecasts for the next month.
- (3) Review of all testing activities (both at site and at the manufacture's premises) during the month

9. TRACK POSSESSIONS

Critique, lessons learned and details of Track Possessions undertaken, and details of Track Possessions planned and those upcoming and how these will be managed.

10. SAFETY

A review of all safety aspects and safety incidents during the month including reports on all incidents and accidents with details of actions implemented and proposed to prevent further occurrence.

11. ENVIRONMENTAL

A review of all the environmental issues during the past month including all monitoring reports, mitigation measures undertaken and activities to control environmental impacts.

12. PHOTOGRAPHS

Submission requirements for photographs are defined in Part 5. Construction Site Requirements, Clause 14.2.

13 MONTHLY PROGRESS MEETING

A Monthly Progress Meeting (MPM) to monitor the progress of the project shall be convened by the Engineer and attended by the Contractor's Representative, and the Employer. Representatives of all interfacing parties shall be invited and may also be present at the meeting.

APPENDIX 6

QUALITY ASSURANCE

1. GENERAL

- (1) The Contractor shall implement a Project Quality Management Plan in accordance with EN ISO-9001-2015, international (ISO 9001-2015), "Quality System" - Model for Quality Assurance in Production, Installation and Servicing" to ensure that all materials, workmanship, plant and equipment supplied, and work done under the contract meets the requirements of the contract.
- (2) This plan shall apply to all activities related to the quality of items, including designing, purchasing, inspecting, handling, assembling, testing, storing, and shipping of materials and equipment and different elements of construction work and installations of system components.
- (3) The Quality Plan to be prepared by the Contractor and submitted to the Engineer shall follow the requirements of EN ISO 9001-2015 and address each element therein.
- (4) Registration of the Contractor's organisation, or sub-contractors or sub-consultants is not required for this Project, but the Project Quality Management Plan as submitted shall meet the intent of the EN ISO 9001-2015 requirement in that there is a comprehensive and documented approach to achieving the project quality requirements.

2. QUALITY ASSURANCE MANAGEMENT PLAN

- (1) The Project Quality Management Plan (PQMP) shall as a minimum address the quality system elements as required by EN ISO 9001-2015, generally noting the applicability to the Contractor's Works Programme for the Project.
- (2) Procedures or Quality Plans to be prepared by others (Suppliers, Sub-Contractors, etc.) and their incorporation in the overall PQMP shall be identified.
- (3) The Contractor shall provide and maintain a Quality Assurance Plan (QA) to regulate methods, procedures, and processes to ensure compliance with the Contract requirements.
- (4) The QA Plan, including QA written procedures, shall be submitted to the Engineer for his review.
- (5) Adequate records shall be maintained in a readily retrievable manner to provide documented evidence of quality monitoring and accountability.
- (6) These records shall be available to Employer at all times during the term of the Contract and during the Defects Liability Period and for a five-year period thereafter.
- (7) The Plan shall identify:
 - a) Special Product Realization Processes that are product realization activities that Control or verify quality and are performed by certified personnel in accordance with documented procedures that have the written consent of the Engineer;
 - b) Measuring and monitoring procedures shall provide for control and reporting of non-conformances or questionable conditions to the Engineer; Inspection shall occur at appropriate points in the installation sequence to ensure compliance with drawings, test specifications, process specifications, and quality standards while the Engineer may designate, if necessary, inspection hold points into installation or inspection planning procedures;
 - c) Inspection on Delivery procedures to preclude the use of non-conforming materials and to ensure that only correct and accepted items are used and installed;
 - d) Identification, Tracking and Inspection Status system to identify and track the progressive inspection status of equipment, materials, components, sub-assemblies and assemblies as to their acceptance, rejection, or non-inspection shall be maintained;
 - e) Identification and Control of Items: an item identification and traceability control shall be provided;
 - f) Handling, Storage, Preservation and Delivery: provide for adequate work, surveillance and inspection instructions.
- (8) The Plan shall ensure that conditions adverse to quality such as failures, malfunctions, deficiencies, deviations, and defects in materials and equipment shall be promptly identified and corrected.

- (9) The Plan shall provide for establishing and maintaining an effective and positive system for controlling non-conforming material including procedures for the identification, segregation, and disposal of all non-conforming material while the use or repair of non-conforming materials shall require the Engineer's consent.

3 PLAN IMPLEMENTATION AND VERIFICATION

- (1) The Plan shall clearly define the QA Organisation. Management responsibility for the QA shall be set forth on the Contractor's policy and organisation chart.
- (2) The Plan shall define the requirements for QA personnel, their skills and training.
- (3) Records of personnel certifications shall be maintained and monitored by the QA personnel. These records shall be made available to the Engineer for review, upon request.
- (4) The QA operations shall be subject to the Engineer's or his authorised representative's verification at any time.
- (5) Verification will include: surveillance of the operations to determine that practices, methods and procedures of the plan are being properly applied; inspection to measure quality of items to be offered for acceptance; and audits to ensure compliance with the Contract documents.
- (6) The Contractor's Quality Audit Schedule shall be submitted to the Engineer for consent every three months or more frequently as required.
- (7) The results of Quality Audits shall be summarised in the Contractor's monthly reports.
- (8) The Contractor shall provide all necessary access, assistance and facilities to enable the Engineer to carry out on-site and off-site surveillance of Quality Assurance Audits to verify that the quality system which has the consent of the Engineer is being implemented fully and properly.

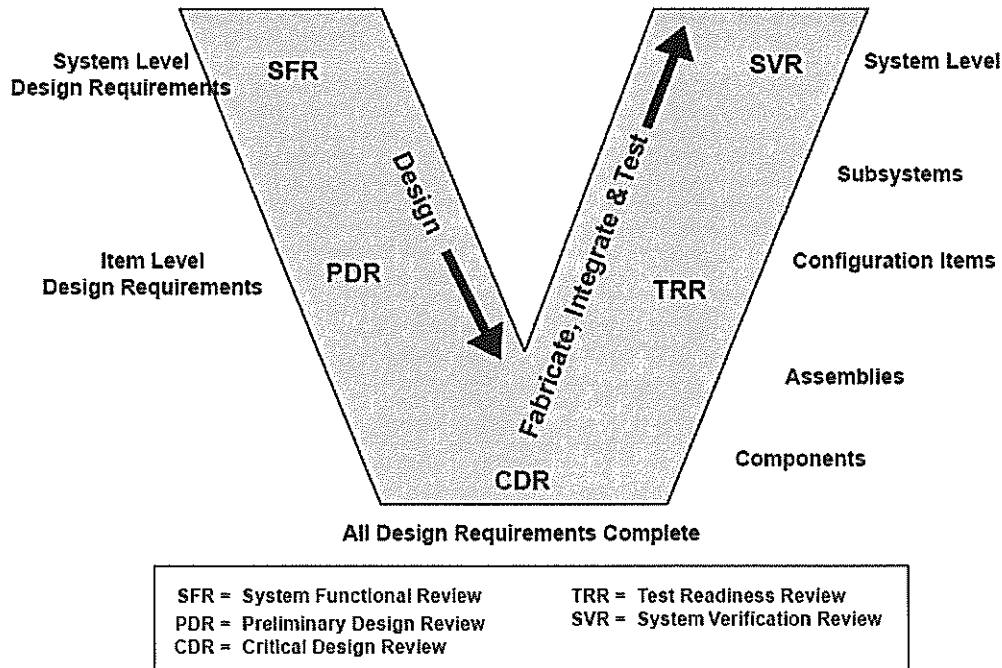

APPENDIX 7

DRAWINGS AND CAD STANDARD

1. INTRODUCTION

- (1.1) The purpose of this document is to define the minimum Drawing and CAD standard to be achieved by the Contractor for all drawings produced by the Contractor for the Works.
- (1.2) By defining a common format for the presentations of drawings and CAD files, the exchange of drawn information is improved and will maximise the use of CAD in the co-ordination process.
- (1.3) All submissions shall be made to the Engineer's requirement in a format reviewed without objection by the Engineer in accordance with the requirements in:
- the Contract;
 - the Document Submittal Instructions to Consultants and Contractors.
- (1.4) Paper and drawing sizes shall be "A" series sheets as specified in ISO 5457.
- (1.5) The following software compatible for use with Intel-Windows based computers shall be used, unless otherwise stated, for the various electronic submissions required:

2. DOCUMENT TYPE

Document Type:	Electronic Document Format
AutoCAD Graphics:	AutoCAD 2017 or latest versions
Photographic:	Adobe Photoshop CS2 or latest version
Desktop publishing:	Page Maker 7.0 or latest version
CAD Drawings:	AutoCAD 2016 or latest version

(2.1) Media for electronic file submission:

One copy shall be submitted unless otherwise stated on CD-ROM media. The media shall be CD-R and the recording method shall not allow any further changes to the recordable disk.

(2.2) Internet File Formats/Standards:

- The following guidelines shall be followed when the Contractor uses an Internet browser as the communication media to share information with the Employer.
- All the data formats or standards must be supported by Microsoft Internet Explorer version 10 or above running on Windows 8 or latest version.
- The following lists the file types and the corresponding data formats to be used on Internet. The Contractor shall comply with them unless prior consent is obtained from the Engineer for a different Data format:

<i>File Type</i>	<i>Data/Format</i>
Photo Image	Joint Photographic Experts Group (JPEG)
Image other than Photo	GIF or JPEG
Computer Aid Design files (CAD)	Computer Graphics Metafile (CGM) and DWG
Video	Window video (.avi)
Sound	Wave file (.wav)

The following states the standards to be used on the Internet when connecting to database(s). The Contractor shall comply with them unless prior consent is obtained from the Engineer for a different standard:

<i>Function to be implemented</i>	<i>Standard to be complied with</i>
Database connectivity	Open Database Connectivity (ODBC)
Publishing hypertext language on the World Wide Web	Hypertext Mark-up Language (HTML)

3. GENERAL REQUIREMENTS

r) GENERAL

(1) The Contractor shall adopt a title block similar to that used in the Drawings for all the Contractor's Documents prepared under the Contract.

(2) Each document shall be uniquely referenced by a document number and shall define both the status and revision of the drawing.

(3) The current status of each document shall be clearly defined by the use of a single letter code as follows:

(a) A single letter character denoting the Status of the Drawings e.g.

T	Tender Design
W	Working Drawing (By Contractor)
M	Manufacturing Drawing
S	Site Drawing
D	Shop Drawing
A	As-Built Drawing

(b) A single digit code denoting the contract number (for the whole line)

1	Design
2	Civil/Track Works from Sumqayit to Russian Border

(c) A two (2) letter code denoting the type of civil works or system elements e.g.

CG	General Works
ST	Stations
AL	Alignment
RW	Right - Of - Way
CE	Civil Engineering (earth work, culverts, pedestrians, footbridge, survey, track drainage, etc.)
RB	Railway Bridges
EC	Environmental Control System
UT	Utilities (Power, Gas, Telecoms, Water Sewers)
SE	Structural Project Management (structural steel, reinforced concrete etc.)
GE	Geotechnical Project Management (Instrumentation, ground treatment, de-watering, etc.)
AR	Architecture
LS	Landscape
EE	Electrical Project Management (low voltage)
ME	Mechanical Project Management (ventilation, firefighting, plumbing)
PS	Power Supply (high-voltage, traction power)
SG	Signalling (train control)
CM	Communications
TK	Track work
TM	Traffic Management (Roads, Pavements)
WS	Water Supply

(d) A unique four (4) digit number (from 0001 to 9999), identifying each drawing.

(e) A single letter (A to Z except I and O) denoting the sequence of revision to the drawing. The initial drawing issue will carry a revision letter "A".

s) TYPES of DRAWINGS

(3.1) Working drawings are Contractor's Documents in sufficient detail to fully describe the Works and adequate for construction or installation.

- (3.2) Site drawings and sketches are Drawings, often in sketch form, prepared on-site to describe modifications of the Working Drawings where site conditions warrant changes that do not invalidate the design.
- (3.3) Shop drawings are special drawings prepared by the manufacturer or fabricator of various items within the Works to facilitate manufacture or fabrication.
- (3.4) Reference drawings are Contractor's Documents in sufficient detail to fully describe the Works and adequate for construction or installation and revised and approved by the Authorities. Reference Drawings shall be obligatory drawings for the construction works.
- (3.5) As-built drawings show the Works exactly as constructed or installed. They are usually prepared by amending the working drawings to take into account changes necessitated by site conditions and described in Site drawings. These drawings shall be completed on a regular basis as the works progress and shall not be left until completion of the entire works.

7 COMPUTER AIDED DESIGN AND DRAWING (CAD) STANDARDS

a) INTRODUCTION

The production of all CAD data files shall comply with the applicable legislation in Azerbaijan, standards for the relevant issue and the requirements as defined hereinafter.

8 OBJECTIVES

- (5.1) The main objectives of the CAD standards are as follows:
 - (a) To ensure that the CAD data files produced for Project are co-ordinated and referenced in a consistent manner.
 - (b) To provide the information and procedures necessary for a CAD user from one discipline or external organisation to access (and use as background reference), information from a CAD data file prepared by another discipline or external organisation.
 - (c) To standardise the information contained within CAD data files which may be common to more than one discipline such as drawing borders, title boxes, grid lines etc.
 - (d) To establish procedures necessary for the management of CAD data files.
 - (e) To ensure all Contractors use 'Model space' and 'Paper space' in the production of their CAD files.

9 GENERAL

- (6.1) To facilitate co-ordination between Contractors, it is a requirement that all drawings issued by Contractors for co-ordination or record purposes shall be produced using CAD methods.
- (6.2) The intent of the issue of digital information is to aid the interface design by others.
- (6.3) The definitive version of all drawings shall always be the paper or polyester film copies which have been issued by the Contractor or organisation originating the drawing.
- (6.4) Drawings and drawing packages issued for co-ordination, record purposes or for acceptance shall be accompanied by a complete set of the corresponding CAD data files.
- (6.5) Any Contractor or organisation making use of the CAD data from others shall be responsible for satisfying him that such data is producing an accurate representation of the information on the corresponding paper drawing which is satisfactory for the purpose for which he is using it, provided the general principles of this portion have been achieved by the originator of the CAD data, Contractors making use of the CAD data from others shall not be entitled to require alterations in the manner in which such CAD data is being presented to them.
- (6.6) In particular, automatic determination of physical dimensions from the data file shall always be verified against the figured dimensions on the paper or polyester drawings.
- (6.7) Figured dimensions shall always be taken as correct where discrepancy occur.

10 TERMINOLOGY and ASSOCIATED STANDARDS

Any terminology used within this section that is ambiguous to the user shall be clarified with the Engineer. Azerbaijan Standards is used in principle as a guide for drawing practice, convention, CAD data structure and translation.

11 PAPER DRAWINGS

- (8.1) For the Project "Paper" drawings are considered to be the main vehicle for the receipt and transmittal of design and production information, typically plans, elevations and sections.
- (8.2) The Project wide accepted media for the receipt and transmittal of "Paper" drawings will be paper and polyester film of various standards ISO 'A' sizes with the composition of this information derived from a CAD "Model". (3) The CAD derived "Paper" drawing composition will reflect a window of information contained within a CAD "Model Space" file together with a selection of information contained within the associated CAD "Paper Space" file.

12 CAD DATA CREATION, CONTENT and PRESENTATION

(9.1) A consistent method of CAD data creation, together with content and presentation is essential. The method of CAD "Model Space and Paper Space" creation is as follows:

(a) Model Space Files

- (i) Typically, CAD "Model Space" files are required for general arrangement and location plans and will consist of a series of other "Model Space" referenced CAD files covering the total design extents at a defined building level (the number of referenced files should be kept to an absolute minimum).
- (ii) Data contained within a CAD "Model Space" files is drawn at full size (1:1) and located at the correct global position and orientation on the Project Grid / or defined reference points.
- (iii) Each CAD "Model Space" file will relate to an individual discipline.
- (iv) Drawing border / text, match / section lines or detailed notation shall NOT be included within a CAD "Model Space" file.
- (v) Dimensions shall be included within a CAD "Model Space" but located on a dedicated layer.
- (vi) Elevations, Long Sections and Cross Sections shall also be presented in CAD "Model Space" as defined above, but do not need to be positioned and orientated on the Project Grid.

(b) Paper Space CAD Files

- (i) Paper Space" CAD files are utilised to aid the process of plotting "Paper" drawings and are primarily a window of the CAD "Model Space" file.
- (ii) A "Paper Space" CAD file will typically contain drawing borders, text, match or section lines & detailed notation.
- (iii) The purpose is to ensure that total co-ordination is achieved between the CAD "Model Space" file and the "Paper Drawing" output during the revision cycle of the design and production process.
- (iv) Duplicated data in "Model and Paper Space" files will not be acceptable unless an automatic update link exists between the two data sets.
- (v) "Paper Space" files are not typically required as part of the CAD Media Receipt from Contractors, unless specifically requested.

13 CAD QUALITY CONTROL

(10.1) Random CAD Quality Control Audits will be carried out by Engineer on all CAD media received and transmitted.

- (10.2) These checks DO NOT verify the technical content of the CAD data received or transmitted (as this is the responsibility of the originating organisation); however, compliance with Project CAD and Drawing Standards shall be checked.
- (10.3) In addition, all Contractors who transmit and receive CAD data from the Project shall have CAD quality control procedures in place.
- (10.4) A typical quality control procedure shall contain CAD data quality checking routines coupled with standards for CAD data transmittal and archiving.

14 CAD DATA TRANSFER MEDIA and FORMAT

- (11.1) When CAD data is received & transmittal between Engineer and the Contractor, the media shall be as follows:
 - (a) Data Exchange Format - AutoCAD Release 2016 or latest version (*.DWG)
 - (b) Operating System - Windows 8 or latest version
 - (c) Data Transfer Media - CD-R/RW, DVD+/-R, USB Flash Memory Card
- (11.2) All CD-R1RW and DVD+/-R must be labelled on the data shield with:
 - (i) Name of Company
 - (i). Project Title
 - (iii) Drawing Filenames
 - (iv) Disk No. / Total No. of disks
- (11.3) All media shall be submitted with a completed Form (CAD Disk)
- (11.4) The Contractor must ensure the supplied media is free from any viruses.

15 CAD MEDIA RECEIPT and TRANSMITTAL

- (12.1) CAD Media Transmittal (from the Contractor to Engineer) - this will consist of the following:
 - (a) CAD Digital Media (CD-R1RW or DVD+/-R or USB Flash Memory Cards shall typically contain CAD "Model Space" and "Paper Space" files.
 - (b) CAD data sheet
 - (c) CAD issue / revision sheet
 - (d) CAD Quality Checklist confirming compliance
 - (e) Plot of each "Model Space" file issued on an A1 drawing sheet (to best fit).
- (12.2) The above CAD media will be collectively known as "CAD Media Transmittal Set". The CAD data file transmittal format required by Employer's Representative from all Contractors shall be in AutoCAD (version 2016) or latest version.
- (12.3) All CAD media received from Contractors will be retained by the Engineer except for USB Flash Memory Cards (if used) as an audit trail/archive of a specific Contractor's design evolution.
- (12.4) CAD Media Receipt (from Engineer to the Contractor):
 - (a) CAD media should normally be obtained from the Engineer who will issue CAD media for preparation of the working drawings and will consist of the following:
 - (i) CAD Digital Media (CD or DVD disks typically containing only CAD Space" files
 - (ii) CAD data sheet "Model"
 - (iii) CAD issue / revision sheet
 - (b) The above CAD media will be collectively known as the "CAD Media Receipt Set". The CAD data file transmittal format used by Engineer's Representative to all Contractors will be in AutoCAD (version 2016 or latest version.)
 - (c) Each CAD transmittal disk shall be labelled with proper disk label as approved by the Engineer's Representative. Any CAD data transmitted without this label is assumed to be provisional information not to have been quality checked and therefore not formally issued.

16 REVISIONS

- (1) All 'Revisions', 'In Abeyance' and 'Deletions' shall be located on a common layer which can be turned on or off for plotting purposes.
- (2) The following example text indicates the current CAD file revision, i.e. 'Revision [AJ]', allocated to a defined layer on all CAD "Model Space" files, in text of a size that will be readable when the CAD "Model Space" file is fitted to the screen, with all levels on.

17 BLOCK LIBRARIES, BLOCKS and NAMES

- (1) All Construction Industry symbols produced as CAD Cells shall typically conform to Azerbaijan Standards.
- (2) All Blocks created shall be Primitive (i.e. NOT Complex) and shall be placed Absolute (i.e. NOT Relative).
- (3) The Contractor's specific block libraries shall be transmitted to Engineer's Representative together with an associated block library list containing the filename (max. 6 characters) and block description.
- (4) The Contractor shall ensure that the library is regularly updated and circulated to all other users, together with the associated library listing.
- (5) All Blocks of a common type, symbols or details should initially be created within a CAD "Model Space File" specifically utilised for that purpose. These files will be made available on request by Engineer's Representative.
- (6) All Blocks created will typically be 2D unless 3D is specifically requested. In both instances, they shall have an origin at a logical point located within the extents of each Block's masked area or volume.

18 CAD DIMENSIONING

- (1) Automatic CAD Dimensioning will be used always.
- (2) Any dimensional change must involve the necessary revision to the model space file.
- (3) If the CAD Quality Control Checks find that the revisions have not been correctly carried out, the rejection of the entire CAD submission will result.

19 CAD LAYERING

- (1) All CAD elements shall be placed on the layers allocated for each different discipline.
- (2) The Contractor's layer naming convention shall be submitted for Engineer approval.

20 GLOBAL ORIGIN, LOCATION and ORIENTATION on the ALIGNMENT DRAWINGS

- (1) Location or Plan information in "Model Space" files shall coincide with the correct location and orientation on the Project grid for each specific contract.
- (2) Location plans shall have at least three setting out points shown on each CAD "Model Space" file. Each setting out point shall be indicated by a simple cross-hair together with related Eastings and Northings co-ordinates.
- (3) The Civil Contractor(s) will establish the three setting out co-ordinates for their respective works, which will then be used by all other Contractors including the Contractor.

21 LINE THICKNESS and COLOUR

(1) To assist plotting by other users, the following colour codes will be assigned to the following line thickness / pen sizes:

Colour	Code No.	Line Thickness
Red	10	0.18
White	7	0.25
Yellow	2	0.35
Brown	34	0.5
Blue	130	0.7
Orange	30	1.0
Green	3	1.4
Grey	253	2.0

22 CAD UTILISATION of 2D and 3D FILES

Although the project standard is 2D CAD files, certain disciplines and Contractors may use 3D CAD files for specific applications or where the isolated use of 3D aids the design and visualisation process (i.e. Architecture, Survey and Utilities).

23 CAD FILE NUMBERING

- (1) Contractor's CAD File Numbering shall be as described in 2 above.
- (2) The Employer will not be required to produce numerous CAD files but, where required, will follow the numbering system set out above except that the status of the drawing in 2.1
- (3) Shall be "E".

24 CAD FILE NAMING CONVENTION

CAD "Model Space" files shall be named in accordance with general drawing conventions.

APPENDIX 8

SITE AND TEMPORARY POWER SUPPLY

1. INTRODUCTION

(1) The standard conditions applying to the use of any Works Area by the Contractor for its site facilities are given under Clause 2 of this Appendix.

2. STANDARD CONDITIONS

The following standard conditions apply to those areas of the Site that are applicable:

a) Forming of Areas

- (i) The Site shall be formed to the levels shown on the Drawings.
- (ii) No levels shall be amended without prior consent of the Engineer.
- (iii) The Site shall be surfaced in a manner agreed with the Engineer, compatible with their intended use, and, in particular, footpaths and roadways connecting facilities shall be provided.
- (iv) Measures shall be taken to the satisfaction of the Engineer to ensure all areas are properly drained and kept free of static water.

b) Roads and Parking

- (i) Space shall be provided within the Site for parking, loading/unloading and manoeuvring of motor vehicles.
- (ii) Any damage caused by the Contractor to the adjoining public roads and fixtures and properties (public or private) shall be made good to the satisfaction of the Engineer and its Owner.

c) Drainage and Sewerage

- (i) All storm or rainwater from the Work Areas including any access roads thereto shall be conveyed to the nearest stream course, which has the necessary capacity, catch-pit, and channel or storm water.
- (ii) All temporary and permanent works shall be carried out in such a manner that no damage or nuisance are caused by storm water or rain water to the Site and adjacent property.
- (iii) Damage or obstruction caused to any watercourse, drain; main or other water installations within or adjoining the Site shall be made good to the satisfaction of the Engineer.
- (iv) Treatment and disposal of sewage and wastewater from the Works Area shall be provided to the satisfaction of the Engineer following the ecological requirements.

d) Buildings

- (i) No permanent structures other than those required for the Permanent Works shall be permitted on the Site.
- (ii) The Contractor, as required, for all temporary buildings shall provide electricity, water, telephone and sewerage.

e) Pedestrian Access

(i) Any accesses or passing through the Site by not shall be maintained in usable condition at all times to the satisfaction of the Engineer including lighting, signing and guarding.

3. WORK ON SITE

(1) The Contractor shall nominate a qualified electrical engineer, whose name and qualifications shall be submitted in writing to the Engineer for review, who shall be solely responsible for ensuring the safety of all temporary electrical equipment on Site.

(2) The Contractor shall not install or operate any temporary electrical systems on the Site until this electrical engineer is appointed and has commenced duty.

(3) The name and contact telephone number of the qualified electrical engineer shall be displayed at the main distribution board for the temporary electrical supply so that he can be contacted in case of an emergency.

(4) The Contractor shall submit all base electrical circuits, characteristics and the details of the equipment for all temporary electrical installations, together with details of the temporary electrical equipment shall be submitted to the Engineer for his consent.

(5) All electrical installation work on Site shall be carried out in accordance with the requirements laid down in the Specification and Azerbaijan standards or approved international standards.

(6) All work shall be supervised or executed by qualified electrical engineer or suitably skilled and authorised electricians.

4. ELECTRICAL

4.1 GENERAL

(1) All temporary electrical site installations and distribution systems shall be in accordance with:

- a) AZERBAIJAN National Electrical Company Supply Rules;
- b) Wiring Regulations;
- c) Distribution of Electricity on Construction and Building Sites;
- d) Distribution Assemblies for Electricity Supplies for Construction and Building Sites;
- e) Regulation No.2 for fire safety norms and requirements for Civil works; and
- f) Any other applicable Azerbaijan standards and regulations.

5. MATERIALS, APPLIANCES AND COMPONENTS

All materials, appliances and components used within the distribution system shall comply with Azerbaijan standards or approved international standards.

5.1 DESIGN CONSIDERATIONS

(1) Distribution equipment utilised within the temporary electrical distribution system shall incorporate the following features:

- a) flexibility in application for repeated use;
- b) suitability for transport and storage;
- c) robust construction to resist moisture and damage; and
- d) safety in use.

(2) All cabling shall be run at elevated level whenever possible and be firmly secured to ensure it does not present a hazard or obstruction to people and equipment.

5.2 MAINS VOLTAGE

(1) The Site mains voltage shall be as per the AE, 380V/ 3 phases 4-wire system 50 Hz.

- a) Single phase voltage shall be as per the AE, 220V supply.
- b) Reduced voltages shall conform to Azerbaijan standards or approved international standards.

(2) The following voltages shall be adopted for typical applications throughout the distribution systems:

- a) Fixed plant - 380V/ 3 phase;
- b) Movable plant fed by trailing cable - 380V /3 phase;
- c) Installations in Site buildings - 220V /1 phase;
- d) Fixed flood lighting - 220V/ 1 phase;
- e) Portable and hand-held tools - 12, 24 or 36V /1 phase;
- f) Site lighting (other than flood lighting) - 12, 24 or 36V /1 phases; and
- g) Portable hand-lamps (typical use) - 12, 24 or 36V /1 phase.

(3) When the low voltage supply is energised via the Employer's power supply, any power utilised from that source shall be either 380V 3 phase or 220V single phase as appropriate and the Contractor shall carry out any conversion that may be necessary to enable him to use power from that source.

(4) Protection of Circuits

- a) Protection shall be provided for all main and sub-circuits against excess current, under and over voltage, residual current and earth faults.
- b) The protective devices shall be capable of interrupting (without damage to any equipment or the mains or sub-circuits) any short circuit current that may occur.
- c) Discrimination between circuit breakers, circuit breakers and fuses shall be in accordance with the Azerbaijan standards or approved international standards.

5.3 EARTHING

(1) Earthing and bonding shall be provided for all electrical installations and equipment to prevent the possibility of dangerous voltage rises and to ensure that faults are rapidly cleared by installed circuit protection.

(2) Earthing systems shall conform to the following standards:

- a) Wiring Regulations;
- b) Guide for Safety in AC Substation Grounding.

5.4 PLUGS, SOCKET OUTLETS AND COUPLERS

Low voltage plugs, sockets and couplers, as well as the high-voltage couplers and 'T' connections shall be colour coded in accordance, and conform to Azerbaijan standards or approved international standards.

5.5 CABLES

(1) Cables shall be selected after full consideration of the conditions to which they will be exposed and the duties for which they are required.

(2) Supply cables up to 3.3kV shall be in accordance with Azerbaijan standards or approved international standards.

(3) For supplies to mobile or transportable equipment where operation of the equipment subjects the cable to flexing, the cable shall conform to Azerbaijan standards or approved international standards, as well as one of the following specifications appropriate to the duties imposed by it:

- a) flexible cables for use at mines and quarries;
- b) rubber insulated cables for electric power and lighting; and
- c) insulated flexible cords and cables.

(4) Where low voltage cables are to be used, reference shall be made to Azerbaijan standards or approved international standards, the following specifications shall also be referred to particularly for underground cables:

- a) for armoured PVC insulated cables; and
- b) flexible cables for use at mines and quarries.

(5) All cables which have a voltage to earth exceeding 65V (except for supplies from welding transformers to welding electrodes) shall be metal sheathed and/or armoured which shall be continuous and effectively earthed. In the case of flexible or trailing cables, such earthed metal sheath and/or armour shall be in addition to the earth core in the cable and shall not be used as the sole earth conductor.

(6) Armoured cables having an over-sheath of polyvinyl chloride (PVC) or oil resisting and flame-retardant compound shall be used whenever there is a risk of mechanical damage occurring.

(7) For resistance to the effects of sunlight, overall non-metallic covering of cables shall be black in colour.

(8) Cables with an applied voltage to earth exceeding 12V but not normally exceeding 65V shall be insulated and sheathed with a general purpose or heat resisting elastomer.

(9) All cables that are likely to be frequently moved in normal use shall be flexible cables. Flexible cables shall be in accordance with Azerbaijan standards or approved international standards.

5.6 LIGHTING INSTALLATION

(1) Where site works are required during the night, the lighting circuits shall be run separate from other sub-circuits and shall be in accordance with Azerbaijan standards or approved international standards.

(2) Voltage shall not exceed 55V to earth except when the supply is to a fixed point and where the lighting fixture is fixed in position.

(3) Luminaries shall have a degree of protection not less than IP 54.

(4) In particularly onerous environments where the luminaries are exposed to excesses of dust and water, a degree of protection to IP 65 shall be employed.

(5) The Contractor shall provide a minimum lighting level of 200 lux by localised lighting in all areas where required for carrying out the works.

(6) Wherever a risk of damage may occur, luminaries shall be mechanically protected against impact damage by use of wire guards or other such devices.

5.7 ELECTRIC MOTORS

(1) Totally enclosed fan cooled motors to Azerbaijan standards or approved international standards shall be used.

(2) Motor control and protection circuits shall be as stipulated in Azerbaijan standards or approved international standards.

(3) Emergency stop switches shall be provided for all machinery.

5.8 INSPECTION AND TESTING

Electrical installations on Site shall be inspected and tested in accordance with the requirements of the Wiring Regulations.

5.9 IDENTIFICATION

Identification labels shall be affixed to all electrical switches, circuit breakers and motors to specify their purpose.

5.10 MAINTENANCE

(1) Regular maintenance and checking of control apparatus and wiring distribution systems shall be carried out by an electrical engineer or electrician (duly qualified to carry out the said checks) to ensure safe and efficient operation of the systems.

(2) All portable electrical appliances shall be permanently numbered (scarf tag labels or similar) and a record kept of the date of issue, date of the last inspection and the recommended inspection period.

5.11 METERING

The Contractor shall install and register a separately electrometer for each supplies of electricity from Azerbaijan Electricity Company or other Suppliers. The Contractor shall pay the supplied electricity Power.

APPENDIX 9

PROJECT CALENDAR

1. THE PROJECT CALENDAR

For the purposes of defining the Project Calendar the following definition shall apply:

- 1) The Project Weeks shall commence on a Monday.
- 2) A day shall be deemed to commence at 00:01 hour on the morning of the day in question.
- 3) Where reference is made to the completion of an activity or Milestone by a particular week, this shall mean by midnight on the Sunday of that week.
- 4) Requirements for the computation of Key Dates are given in **Appendix 2** to the Technical Requirements.
- 5) A 7-day week calendar shall be adopted for various (Work) programme schedules for scheduling purposes.
- 6) For Project purposes, the presentation shall be in "Week" units.
- 7) A 7-day working week may be required to satisfactorily complete the Works. Application for the extended working hours if required shall be made to the Engineer for approval.

APPENDIX 10

FIRST AID BASE

1. FIRST AID BASE

- 1.1 First aid bases shall be located at each of the Contractor's principal work areas.
- 1.2 The base shall consist of a treatment room fitted with two treatment couches, a hand wash basin, sterilising equipment and lockable cupboards to contain sufficient medical supplies for the Contractor's personnel, the Employer / Engineer's personnel, the Interfacing Contractors working in the area and any visitors to the Site.
- 1.3 In addition, two stretchers shall be stored, available for instant use.
- 1.4 The first aid base shall contain a recovery room that shall be furnished with six chairs and six footrests.
- 1.5 The first aid base shall be air-conditioned, with cooling and heating capability sufficient to maintain the temperature of the inside of the building at 20°C.

2. STAFFING

- 2.1 A qualified doctor shall be available on-call during all times when work is being undertaken on-site.
- 2.2 A nurse shall be in attendance at the first aid bases during all times when work is being undertaken on the Site.
- 2.3 In each site office and location at least one employee of the Contractor shall be trained in first aid and shall be available during all working hours for the purpose of attending to emergencies.
- 2.4 The Contractor may conclude a contract with the local health centres where they are unable to implement any of the above services

3. EQUIPMENT

- 2.1 A fully equipped ambulance and driver shall be available on call during all working hours.
- 2.2 The ambulance shall be equipped with emergency life support equipment suitable for application in construction site accidents.
- 2.3 Portable first aid boxes (including equipment and medications for snake bite) shall be maintained fully equipped at each of local site offices and work locations where twenty (20) or more persons work at a time.

APPENDIX 11

**LEVEL CROSSINGS
PEDESTRIAN CROSSINGS
ANIMAL CROSSINGS
FENCES**

LEVEL CROSSINGS

Details of the level crossings are set out in the table below. Refer to **Attachment 1** for further details on level crossings.

Lot 1 - Level Crossing Details

Level Crossing No.	Chainage	Width metres (Min)	Type
23	2539+300	7.0	Concrete
24	2544+700	7.0	Concrete
25	2550+000	8.0	Rubber/Polymer
26	2554+600	7.0	Concrete
27	2569+700	7.0	Concrete
28	2579+800	8.0	Rubber/Polymer
29	2584+800	7.0	Concrete
30	2592+000	8.0	Rubber/Polymer
31	2596+300	7.0	Concrete
32	2602+800	8.0	Rubber/Polymer

ANIMAL CROSSINGS

Details of the level crossings are set out in the table below. Refer to **Attachment 2** for further details on animal crossings.

Lot 1 - Animal Crossing Details

Animal Crossing No.	Chainage	Width in metres (Min)	Type
3	2540+000	2.0	Non-slip concrete or rubber/polymer
4	2548+400	2.0	
5	2555+800	2.0	
6	2560+500	2.0	
7	2565+000	2.0	
8	2578+100	2.0	
9	2580+400	2.0	
10	2590+400	2.0	
11	2622+600	2.0	

TYPE 'A' FENCE DETAIL

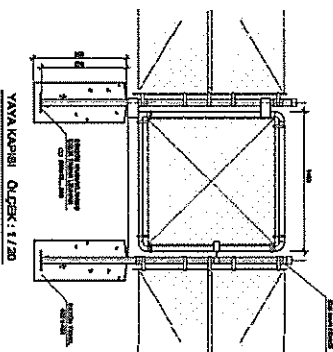
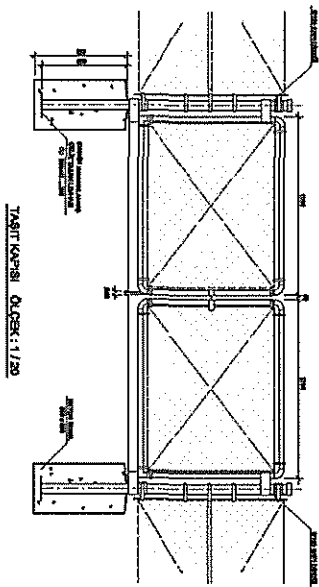
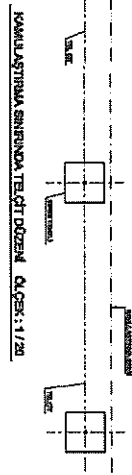
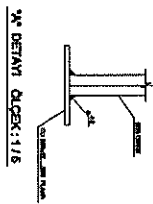
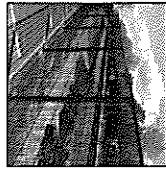
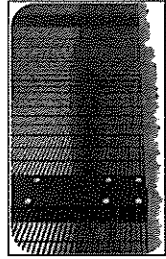
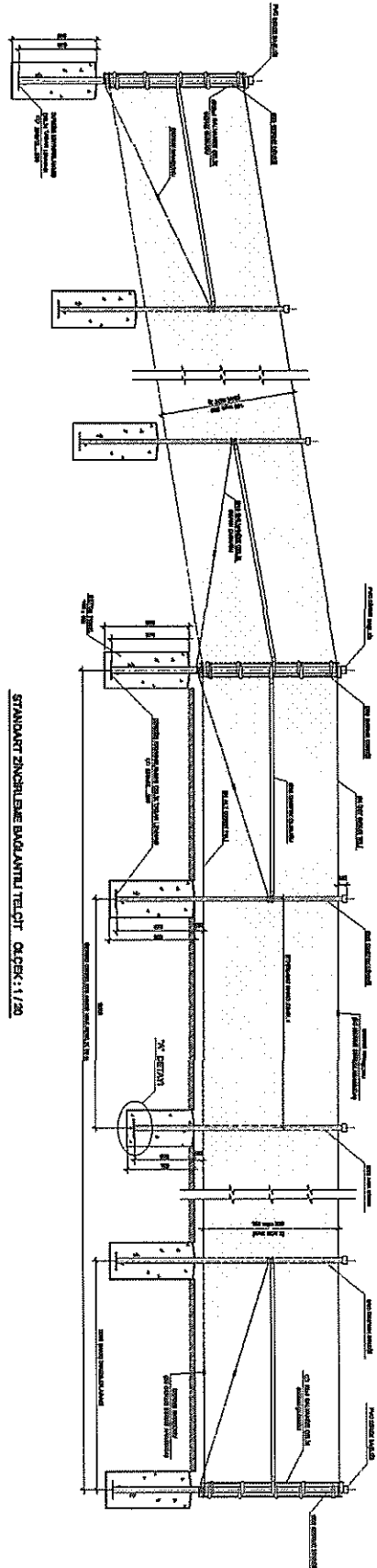

- REVISI**
- 1.1. Detail and bahannya dengan cara ini.
 - 2.1. Detail and bahannya dengan cara ini.
 - 3.1. Detail and bahannya dengan cara ini.
 - 4.1. Detail and bahannya dengan cara ini.
 - 5.1. Detail and bahannya dengan cara ini.

APPENDIX 12

**REQUIREMENT FOR THE SITE SAFETY
PLAN**

1 GENERAL

The Contractor shall, within two (2) months of the Date of Commencement, prepare and submit to the Engineer for review his proposed safety plan which shall contain as a minimum those items set out in this Appendix.

2 STATEMENT of the CONTRACTOR'S SAFETY POLICY

- 2.1 The Contractor shall produce a policy statement signed by the managing director of the Contractor or other senior officer acceptable to the Engineer, or the managing directors or other senior officers acceptable to the Engineer of each company of the consortium, partnership or joint venture comprising the Contractor, declaring that the Contractor shall ensure that safety and industrial health are given priority consideration in all aspects of the Works and by the Contractor in discharging his contractual obligations;
- 2.2 An understanding of and means of ensuring due compliance with the statutory regulations and standards relating to construction work in Azerbaijan;
- 2.3 An understanding of and means of ensuring due compliance with the ADY regulations and standards relating to working in and around an operational railway environment in Azerbaijan;
- 2.4 The statutory and contractual obligations regarding safety, rescue and industrial health imposed on the Contractor; and the means by which the Contractor will supervise, monitor and audit his site safety assurance system to ensure due compliance with these obligations.

3 SENIOR MANAGEMENT RESPONSIBILITY for SAFETY

- 3.1 The name(s) and experience of person(s) within the Contractors proposed management structure who would be responsible for co-ordinating and monitoring the overall safety performance of the Contractor, all Sub-Contractors and Safety Officers.

4 APPOINTMENT, DUTIES and RESPONSIBILITIES of SAFETY STAFF

- 4.1 The safety staff and organisational structure, which should identify the personnel to be engaged solely for site safety assurance, the responsibilities of the participants and the subdivision of the site safety assurance tasks into elements which can be effectively controlled, technically and managerially.
- 4.2 Names, addresses, telephone and facsimile numbers of all participants shall be listed where known (Supplements to the Site Safety Plan will update and complete this information);
- 4.3 The criteria for appointment of principal safety staff;
- 4.4 The powers vested in the safety staff, which shall be sufficient to enable them to take urgent and appropriate action to make safe the Site and prevent unsafe working practices or other infringements of the safety plan or statutory regulations;
- 4.5 The proposed interaction and communication procedures between the Contractor's construction personnel and safety staff, including proposals for radio communication facilities, in particular the establishment of a regular communication and reporting system between the Safety Officer and the director responsible for the Contract and the Safety Officer and the Site Manager shall be demonstrated;

- 4.6 The frequency, coverage and intent of regular site safety reports;
- 4.7 The means by which the site safety assurance system will be supervised, monitored and audited by the Safety Officer to ensure due compliance with the principles and objectives of the Site Safety Plan at all levels of construction.
- 4.8 Procedures for updating the Site Safety Plan and associated assurance system shall be given;
- 4.9 The records to be prepared and maintained by the Safety Officer and safety staff and communication procedures to be adopted by the Safety Officer such that the Engineer, Employer and others associated with the Works (e.g. sub-Contractor) are kept fully informed on matters relating to site safety and industrial health regulations throughout the period of the, Contract.

5 POLICY for IDENTIFYING HAZARDS

- 5.1 How the Contractor will identify hazards, assess the risks and develop procedures and method statements to minimise the risk for those risks which will occur during the works;
- 5.2 The aspects of the Temporary Works design which should be communicated to the Engineer and others directly or indirectly associated with the Works if the installation of the associated works has a significance on the site safety of the Works or a risk to train operations;
- 5.3 The Contractor shall produce a list of safety and health hazards identified for this contract and the procedures and method statements for achieving effective and efficient minimisation of the risks associated with such hazards;
- 5.4 The means of minimisation of the effects of climatic exposure (heat, wind and moisture) and an exposure to noxious substances.

6 SAFETY TRAINING

The Contractor shall produce a description of the construction and railway safety training courses that are to be provided. The syllabus, frequency, coverage and application of training courses shall be included together with the means of attaining the objective that all workmen shall be required to attend a safety induction course within their first week on Site and thereafter at times appropriate to their prospective duties and at intervals of not more than six (6) months.

7 SAFETY EQUIPMENT

- 7.1 The Contractor shall identify the safety equipment, rescue apparatus and protective clothing which will be required for the Works.
- 7.2 The identification shall include the quantity, sourcing, standards of manufacture, storage provisions and means of ensuring proper utilisation by all workmen and staff employed directly or indirectly by the Contractor and repair to or replacement of damaged equipment.
- 7.3 Such equipment shall include, but not be limited to: site helmets, goggles and other eye protectors, hearing protectors, safety harnesses, safety equipment for working in confined spaces (e.g. sewers, drains etc.), rescue equipment, equipment to rescue persons from drowning (if applicable), fire extinguishers, first aid equipment, and, where appropriate, suitable fall arrest equipment;

7.4 How safety equipment, scaffolds, guard-rails, working platforms, hoists, ladders and other means of access, lifting, lighting, signing and guarding equipment shall be inspected, tested and maintained and the standards below which such items will be removed from the Site and replaced.

8 CONTRACTOR'S EQUIPMENT

8.1 The Contractor shall produce policy and procedures for ensuring that all his Plant and Equipment used on the works site is maintained in a safe condition and is operated in a safe manner;

8.2 Also, regulations and procedures covering all safety and health aspects of the Works, including where appropriate but not limited to the following:

- a) housekeeping
- b) traffic control and transportation
- c) working on or near operating railways
- d) fire prevention precautions and firefighting equipment
- e) working in confined spaces
- f) excavation
- g) hot working
- h) electrical equipment
- i) welding/cutting operations and equipment
- j) personal protection clothing and equipment
- k) conveyance, handling and use of explosives
- l) cranes
- m) hoists
- n) other lifting appliances
- o) manual lifting
- p) scaffolding and work platforms
- q) ladders
- r) power tools
- s) hand tools and portable power-driven tools
- t) hazardous substances
- u) working over water
- v) working at height
- w) structural steel erection
- x) lighting
- y) protection against falling objects;

9 SUB CONTRACTORS

9.1 The means by which construction and railway safety, rescue and industrial health matters and requirements will be communicated to sub-Contractors of all tiers and their due compliance with the Site Safety Plan and all relevant statutory regulations is ensured;

9.2 The method by which the safety procedures and practices proposed by sub-Contractors will be reviewed for compliance with the Site Safety Plan and statutory regulations including the provision of hazard and risk assessments and method statements.

10 DISCIPLINARY PROCEDURES

The Contractor's disciplinary procedures with respect to dealing with safety related matters both with his own staff and that of sub-Contractors.

11 INCIDENT and ACCIDENT REPORTING

- 11.1 The Contractor's procedure for reporting and investigating incidents, accidents, near misses, dangerous occurrences or occupational illness;
- 11.2 The Contractor's proposals for statistical measurement and monitoring of the safety and health performance of the Contractor and sub-Contractors of all tiers and how such proposals reflect responsible practice in the construction industry.
- 11.3 The means by which the site safety and industrial health performance of the Contractor and sub-Contractors of all tiers can be compared with local and international norms shall be given together with the **suggested rationale for establishing such norms.**

12 FIRST AID EMERGENCIES

The Contractor shall give details of the provision he has made for the operation of the First Aid Base specified in **Appendix 10** and the arrangements he has made for dealing with emergency and disaster situations including liaison with Fire and Ambulance Services.

13 SAFETY PROMOTION

- 13.1 The Contractor shall provide details of the frequency, coverage and intent of site safety meetings together with the rationale for attendance;
- 13.2 The methods of promoting an awareness of site safety and site rescue procedures, and industrial health amongst all persons directly or indirectly associated with the Works;
- 13.3 This shall include proposals for on-site publicity, training courses for all workmen on the Site and at all levels of supervision and management, incentive schemes for the promotion of compliance with safety measures, etc.

14 SITE SECURITY

- 14.1 The Contractor's system for the protection of authorised and unauthorised visitors to the site;
- 14.2 The Contractor's proposals to ensure that construction methods do not compromise the Contractor's commitment to the Site Safety Plan or its compliance with the statutory regulations.

15 INTERFACE with ADY TRAIN OPERATIONS

- 15.1 The Contractor will review the interfaces with ADY Freight Dept. and prepare a specific safety plan for all works that may affect the operating railway.
- 15.2 The Contractor will comply with and incorporate ADY's rules and regulations for track, signalling and operations possessions into his Safety Plan and will operate a permit to work system for all works which may affect the operations of the existing railway.

16 LABOUR SAFETY

- 16.1 These Contractor activities shall be co-ordinate with ADY and shall be in accordance with the applicable legislation in Azerbaijan.
- 16.2 The design and construction shall comply with the applicable legislation in Azerbaijan.
- 16.3 An authorized Contractor expert shall be instructed by relevant ADY experts in the ADY head office. This expert shall instruct all Contractor staff.
- 16.4 The Contractor shall develop appendices for the safety of its labour, for each part of the technical design providing all necessary equipment.
- 16.5 The Contractor shall provide the equipment needed for the labour safety during the **operation of the line.**

APPENDIX 13

ENVIRONMENTAL PROTECTION & SAFEGUARD REQUIREMENTS

1. ENVIRONMENTAL PROTECTION REQUIREMENTS - GENERAL

- 1.1. The Contractor shall mitigate adverse environmental impacts arising from the contract and shall comply fully with all Azerbaijan Environmental Laws and Environmental, Health and Safety guidelines of the International Financial Co-operation (IFC), the directives and recommendations in any Employer provided contamination reports, and acceptable international standards.
- 1.2. The current national standards established by the Ministry of Ecology and Natural Resources (MENR), Government of Azerbaijan and other government agencies for control of environmental pollutants such as air, water, noise and visual impacts/aesthetics shall be followed for compliance during project construction.
- 1.3. The Contractors shall have an Environmental Management Plan, which is approved by the Engineer and endorsed by the Project Implementation Unit (PIU), for all civil and track works design and construction shall comply with and shall be based on all recommendations made in the Initial Environmental Examination (IEE) dated September 2017 including the Environmental Management Plan that forms part of that document. **(See Appendix 25)**
- 1.4. Within 4 (four) weeks of the date of the Date of Commencement, the Contractor shall submit for review and approval by the Engineer, a draft of his own contract specific Environmental Management Plan (EMP).
- 1.5. The designs shall comply with all resolutions specified by the MENR in Resolution No. 4912/2001, as well as forthcoming documents established by the same institution.
- 1.6. The Contractor shall comply with all enactments which shall include but are not limited to:
 - a) Law on Environmental Protection and Utilization of Natural Resources (1992)
 - b) Law on Environmental Protection (June 8, 1999)
 - c) Law on Atmosphere Airs Protection, March 27, 2001
 - d) Law on Protected Areas and Sites (2000)
 - e) Law on Hunting (2004)
 - f) Law on State Ecological Expertise (1996)
 - g) Law on Environmental Safety (1999)
 - h) Water Code of the Azerbaijan Republic (1998)
 - i) Health Protection (1999)
 - j) Law of Azerbaijan Republic on industrial and consumer wastes. (June 30, 1998)
 - k) Land Code of Azerbaijan Republic. June 25, 1999. (and subsequent amendments);
 - l) Water Code of the Republic of Azerbaijan. December 25, 1997. (and subsequent amendment);
 - m) Forests Code of the Republic of Azerbaijan. December 30, 1997 (and subsequent amendments).
- 1.7. The provisions listed herein regarding Environmental Protection shall apply to and be binding upon the Contractor for any works on the site and the persons employed by Sub-Contractors.
- 1.8. The Contractor shall ensure that proper and adequate provisions to this end are included in all sub-contracts placed by him.
- 1.9. The provisions of this Appendix however, shall not be applicable in the case of emergency works necessary for saving of life and property or safety of the Works.

- 1.10. The EMP approved by the Engineer will be submitted to the regional MENR offices for regional approvals, and to the MENR for final approval.
- 1.11. The Contractor shall undertake environmental monitoring as required under the contract, the Employer's IEE, and the MENR resolutions for the project.
- 1.12. Plans Required from Contractor Prior to Construction
 - Air Pollution Control Plan
 - Dust Suppression Plan
 - Water Management Plan
 - Noise Management Plan
 - Flora and Fauna Protection Plan
 - Camp and Workshop Management Plan
 - Facility Layout Plans and Plants Operation Plan
 - Material Source Management and Reinstatement Plan (if new source)
 - Waste Management Plan
 - Site Drainage Plan
 - Soil Management Plan
 - Spill Prevention Plan
 - Community Protection Plan
 - Traffic Management Plan
 - Worker's Health and Safety Plan
 - Grievance Redress Mechanism
 - Cultural, Historical, Archaeological Find and Protection Plan
- 1.13. The Waste Management Plan shall be prepared during design phase, and shall be compliant with National Waste Management Regulation, ADB and international regulation and best practices.
- 1.14. The Contractor shall prepare a plan for self-monitoring and reporting over the course of the project and submit to the Engineer for approval.
- 1.15. The Contractor will consult with the regional offices of MENR, and the in the development of the EMP.
- 1.16. The part of the plan that deals with the monitoring of ground waters will include Contractor monitoring sites located within the sanitary protection areas located within the project area.
- 1.17. The plan approved by the Engineer and endorsed by PIU will be submitted to the MENR for approval within three months after the Date of Commencement.
- 1.18. The plan approved by the MENR will become part of the Contractor's EMP.
- 1.19. The Contractor shall ensure that audits of all the activities detailed in his EMP are carried out at monthly intervals and reported in the Monthly Reports to ensure the continuing effectiveness and compliance with the EMP requirements.
- 1.20. The Contractor shall make available on request any document, which relates to his recent internal audits.

- 1.21. The Engineer may conduct quarterly Audits of the Contractor's EMP and its effective implementation for the Works including any design or site works.
- 1.22. During the audit, the Contractor shall provide a suitable number of qualified staff as directed by the Engineer to accompany the Engineer during the audit.
- 1.23. Requirements established in the EMP specification shall apply to all sites and all activities of the Contractor, including the detailed technical designs of the civil and track infrastructure, and shall supplement the Employer's Requirements.
- 1.24. In the EMP the Contractor will appoint a suitably qualified Environmental Manager and support team for approval by the Engineer. Roles and responsibilities and key communication links must be highlighted to ensure responsibility for implementing the EMP.
- 1.25. The Contractor shall take all precautions to avoid any nuisance arising from his operations, this shall be accomplished, wherever possible by suppression of nuisance at source rather than abatement of the nuisance once generated.
 - a) Following site clearing and before construction, the Contractor shall remove all trash, debris and other weeds.
 - b) The Contractor shall ensure that the work place is free of trash, garbage, debris and weeds. He shall provide and ensure proper uses of refuse containers to ensure that rodents, insects and other pests are not harboured and attracted.
 - c) The Contractor shall provide a dedicated team of workers at each work site who shall be solely employed to keep the site and its environs in a clean condition and maintain a good standard of housekeeping on the site.
 - d) All vehicles leaving the site shall have their wheels washed to prevent any soil or other material from contaminating the public roads.
 - e) The Contractor shall promptly transport all excavation disposal materials of whatever kind so as not to delay work on the project. Stockpiling of materials will only be allowed at sites designated by the Engineer.
 - f) The Contractor shall protect structures, utilities, pavements and other facilities from disfiguration and damage.
 - g) The Contractor's temporary dumping areas shall be maintained by the Contractor at all times until the material is re-utilised for backfilling or as directed by the Engineer.

2. AIR QUALITY

- 2.1. The Contractor shall, so far as reasonably practicable, seek to control and limit emissions to the atmosphere in terms of gaseous and particulate pollutants from vehicles and plant used on the site and dust from construction activities. The Contractor shall identify potential sources of air pollution and apply appropriate mitigation measures including those specified in the IEE.
- 2.2. The Contractor shall develop, implement and maintain a sustainable travel program for all Staff and persons visiting the site to ensure that the impact on air quality and climate associated with private car use is minimized during the Construction Period.
- 2.3. If after the start of construction activity, the Engineer believes that the Contractor's equipment or methods of working are causing unacceptable air pollution impacts then these shall be inspected, and remedial proposals shall be drawn up by the Contractor, submitted for review to the Engineer and implemented.

- 2.4. In the event that approved remedial measures are not being implemented and serious impacts persist, the Engineer may direct the Contractor to suspend work until the measures are implemented, as required under the Contract.
- 2.5. The Contractor shall not use, for temporary or permanent works, any refrigerant, chemicals or other material, which will produce contaminated gases or air not acceptable under environmental standards. In this respect, there is no prohibition in the Azerbaijan legislation to use the gas SF6 in the high-voltage switchgear.
- 2.6. Emissions of Greenhouse gases should be minimized by the Contractor through the use of energy efficient technologies where appropriate, as well as the correct maintenance of vehicles and plant.

3. DUST SUPPRESSION

- 3.1. The Contractor shall not allow emissions of fugitive dust from any transport, handling, construction or storage activity to remain visible in atmosphere beyond the property line off emission source for any prolonged period of time without notification to the Engineer.
- 3.2. The Contractor shall use construction equipment designed and equipped to minimise or control air pollution. He shall maintain evidence of such design and equipment and make this available for inspection by the Engineer.
- 3.3. The Contractor shall inspect and review all dust sources that may be contributing to air pollution.
- 3.4. Remedial measures can include use of additional and/or alternative equipment by the Contractor or maintenance/modification of existing equipment of the Contractor.
- 3.5. Dust generating materials shall be:
 - a. Transported in closed containers or covered trucks;
 - b. Stored, loaded and unloaded in closed systems or wind protected areas;
 - c. Watered as appropriate to minimise dust production.
- 3.6. The Contractor's transport vehicles and other equipment shall conform to emission standards fixed by Statutory Agencies of Government of Azerbaijan.
- 3.7. The Contractor shall carry out periodical checks and undertake remedial measures including replacement, if required, so as to operate within permissible norms.
- 3.8. Records shall be kept of routine maintenance programs for internal combustion engine powered vehicles and equipment used on this project and such records shall be available for inspection by Engineer.
- 3.9. The Contractor shall be responsible for ensuring that no earth, rock or debris is deposited on public or private right-of-way as a result of his operations, including any deposits arising from the movement of loaded/unloaded trucks and/or Other construction vehicles.
- 3.10. The Contractor shall make his own arrangements for water for purposes stated in above clauses and wherever it may be required to control air pollution, dust and debris.

- 3.11. The Contractor shall water down construction sites as required to suppress dust, during handling of excavation soil or debris or during demolition.
- 3.12. The Contractor shall place material in a manner that will minimise dust production and the material shall be stabilised each day and wetted, to minimise dust production.
- 3.13. During dry weather, dust control methods must be used daily especially on windy, dry days to prevent any dust from blowing across the site perimeter.
- 3.14. Dust control activities shall continue during any work stoppage.
- 3.15. The Contractor shall design and implement his blasting techniques so as to minimise dust generation.

4. WATER MANAGEMENT

- 4.1. The Contractor shall implement a water management plan to provide a co-ordinated approach to water management for the design and construction stage.
- 4.2. Water consumption shall be metered and reported in Contractors monthly and quarterly reports.
- 4.3. Prior to changing the routes of any major surface water bodies, the Contractor will undertake further work to predict potential impacts and ensure that appropriate mitigation is included within the Contractor's EMP.
- 4.4. The EMP will identify these areas, the work required and proposed mitigation strategy throughout the process to ensure potential impacts throughout the whole design process and construction process are minimised.
- 4.5. The Contractor shall ensure that all alterations to irrigation canals will be co-ordinated with local irrigation system area and shall ensure that scheduling such alterations avoids the irrigation season.
- 4.6. The Contractor shall undertake further work to determine flooding risks and ensure that drainage operations are optimised.
- 4.7. Areas that are prone to flooding will be identified and an appropriate mitigation strategy developed and agreed with the relevant authorities prior to construction beginning.
- 4.8. Recommendations from this flooding investigation work will be included within the Contractor's EMP.
- 4.9. The Contractor shall monitor for groundwater contamination within the sanitary protection areas near the site.
- 4.10. The Contractor shall provide adequate precautions to ensure that no spoil or debris of any kind is pushed, washed, falls or deposited on land or watercourses adjacent to the site perimeter, unless agreed by the Engineer.

- 4.11. In the event of any spoil or debris from construction works being deposited on land near a watercourse, or any silt washed down to any such area, then all such spoil, debris or material and silt shall be immediately removed, and the affected land and areas restored to their natural state by the Contractor to the satisfaction of the Engineer.
- 4.12. The Contractor will define within the EMP in detail the management solutions that will be adopted to prevent particles and debris and other contamination entering water bodies or wells, these may include the use of filters and sedimentation basins as required.
- 4.13. The Contractor shall provide treatment facilities as necessary to prevent the discharge of contaminated water to ground.
- 4.14. The Contractor shall at all times ensure that all existing stream courses and drains within, and adjacent to the site are kept safe and free from any debris and any excavated materials arising from the Works.
- 4.15. The Contractor shall ensure that earth, chemicals and concrete agitator washings etc. are not deposited in the watercourses but are suitably treated and effluents and residue disposed of site in a manner approved by local authorities.
- 4.16. All water and waste products (surface run-off and wastewater) arising on the site shall be collected and removed from the site via a suitable and properly designed temporary drainage system and disposed of at a location and in a manner, that will cause neither pollution nor nuisance.
- 4.17. Any mud slurry from drilling, tunnelling, pile construction or grouting etc. shall not be discharged into the drainage system unless treatment is carried out that will remove silt, mud particles, bentonite etc.
- 4.18. Where possible the Contractor shall discharge wastewater arising out of site office, canteen or toilet facilities constructed by him into sewers after obtaining prior approval of agency controlling the system.
- 4.19. A wastewater drainage system shall be provided to drain wastewater into the sewerage system.
- 4.20. Oil removal/interceptors shall be provided to treat oil waste from workshop areas etc.
- 4.21. The Contractor shall ensure that all potentially hazardous materials are appropriately stored within contained and bounded areas.
- 4.22. The Contractor will ensure that spill response equipment is available in the event of an accidental discharge and will provide training in the use of this equipment.
- 4.23. The Contractor shall ensure that pesticides and herbicides are not used adjacent to surface watercourses.
- 4.24. Management of such materials shall be detailed within the EMP and training of staff using materials will be required and details of such training provided as part of the above.
- 4.25. The Contractor shall ensure that all dismantled structures are removed to areas that will not impede river flow systems.

- 4.26. The Contractor shall specify a procedure for all dismantling processes, which will be included within the EMP.
- 4.27. The Contractor shall ensure that dewatering works do not affect locally important potable ground water resources.
- 4.28. For each water site affected, a separate water management plan in accordance with the requirements of MENR will be submitted to the Engineer for approval.
- 4.29. The water management plans will be submitted to MENR for final approval.

5. NOISE

- 5.1. The Contractor shall comply with impact criteria were adopted with reference to guideline values set out in the BS 5228 (Façade Noise Level, 1hr 80 dB (Daytime)) standard and other common practice standards around the world.
- 5.2. The Contractor shall take all appropriate measures to ensure that work carried out by the Contractor and by his sub-Contractors, whether on or off the Site, will not cause any unnecessary or excessive noise which may disturb the occupants of any nearby dwellings, schools, hospitals, or premises with similar sensitivity to noise. Work near Sensitive Receptors (identified in this IEE) shall be limited to short term activities; temporary noise barriers could be provided in front of these sensitive buildings.
- 5.3. Construction activities will be strictly prohibited between 10 PM and 6 AM in the residential areas.
- 5.4. Without prejudice to the generality of the foregoing, noise level reduction measures shall include the following:
 - a) All powered mechanical equipment used in the Works shall be effectively sound reduced using the most modern techniques available including but not limited to silencers and mufflers.
 - b) Acoustic screens or enclosures shall be constructed around any parts of the Works from which excessive noise may be generated.
 - c) Noise-absorbing cover shall be scrutinized as noise protection fence alternative.
 - d) Noise protection fence shall be aesthetic developed and shall not divide architecturally and visually the towns and villages.
 - e) Noise diagrams shall be prepared in accordance with IFC noise level standard.
- 5.5. The Contractor shall ensure that noise generated by work carried out by the Contractor and his sub-Contractors during daytime and night-time shall not exceed the maximum permissible noise limits, whether continuously or intermittently, as set out in the approved EMP.
- 5.6. In the event of a breach of this requirement, the Contractor shall immediately re-deploy or adjust the relevant equipment or take other appropriate measures to reduce the noise levels and thereafter maintain them at levels, which do not exceed the said limits.
- 5.7. Such measures may include without limitation the temporary or permanent cessation of use of certain items of equipment, or other suitable mitigation measures to reduce the noise levels to an acceptable level for occupants of buildings in the vicinity of the construction activities.

- 5.8. The Contractor shall ensure that baseline measurements shall be taken at each populated area, station, and halt prior to beginning of construction to allow auditing measures to be successful. Note: The IEE in the section: “Description of the Environment (Baseline Data) - Table 11”, has baseline daytime measurements for noise at six (6) locations which can be used for auditing if the Contractor does not provide their own agreed baseline measures for those locations. Other locations shall require baseline measurements to be taken by the Contractor.
- 5.9. The noise monitoring requirements, including monitoring locations shall be defined in the Contractor’s EMP.
- 5.10. As part of the detailed technical Design of Civil and Track Works infrastructure, the Contractor shall establish the criteria for acceptable noise levels at each populated area, Stations and incorporate in the detailed technical design mitigation measures for each location, and other receptor areas determined during the design.
- 5.11. The noise mitigation plan and the effectiveness of the noise protection measures will be assessed and reported to the Engineer in a detailed Noise Management Plan (NMP), prepared as part of the Contractor’s EMP.
- 5.12. The NMP shall include full and comprehensive details of all powered mechanical equipment, which the Contractor proposes to use during daytime and night-time and of his proposed working methods and noise level reduction measures.
- 5.13. The NMP shall include detailed noise calculations to demonstrate the anticipated noise generation by the Contractor.
- 5.14. The NMP shall be a guide for the implementation of construction activity. The NMP will be reviewed on a regular basis and updated as necessary to ensure that current construction activities are addressed.
- 5.15. Noise Monitoring & Control will appear as a regular agenda item in project co-ordination/progress meetings.
- 5.16. The NMP that is approved by the Engineer will be submitted to the MENR for final approval.
- 5.17. Approval of the overall design will be contingent on the approval of the NMP.

6. CONTROL REQUIREMENTS

- 6.1. Under the Contract, the Contractor shall perform work within the procedures outlined herein and comply with applicable codes, regulations, and standards established by the Azerbaijan Government and their agencies.
- 6.2. Schedule and conduct operations in a manner that will minimise, to the greatest extent feasible, the disturbance to the public in areas adjacent to the construction activities and to occupants of buildings in the vicinity of the construction activities.

7. VIBRATION LEVEL LIMITS

7.1. The vibration level limits adjacent to the alignment shall conform to applicable norms and standards foreseen in Urban Planning and Construction Code of Azerbaijan, and other acceptable international standards for vibration management, e.g. German Standard DIN 4150-2, 1999, Structural vibration – Part 2.

- a) Construction vibration in relation to human response:
- The vibration shall be measured near the centre of any occupied sensitive room of an inhabited building.
 - Between the hours of 07h00 and 23h00 (Monday to Saturday) construction vibration shall not exceed the specified vibration limits as follows:
 - KBFmax 5 mm/s
 - KBFT_r 0.4mm/s in any evaluation period, except where work does not cause disturbance, where disturbance is defined as any complaint made by any person who is the occupant of a sensitive room in an inhabited building.
 - At all other times construction vibration shall not exceed the specified vibration limits as follows:
 - KBFmax 0.2 mm/s (0.15mm/s in hospitals)
 - KBFT_r 0.05 mm/s in any evaluation period except where work does not cause disturbance, where disturbance is defined as any complaint made by any person who is the occupant of a sensitive room in an inhabited building.
- b) Construction vibration in relation to building response:
- Continuous vibration in relation to building response shall not exceed the following limits in any building according to Azerbaijani Standards, except in the cases of reinforced or framed structures, industrial and heavy commercial buildings. A peak particle velocity limit of 25mm/s shall apply.
 - Below 4 Hz maximum displacement 0.3mm (zero to peak)
 - 4 Hz – 15 Hz 5mm/s peak particle velocity at 4Hz increasing to 10mm/s at 15 Hz
 - 15 Hz and above 10mm/s peak particle velocity at 15Hz increasing to 25mm/s at 40Hz and above
 - Transient vibration in the frequency range of the predominant pulse shall not exceed the following limits, except in the cases of reinforced or framed structures, industrial and heavy commercial buildings. A peak particle velocity limit of 50mm/s shall apply
 - Below 4 Hz maximum displacement 0.6mm (zero to peak)
 - 4Hz-15Hz 5mm/s peak particle velocity at 4Hz increasing to 20mm/s at 15 Hz
 - 15Hz and above 20mm/s peak particle velocity at 15Hz increasing to 50mm/s at 40Hz
- c) Construction vibration in relation to Sensitive Equipment:
- It shall be the responsibility of the Contractor to identify all sensitive equipment, whether identified by the Engineer or not, that may be affected by the Works. Furthermore, the Contractor shall be responsible for ensuring that vibration limits do not exceed the relevant
 - It shall be the responsibility of the Contractor to identify all sensitive equipment, whether identified by the Engineer or not, that may be affected by

the Works. Furthermore, the Contractor shall be responsible for ensuring that vibration limits do not exceed the relevant limits at the sensitive equipment or shall provide appropriate mitigation measures. Unless otherwise defined in respect of identified sensitive equipment, vibration at the base or foundation of any sensitive equipment shall not exceed a RMS vibration velocity in any 1/3 octave band from 4 Hz to 80 Hz of 12 $\mu\text{m/s}$.

- The Contractor shall comply with the specific limits set out in third party agreements.

7.2. The scheme for monitoring the vibration level at the site shall be submitted to the Engineer for approval.

7.3. The scheme shall include:

- a) Monitoring requirements for vibrations at regular intervals throughout the construction period;
- b) Preconstruction structural integrity inspections of historic and sensitive structures in project activity;
- c) Information dissemination about the construction method, probable effects, quality control measures and precautions to be used.

8. WASTE

8.1. The Contractor shall minimize the generation of waste for the duration of the Contract. All waste shall be managed in compliance with International Financial Co-operation guidelines (e.g. encouraging waste segregation), as well as National Azerbaijani Regulations and Standards.

8.2. The Contractor shall develop a detailed Ground Investigation and Site Characterization Survey, based on the findings of the preliminary surveys developed by ADY, in order to determine the required mitigation actions concerning the polluted land, according to Azerbaijani Standards, Regulations, Policies and Procedures. The Contractor will prepare a specific Mitigation Plan about the treatment or removal of the polluted land (or a selected part of it). The Contractor will obtain approval for the Plan from the Relevant Authorities. However, the document will also be introduced in the review procedure, in order to obtain the mandatory validation from the Engineer designated by ADY.

8.3. The Contractor will develop a Waste Management Plan which will form part of the Contractor's EMP, prior to beginning of construction. The scheme shall ensure the following as a minimum:

- a) The contractor shall be committed to ensure correct and safe management of the waste generated as a result of construction works and commissioning activities.
- b) The Waste Management Plan shall be prepared during design phase, and shall be compliant with National Waste Management Regulation, ADB and international requirements and best practices.
- c) The Contractor shall handle waste in a manner that ensures waste materials are held securely without loss or leakage thus minimising potential for pollution.
- d) The Contractor shall remove waste in a timely manner.

- e) Scrap and waste material shall be removed and disposed of at landfill sites after obtaining the approval of the MENR for its disposal.
- f) The Contractor shall not burn debris or vegetation or construction waste on the site but remove it in accordance with (b) above.
- g) The Contractor will ensure that all site waste material that may be recycled in a cost effective manner will be disposed of through local businesses capable of economically using the site waste material.
- h) The Contractor shall ensure a demolition waste materials area for the Contractor's disposal of demolition waste, and remove all waste before the completion of the Contract and restore the area to its previous state.
- i) The Contractor shall maintain and clean waste storage areas regularly.
- j) The Contractor shall ensure that all buildings scheduled for demolition currently on-site will be externally audited before demolition takes place. Auditing requirements shall include as a minimum:
 - Asbestos;
 - PCB's;
 - Oils;
 - Contaminated Ground Area.
- k) The Contractor will ensure that all waste sludge's are recycled or remedied where practical as described within the disposal procedures. Where necessary ultimate disposal will be via high temperature incineration or disposal to controlled landfill.

8.4. If encountered or generated as a result of the Contractor's activity, then waste classified as hazardous will require specific handling and they have to be transported to National Hazardous Waste Centre for treatment or disposal.

8.5. The Contractor will prepare specific handling and disposal procedures and submit these for the Engineer's approval prior to removing any such material off-site.

9. LANDS AND SOILS

9.1. The Contractor shall draw up a technical and biological re-cultivation plan for habitat restoration of construction sites to be implemented after cessation of the Works, which shall be undertaken in accordance with MENR resolutions on landscaping and re-cultivation.

9.2. All site habitat restoration projects shall include as a minimum:

- a) A description of functional land use project
- b) A technical plan outlining material needed, formation of landscaping and the transportation procedures necessary for effective completion
- c) A description and possible environmental impacts of the technical facilities necessary for completion of the project
- d) All measures necessary for soil rehabilitation

9.3. Where the existing railway is removed, the soil bedding under the existing sleepers will be excavated. According to MENR resolutions on the IEE, cleaning through chemical treatment

and/or bio-remediation should be undertaken if the level of pollutants is shown to exceed the MENR requirements.

10. GEOTECHNICAL ISSUE

- 10.1. The Contractor shall submit within the EMP the expected construction impacts for all major facilities and sections of higher embankments and deeper excavations, including materials used for the building of the embankment prior to construction, these impacts should include:
- a) Determination of embankment material quality and placement impact;
 - b) Stability factors, including seismic migration;
 - c) Drainage facilities for groundwater dewatering;
 - d) Effects on the local communities and transportation networks from overland truck transport of fill and excavate to and from the specific borrow and fill sites.
 - e) Specific mitigation measures and maintenance-of-traffic plans to ensure minimal disruption on local traffic conditions and the environment shall be included in the EMP;
 - f) A program schedule of excavation, disposal and fill activities, including transport, shall be set out in the Contractor's EMP for the entire period of the construction, and the program will include the treatment of soil defined in 6, above.

11. FLORA AND FAUNA

- 11.1. The Contractor shall minimize any adverse environmental impacts on ecology (flora and fauna).
- 11.2. The Contractor shall develop, implement and maintain Flora and Fauna Protection Plan best international practice. Azerbaijani Standards and Regulations shall be adhered to with particular attention given to the most appropriate timing for undertaking bat surveys.
- 11.3. A suitably qualified and experienced environmental specialist shall be responsible for the implementation of the mitigation measures.
- 11.4. The Contractor shall ensure that an ecological survey is undertaken within the woodland areas referenced within the IEE, before clearing is carried out.
- 11.5. If necessary, suitable measures to minimize impacts should be included within the Contractor's EMP and possible mitigation measures outlined shall be given due consideration before woodland is destroyed.
- 11.6. The Contractor shall develop site limits beyond which no personnel or machinery will pass. These limits will be clearly shown to all site personnel, these limits will be set in order to prevent to prevent illicit tree felling outside of the construction site and pollution or compaction of the upper humus horizon.
- 11.7. Contractor shall record existing vegetation levels and types before construction camp development, this will be used for re-cultivation of disturbed areas after dismantling of construction facilities.
- 11.8. The Contractor shall ensure inclusion of findings and recommendations of a Zoologist into the EMP, to provide advice on how to manage fauna, and in particular any fauna threatened with extinction within the project region and the relevant requirements to manage fauna in accordance with the applicable Azerbaijan legislation.

- 11.9. The Contractor shall plant fast growing vegetation species along water courses to minimise the potential for soil erosion, ensuring all these species shall be native to Azerbaijan and the local region.
- 11.10. An initial inspection program shall be set up by the Contractor for all terrain in close proximity to the railway to determine baseline measures of disease and pest spread.
- 11.11. All tree felling shall be undertaken by skilled tree surgeons.

12. CULTURAL AND HISTORICAL HERITAGE

- 12.1. The Contractor shall establish border zones around all project affected registered archaeological sites with the assistance of the relevant archaeological authorities.
- 12.2. The Contractor shall ensure that the station building at Khachmaz (35m from the track), has site specific issues developed and incorporated into the Contractor's EMP to ensure protection of this historical building.
- 12.3. The Contractor shall ensure that all site activities will cease upon discovery of archaeological artefacts and sites to allow the relevant archaeological authorities to determine the site significance and allow for recording of details.
- 12.4. The Contractor shall take into consideration the requirements from any study done by the Archaeological institute and museum.
- 12.5. The Contractor shall provide protection/excavation/removal of monuments including supervision of archaeological works and route to ensure the continuing effectiveness and compliance with the Contract.

APPENDIX 14

RELIABILITY, AVAILABILITY, MAINTAINABILITY & SAFETY (RAMS)

1. GENERAL

- 1.1 The Project is to be designed with a high degree of safety, reliability and availability, in order to provide a safe and dependable service that freight forwarders and the public will want to use, thereby increasing patronage and revenues from the system. However, these parameters impact on the operating and maintenance costs and various factors need to be addressed in order to maximise the financial returns from the system.
- 1.2 The optimisation of the system with respect to reliability, availability and maintainability must be planned and must form an integral element of the project from its inception through to its operational life as the 'whole life cost' of a major system is an aspect which in the long-term can affect the financial viability of the project.
- 1.3 The Contractor shall demonstrate that the issues of RAM will be managed during all phases of the project.
- 1.4 The RAM management process shall address all aspects of the System and must be demonstrably integrated into the project as a whole and this is to be achieved through the development of a process that as a minimum shall address the following:
 - a) Definition of RAM requirements.
 - b) Planning and implementation of RAM tasks for all project phases.
 - c) Assessment and control of impacts and threats to RAM requirements.
 - d) Demonstration of compliance with RAM requirements.
 - e) Program of ongoing monitoring of compliance.
 - f) Applying of the Azerbaijan standards, norms, regulations, instructions and Employer requirements.
 - g) Operational compatibility with the neighbouring railway sections and electrical locomotives.
- 1.5 This Appendix provides the scope of the processes related to RAM management for the project.

2. DEFINITIONS

- 2.1 The following terms define the relationships between the key parameters that are to be specified and managed.
- 2.2 These parameters are not to be used interchangeably and must be used in the correct context in all documentation and the definitions of relevance are:
 - a) Reliability is the probability that an equipment item or system can perform a required function under given conditions for a given time interval.
 - b) Availability is the probability that an equipment item or system is in a state to perform a required function under given conditions over a given time interval, assuming that the required external resources are provided.
 - c) Maintainability is the probability that a given active maintenance action, for an item of equipment or system under given conditions of use, can be carried out within a stated time interval when the maintenance is performed under stated conditions and using stated procedures and resources.
- 2.3 In more general terms, the reliability of a system is a measure of its failure frequency, the availability is a measure of system actual up time compared to total scheduled time for operation, and the maintainability is a measure of the time taken to reinstate the system following failure.

3. RAM MANAGEMENT PROGRAMME

- 3.1 The RAM programme shall be integrated into the overall Project Programme so that the results, recommendations and insights from the detailed RAM studies will influence the development of the project as a whole.
- 3.2 The RAM specification shall be developed early in the project programme and submitted with the Preliminary Design Submittal to enable these elements to be included in the contract documents for the project's main systems suppliers, since much of the detailed assessment will be conducted by these suppliers who will be responsible for the detailed design, manufacture, installation and commissioning of equipment and systems.
- 3.3 The management process will not only identify the technical assessments to be undertaken but also relate these to the overall project program,
- 3.4 Outlines of the studies that will be expected during the project to demonstrate the achievement of the specified targets are given in the following Table for the key project phases,
- 3.5 The particular activities to be undertaken will vary from system to system and will also be dependent on the complexity, degree of risk, timescale constraints, areas of new or existing designs and technology, etc.
- 3.6 The list is to be considered as indicative of the types of study that will be expected to form the technical program.

Project Phase	RAM activities
Concept Design.	Specification of: <ul style="list-style-type: none"> • Reliability performance targets; • Availability performance targets; • Maintainability performance targets; • System performance target allocation studies
Preliminary Design.	Development of Concept Design targets
Definitive Design Development.	Reliability/Availability: <ul style="list-style-type: none"> • Developed reliability models • Developed availability models • Data collection, analysis and feedback • Reliability growth testing • Verification of achievement of specified targets • Report Maintainability: <ul style="list-style-type: none"> • Maintenance design reviews Ergonomic reviews • Reliability Centred Maintenance studies Verification of achievement of specified targets • Report Final RAMS Report
Implementation, installation construction and commissioning.	Reliability demonstrations Maintainability demonstrations Data collection, analysis and feedback Updating of RAM assessments

4. SYSTEM RAM TARGETS

- 4.1 The Contractor shall develop designs for the System such that it will provide a high level of dependability and the public will have confidence in the service provided.
- 4.2 The System shall comply with EN 50126 "railway applications".
- 4.3 The specification shall be a demonstration of Reliability, Availability, Maintainability and Safety (RAMS) including: demonstration journey during the testing, testing with measuring laboratories of the line, at design speed of 154 km/hr (140km/h+10%), for the testing journey.
- 4.4 The basic criteria against which the system is to be developed is that the system must and can transport the projected peak period rider-ship at the quality level defined in the Operational Requirements.
- 4.5 During non-peak hours, the service provided must be demonstrably flexible to meet the varying levels of demand.
- 4.6 Reliability criteria must reflect the need to develop a system that does not suffer from frequent 'nuisance type' failures (i.e. short delays or degraded service).
- 4.7 Availability criteria must reflect the expectations of the railway operators, freight forwarders, and passengers in that the scheduled service must be available for a very high percentage of the time.
- 4.8 The Contractor is free to choose any combination of system parameters to develop a system to meet the above basic requirements, however, the Contractor should take full account of the impact that all parameters will have on 'overall lifetime cost', which should be as low as reasonably practical.
- 4.9 The Contractor will be required to demonstrate the manner and logic used in developing the system parameters to meet the above criteria.

5. SYSTEM RAM PLAN

- 5.1 The Contractor shall submit, as part of the Concept Design Submittal to the Engineer for his consent, a System RAM Plan. This Plan shall:
 - a) discuss the way the Track Work System requirements are allocated to all the Rail System elements (e.g. power supplies, signalling, rolling stock, etc.);
 - b) show the preliminary allocations made to each element;
 - c) discuss the various trade-offs which may need to be made; and
 - d) explain the Contractor's approach to resolving conflicts.

6. AVAILABILITY TARGET

- 6.1 The availability target for the Track Work system is defined below:

Failure Category	Impact (minutes)	MTTR	MTBF	Sumgayit to Gil-Gil-Chay Line	Unavailability
Serious delay \geq 30 minutes delay	120	120	1.14E-04	Entire length	1.14E-04
Service Availability					99.9888%

7. SAFETY TARGET

- 7.1 No specific safety targets have been defined for Track Work. The Contractor shall take the hazard related information that he has determined for the Project and develop further specific hazards related to Track Work to ensure that all hazards relating to Track Works are eliminated or mitigated to a level considered “So Far As Is Reasonably Practical” (SFAIRP).

APPENDIX 15

POSSESSION MANAGEMENT

1. GENERAL

- 1.1 The Contractor shall comply with the possession management system operated by ADY, including the protection associated with HV overhead 3 kV DC respectively 25 kV AC, 50Hz Catenary electrification.
- 1.2 The Contractor shall appoint a responsible person who shall co-ordinate with ADY and who will act as the Possession Coordinator.
- 1.3 The person appointed must have experience of ADY train operations and must be fully aware of ADY Rules and Regulations related to possession of track for construction of railway works and in accordance with ADY regulations to issue possession requests.
- 1.4 For the purpose, he shall be duly certified in accordance with the said rules.

2. POSSESSION PERIODS

- 2.1 The Contractor may use possessions on the line as follows:
 - a) For the Lot 1 section between Sumqayit and Gil-Gil-Chay stations, the Track under construction shall be not available for Operation Train 24h/24h but authorised for Work Trains under the Contractor's responsibility and the adjacent track should use with 4 hours possession periods that may be available for works within the railway envelope, with varying hours during daily low traffic periods including clearance periods of 15 minutes at the beginning and end of each possession, seven days per week.
 - b) For the remainder of the line the possessions may be envisaged on a similar basis as in a) above, however these shall be subject to agreement between the Contractor and the ADY.
 - c) For each possession and depending on the duration and the location of the possession alternative passenger transport may be required, and where provided this alternative transport will be at the Contractor's cost.
 - d) The normal alternative mode of transport will be by bus and the route and timings of this alternative transport is to be agreed with the ADY prior to obtaining the possessions.
- 2.2 Temporary line closures may be agreed subject to ADY approval.
- 2.3 The Employer gives no warranty that the above line closures and possession periods will be available during the period of the Works.
- 2.4 The Employer will however provide any assistance necessary to the Contractor to enable him to obtain the line closures and possessions required by him for the Works.
- 2.5 The Contractor shall prepare technological and organisational schedule for construction which shall include the work times in the weekends and during the dark part of the day.
- 2.6 The Contractor shall submit his requests for 'possessions' at least one month earlier and inform ADY at least 24 hours earlier if he is not able to use the permitted 'possessions'

3. TRACK POSSESSION PERSONNEL

- 3.1 The Contractor shall appoint a responsible person who shall co-ordinate with ADY and who will act as the Track Possession Coordinator.
- 3.2 The Contractor shall provide railway safety trained personnel to oversee, supervise and report on each and every Track Possessions, on a full-time basis. At each station located at the beginning and end of a Track Possession, or if the Track Possession is in a station, the Contractor shall have at least one full-time person located at that location to co-ordinate and relay messages from ADY to the Contractor's personnel (and vice-versa) working on the possession.
 - b. Each of these personnel shall be termed a Contractor's Operations Person In-Charge (COPIC) and shall report to the Contractor's Track Possession Coordinator.

APPENDIX 16

STANDARDS AND CODES FOR CIVIL & TRACK

The following order of precedence for Standards and Codes used for this Contract shall be followed:

1. Azerbaijan National Standards
2. AzDTN/GOST, SNIP
3. UIC Standards and Leaflets
4. European Standards (EN);
5. IEC Standards;
6. ASTM
7. Other standards which are recognised for international use;

The design standards and codes for civil & track shall include but not be limited to those set out in the following tables. The Contractor can propose alternate standards to the Employer for consideration.

Standard / Code	Alignment and Permanent Way
General	
96/48/EC	European Council Directive on the interoperability of the Trans-European high-speed rail system
AGC	European Agreement on the International Railway Line
AGCT	European Agreement on Important International Combined Transport Lines and Related Installations
Civil Works and Permanent Way	
UIC 0 A15	Execution and management of projects (Article 51)
UIC 0 A17	Mandatory provisions and recommendations (Article 65)
UIC 171	Guidelines for Railway Bridges
UIC 505-1 OR	Railway transport stock -rolling stock construction gauge
UIC 505-4 ORI	Effects of the application of kinematic gauges defined in the 505 series of leaflets on the positioning of structures in relation to the tracks and of the tracks in relation to each other
UIC 505-5 01	Basic conditions common to Leaflets 505-1 to 505-4. Notes on the preparation and provisions of these leaflets
UIC 506 OR	Rules governing application of the enlarged GA, GB, and GC gauges
UIC 508--1 R	Interaction between passenger rolling stock and fixed installations

UIC 513 OR	Guidelines for evaluating passenger comfort in relation to vibration in railway vehicles
UIC 518 OR	Testing and approval of railway vehicles from the point of view of their dynamic behaviour - Safety - Track fatigue - Ride quality
UIC 521 0	Coaches and vans, wagons, tractive stock -Clearance to be provided at vehicle extremities
UIC 527-1	Coaches, vans and wagons - Dimensions of buffer head - Track layout on S-curves
UIC 606-1 OR	Consequences of the application of the kinematic gauges defined by UIC leaflets in the 505 series on the design of the contact fins
UIC 700 0	Classification of lines and resulting load Limits for wagons
UIC 703 R	Layout characteristics for line used by fast passenger trains
UIC 710 R	Slacking of the track gauge on curves
UIC 711 R	Geometry of points and crossings with UIC rails permitting speeds of 100 km/hr or more on the diverging track
UIC717R	Recommendations for the design of bridges to satisfy track requirements and reduce noise dimensions
UIC 717-3 R	Steel bridges - Laying of track without ballast - Direct laying
UIC 718-1 R	Criteria to be taken into consideration when approving mechanical track maintenance equipment
UIC 719 R	Earthworks and tracked construction for railway lines
UIC 720 R	Laying and maintenance of track made up of continuously welded rails
UIC 722 R	Methods of improving the track formation of existing lines
UIC 723 R	Selection and application of herbicides on track superstructure with due consideration for environmental protection
UIC 755-1	Cable Ducts
UIC 760 OR	Level crossings - Road signs and signals
UIC 761 1	Level crossings - Technical directives for the automatic operation of or warning to level crossings

UIC 762 R	Safety measures to be taken at level crossings on high-speed lines
UIC 771 R	Geometry of points and crossings with UIC rails permitting speeds of 100km/hr or more on the diverging track
UIC 861-2 0	Standard sections for points rails adapted to UIC 54 and UIC 60kg/m rail sections
UIC 861-3 0	Standard 60kg/m rail profiles - Types UIC 60 and 60E
UIC 864-8 V	Rolled profiles for fishplates for 54kg/m and 60kg/m rails
Structures	
AZN10	Azerbaijan Seismic Building Code
EN 1991	Eurocode 1 Basis of design and actions on structures
EN 1992	Eurocode 2 Design of concrete structures
EN 1993	Eurocode 3 Design of steel structures
EN 1994	Eurocode 4 Design of composite steel and concrete structures
EN 1995	Eurocode 5 Design of timber structures
EN 1996	Eurocode 6 Design of masonry structures
EN 1997	Eurocode 7 Geotechnical design
EN1998	Eurocode 8 Design of structures for earthquake resistance
EN 1999	Eurocode 9 Design of aluminium alloy structures
ENV 1991-3/AC	Eurocode 1: Basis of design and actions on structures Part 3: Traffic loads bridges
UIC 702 0	Loading diagram to be taken into consideration for the calculation of rail-carrying structures on line used by international services
UIC 771-1 R	Rolled steel
UIC 771-2 R	Steel grades
UIC 771-3 R	Rail bearers
UIC 772-1 R	Bearings
UIC 772-2 R	Rubber bearings

UIC 772 R	Concrete joists
UIC 774-1 R	Recommendations for the design of railway bridge's in reinforced and pre-stressed concrete
UIC 774-2 R	Distributions of axle loads on ballasted railway bridges
UIC 774-3 R	Longitudinal forces
775 R	Use of welding
UIC 776-1 R	Loads to be considered in railway bridge design
UIC 776-2	Bridges for very high speeds
UIC 776-3 R	Deformation of bridges
UIC 776-4-R	Computer aided calculation of bridges
UIC 777-1 R	Measures for the protection of railway bridges against impact from road vehicles and for limiting the damage caused
UIC 777-1 R	Over bridges
UIC 778-1 R	Recommendations for the consideration of fatigue in the design of steel railway bridges
UIC 778-2 R	Carrying capacity of existing bridges
UIC 778-3 R	Load capacity of masonry & mass concrete arch bridges
UIC 778-4 R	Defects in rail bridges
UIC 779-1 R	Slipstream effects
UIC 779-11 OR	Tunnel cross sections-slipstream
UIC IF 3/89	Defects in railway bridges and procedures for maintenance and strengthening
UIC IF 5/91	Admission of higher curving speeds for special trains
UIC IF 6/96	Safety assessment for components at risk from impact-Developments with superstructures
UIC 965 R	Instructions governing the behaviour and safety of staff working on the track
UIC 896-2	Recommendations for the protection of steel structures against corrosion
R UIC 901 -1	Use of polymeric materials for railway superstructures and infrastructure and in Project Management structures
UIC IF 7/96	Maintenance of high-speed lines

STATE STANDARD OF THE REPUBLIC OF AZERBAIJAN

Main requirements for design and working documents

AZS GOST 21.101-2010

1 APPLICATION AREA

This standard identifies main requirements for different purpose concerns, design and workers documents for building of buildings and infrastructures.

Graph and text stated in the 5th chapter of current standard concerns to the general rules of document realization, also to the reports of technical documents according to engineer search for construction.

2 REFERRED STANDARD DOCUMENTS

It has been referred to the following standards during the usage of current standards:

GOST 2.004—88 ЕСКД. General requirements for performing design and technological documents on printing and graphical output devices of computers

GOST 2.101—68 ЕСКД. Sorts of products

GOST 2.102—68 ЕСКД. Types and completeness of design documents

GOST 2.105—95 ЕСКД. General requirements for text documents ГОСТ 2.108—68 ЕСКД. Specification

GOST 2.109—73 ЕСКД. Basic requirements for drawings

GOST 2.113—75 ЕСКД. Group and basic design documents

GOST 2.114—95 ЕСКД. Technical specifications

GOST 2.301—68 ЕСКД. Formats GOST

2.302—68 ЕСКД. Scales

GOST 2.303—68 ЕСКД. Lines

GOST 2.304—81 ЕСКД. Drawing fonts

GOST 2.305—68 ЕСКД. Images - types, cuts, sections

GOST 2.306—68 ЕСКД. Designation of graphic materials and rules for their representation on drawings

GOST 2.307—68 ЕСКД. Dimensions and limit deviations

GOST 2.308—79 ЕСКД. The indication on the drawings of tolerances of the shapes and the location of the surfaces

GOST 2.309—73 ЕСКД. The designation of the roughness of surfaces

GOST 2.310—68 ЕСКД. Drawing on drawings of the symbols in coatings, thermal and other types of processing

GOST 2.311—68 ЕСКД. Picture of thread

GOST 2.312—72 ЕСКД. Symbols and signs of the joints welded joints

GOST 2.313—82 ЕСКД. Symbols and designations of permanent connections

GOST 2.314—68 ЕСКД. Notes on the drawings about the labelling and marking of products

GOST 2.316—68 ЕСКД. Rules applied to the drawings of the inscriptions, technical requirements and tables

GOST 2.317—69 ЕСКД. Axonometric projections

GOST 2.410—68 ЕСКД. Rules for making drawings of metal structures

GOST 2.501—88 ЕСКД. Accounting and storage rules

GOST 21.110—95 СПДС. Specification of equipment, products and materials

GOST 21.113—88 СПДС. Denote the precision of performance

GOST 21.114—95 СПДС. Rules of execution of sketch drawings of General types of non-standard products

GOST 21.203—78 СПДС. Accounting rules and storage of originals of design documentation

GOST 21.501—93 СПДС. Rules for the implementation of architectural and construction working drawings.

APPENDIX 17

HISTORIC TRAIN OPERATION DATA

Date	Train	From Yalama	To Balajari
31.04.2018	3110	23:05	11:00
1/04/2018	3012	1:20	12:20
	3020	2:40	18:00
	3018	6:45	23:45
	3014	9:15	6:05
	3006	13:40	6:30
	3010	17:55	13:35
	3402	18:15	11:05
	3014	23:40	15:10
	3016	1:40	11:45
	2/04/2018	3002	11:40
3004		15:35	1:40
3012		19:10	12:10
3010		23:30	13:30
3402		24:15:00	11:35
3/04/2018	3018	7:05	21:40
	3004	15:40	23:15
	3012	17:50	12:45
	3010	20:00	11:45
	3402	23:20	15:15
4/04/2018	3016	3:35	12:10
	3402	4:35	16:02
	3010	17:50	10:50
	3014	20:15	11:20
6/04/2018	3016	1:50	12:10
	3002	13:00	7/04/2018 6:25
	3004	13:40	23:45
	3010	18:30	7/04/2018 5:05
	3012	20:50	12:00
7/04/2018	3016	24:10:00	13:20
	3402	2:45	16:20
	3018	3:50	18:05
	3002	15:30	22:50
	3008	16:15	13:05
	3012	20:25	8/04/2018 12:40
	3004	23:55	12:05
8/04/2018	9534	2:30	13:55
	3402	13:10	4:55
	3010	16:40	6:55
	3012	19:05	10:50
	3014	22:35	11:35

Date	Train	From Yalama	To Balajari
9/04/2018	3016	3:35	12:35
	3018	7:10	15:25
	3002	10:05	21:55
	3402	14:40	10/04/2018 1:30
	2680	17:15	13:05
	3010	19:10	6:50
	10/04/2018	3016	1:40
3018		3:50	11/04/2018 2:15
3020		7:10	23:20
3002		11:10	3:30
3010		17:45	11/04/2018 12:25
3012		22:45	12:05
3014		23:15	13:40
11/04/2018	3402	3:35	16:05
	3018	4:35	23:20
	3002	5:00	23:50
	3002	11:35	12/04/2018 1:25
	3008	15:00	12:10
	3010	18:15	11:30
	3012	20:05	11:50
12/04/2018	3014	1:55	14:40
	3402	11:55	20:25
	3002	15:45	13/04/2018 3:55
	3010	17:55	6:30
	3014	23:25	10:55
13/04/2018	3018	2:00	18:20
	3402	5:40	8:10
	3020	12:05	21:05
	3010	17:35	14/04/2018 5:55
	3012	19:35	7:10
14/04/2018	3016	2:15	22:55
	3002	12:25	22:40
	3008	16:50	15:04.2018 6:45
	3012	20:00	12:01
15/04/2018	3402	24:40:00	10:50
	3016	2:30	24:40:00
	3006	13:30	16/04/2018 24:55:00
	3010	18:05	5:25
	3012	22:35	11:10

Date	Train	From Yalama	To Balajari
16/04/2018	9536	24:40:00	13:45
	3018	2:30	17/04/2018 24:40:00
	3402	5:00	12:30
	2682	11:30	22:35
	3008	15:20	17/04/2018 4:30
	3402	18:40	6:20
17/04/2018	3014	2:15	18:05
	3002	11:15	23:30
	3004	13:10	18/04/2018 1:35
	3008	16:55	7:15
18/04/2018	3016	24:40:00	18:00
	3002	10:00	24:40:00
	3006	16:00	19/04/2018 2:40
	3010	21:40	11:25
19/04/2018	3016	2:05	16:20
	3402	3:45	16:00
20/04/2018	3012	19:40	20/04/2018 11:25
	3016	2:20	15:50
	3002	8:50	23:05
21/04/2018	3016	24:45:00	12:50
	3012	1:40	12:10
	3402	3:45	16:25
	3002	6:40	18:05
22/04/2018	2686	15:45	22/04/2018 3:05
	3012	19:20	5:35
	3016	1:10	7:30
	3402	1:55	12:05
	3014	4:20	14:10
	3002	9:55	23/04/2018 2:10
23/04/2018	3004	12:50	23:45
	3008	18:05	3:40
	3012	20:00	12:05
	3014	22:55	10:55

Date	Train	From Yalama	To Balajari
23/04/2018	3016	24:10:00	17:55
	3402	4:35	13:55
	3002	11:40	21:40
	2680	18:40	24/04/2018 6:15
	3014	21:05	12:50
	3402	24:15:00	12:05
24/04/2018	3016	24:50:00	14:20
	3018	6:40	22:45
	3008	16:20	25/04/2018 4:35
	3010	19:45	11:10
25/04/2018	3014	24:40:00	6:55
	3016	2:15	13:55
	2680	11:35	23:10
	3006	13:30	26/04/2018 7:05
	3008	17:50	13:00
	3012	1:25	11:05
26/04/2018	3402	4:25	14:30
	2684	5:45	23:50
	3016	10:20	27/04/2018 5:15
	3006	10:45	6:10
	3004	14:20	1:10
	3008	17:40	14:25
	3010	19:40	11:05
	3012	22:50	15:35
	3016	23:15	13:40
	27/04/2018	3402	2:05
3018		10:45	28/04/2018 5:05
3002		14:05	4:50
3008		19:55	12:55
28/04/2018	3006	23:00	12:10
	3012	4:10	19:35
	3402	4:35	10:45
	3002	11:55	23:55
	3008	17:05	29/04/2018 4:25
	3012	19:05	6:10

Date	Train	From Yalama	To Balajari
29/04/2018	3016	5:10	16:55
	3012	18:15	30/04/2018 4:25
	3008	20:00	11:10
30/04/2018	3002	10:15	22:40
	3004	14:10	2:25
	3008	17:35	1/05/2018 6:50
	3012	20:35	11:20

Date	Train	From Balajari	To Yalama
1/04/2018	2301	6:40	13:05
	2401	12:25	17:25
	2403	17:55	24:00:00
	2303	22:40	2/04/2018 4:50
2/04/2018	2401	24:35:00	2/04/2018 6:00
	2301	2:45	14:15
	2421	6:50	12:55
3/04/2018	3401	24:15:00	7:15
	2401	5:15	11:30
	2403	6:30	14:20
	2301	13:45	19:45
	2405	16:25	21:55
	3001	22:15	2:35
4/04/2018	2301	5:00	12:50
	2401	6:00	12:25
	2403	12:55	18:00
	2303	16:30	5/04/2018 24:15:00
5/04/2018	3403	2:25	11:30
	2401	6:45	14:00
	2301	12:50	18:55
	2403	16:35	23:00
6/04/2018	2405	21:30	6/04/2018 4:10
	2301	2:30	8:30
	2143	15:15	21:35
	2401	20:55	7/04/2018 3:05
	2303	21:10	4:05
7/04/2018	2401	24:50:00	8:20
	2301	14:50	19:45
	2401	17:50	8/04/2018 1:35
	2431	22:10	5:10
8/04/2018	2301	2:15	8:20
	2401	9:15	15:25
	2403	12:15	17:40
	2403	18:00	9/04/2018 2:05
	2303	14:00	19:15
	2445	20:55	9/04/2018 6:40
9/04/2018	2449	6:35	12:15
	3403	21:00	10/04/2018 6:25
10/04/2018	2301	5:35	12:20
	2401	6:50	15:10
	2303	14:00	21:50

Çarxı

Date	Train	From Balajari	To Yalama
11/04/2018	2401	24:15:00	7:40
	3401	1:15	8:40
	2301	6:45	12:00
	2303	14:45	20:20
	2403	15:05	21:10
	2405	22:50	4:00
12/04/2018	2301	5:15	13:20
	3403	12:50	18:25
	2401	16:45	22:35
	2403	20:55	13/04/2018 4:30
13/04/2018	3405	23:45	7:50
	2301	13:00	19:50
	2401	20:55	14/04/2018 3:40
14/04/2018	3401	0:50	10:35
	2401	11:35	17:55
	2301	15:20	15/04/2018 1:55
	2403	16:25	3:05
15/04/2018	2415	20:55	5:35
	2625	7:25	13:05
	2301	10:10	17:00
16/04/2018	2401	11:30	17:30
	3403	2:30	10:05
	2419	21:00	17/04/2018 3:20
17/04/2018	2301	22:45	5:00
	2401	3:45	10:35
	2301	14:15	21:25
	2303	16:25	18/04/2018 2:30
	2403	21:35	3:40
18/04/2018	2401	24:55:00	8:00
	2401	5:35	13:10
	2401	11:40	23:10
	2301	12:10	17:30
19/04/2018	3405	12:25	18:55
	2301	6:50	14:25
	2401	9:40	15:55
	2443	14:15	22:35
	2303	21:40	20/04/2018 4:35
20/04/2018	3401	1:20	10:55
	2401	4:10	13:00
	2403	5:00	12:20
	2301	14:00	20:05
	2417	17:55	21/04/2018 24:20:00

Date	Train	From Balaiari	To Yalama	
21/04/2018	2651	2:30	8:55	
	2401	7:25	13:00	
	3403	11:35	23:05	
	2403	12:25	19:05	
	2301	22:25	22/04/2018	4:50
22/04/2018	2401	1:35	7:30	
	3403	4:00	14:40	
	2403	9:20	14:55	
	2445	14:35	20:25	
	2301	16:25	22:45	
23/04/2018	3401	1:25	24/04/2018	7:25
	2401	23:20		5:20
24/04/2018	3401	24:05:00	8:30	
	2301	11:30	17:10	
	2401	13:50	19:35	
25/04/2018	2301	24:20:00	6:35	
	2401	5:55	12:30	
	2303	11:20	17:45	
	2403	16:35	22:30	
	3403	21:50	26/04/2018	5:30
26/04/2018	2429	4:45	11:15	
	2401	6:30	15:55	
	3403	23:25	27/04/2018	7:05
27/04/2018	2401	2:05	8:40	
	2301	6:25	15:10	
	2425	10:20	18:05	
	2403	13:45	20:25	
	2303	16:25	2:20	
	2405	22:40	28/04/2018	4:45
28/04/2018	2301	6:40	14:00	
	2401	14:05	19:30	
	2423	17:55	23:05	
29/04/2018	2301	1:45	7:50	
	2401	2:20	11:20	
	2303	2:45	8:40	
	2403	12:55	19:15	
	2305	14:55	21:40	
	2401	22:00	30/04/2018	5:15
30/04/2018	3401	24:20:00	13:45	
	2401	1:45	7:55	
	2403	4:20	16:00	
	2301	16:25	23:50	

APPENDIX 18

FACILITIES FOR ENGINEER

1. CONSTRUCTION SITE COUMPOUND

- 1.1 All construction site compounds shall be located on a washable hardstanding surface made with either concrete or bituminous surfacing which shall be kept free of mud and dust and washed at regular intervals. All Compounds shall be suitably secured and fenced. The Contractor shall be responsible for providing water, electricity, telephone, sewerage, drainage and all other facilities at each Compound as the Contractor requires to execute the Works. The Contractor shall make all arrangements with and obtain the necessary approvals from the Relevant Authorities for all utility requirements.
- 1.2 The Contractor shall be responsible for adapting any Compound for its own purposes and shall bear all costs involved including costs associated with the provision of utilities and services. Offices, sheds, stores, mess rooms, workshops and other accommodation on the site shall be maintained in a clean and secure condition.
- 1.3 The Contractor shall be responsible for the security of all Compounds, or any part thereof, in its possession and during such times as the Contractor has access to the Compounds. The Contractor shall set up and operate a system whereby only those persons entitled to be in such areas can enter. To this end, the Contractor shall provide specific points at which entry can be affected and where applicable shall provide gates and barriers at such points of entry and maintain at such gates and barriers such security personnel and patrols as may be necessary to maintain security.
- 1.4 The Contractor shall make provision for the accommodation of the Contractor's staff, the Engineer and his Staff, as well as the staff of the subcontracted companies and independent certifiers, etc. in addition to accommodation for representatives of ADY/Employer.
- 1.5 The Contractor shall provide scheme signage at all Compounds in accordance with the requirements of the Local Authorities, National Regulations and Standards, and the Department of Transport and in accordance with all legal signage requirements.

2. EQUIPMENT FOR ENGINEER AND HIS STAFF

2.1 Equipment for office

A schedule of office requisites shall be provided by the Contractor and all items shall be subject to the approval of the Engineer.

On completion of the contract, the instruments and equipment for Engineer and his staff are returned to the Contractor.

2.2 Testing laboratory

The Contractor shall provide and maintain a laboratory and office to be located in the Contractor's plant yard. The said laboratory and offices shall be in a waterproof and heat and cold isolated building of at least 200 m² internal floor area.

The building shall comply with the requirements specified for Housing and Offices.

The laboratory and office is to be used exclusively for design and control testing and it shall be maintained in a clean and tidy fashion to the satisfaction of the Engineer. It shall be connected to the water and electricity supplies. The office shall be provided with all necessary furniture and equipment, stationery, etc. to the satisfaction of the Engineer.

- 2.3 The Contractor shall provide suitable premises, transportation, equipment and staff to ensure the continuing availability of adequate testing facilities throughout the period of performance of the Contract in order to implement the Standards of quality of materials and workmanship required under the terms of the Contract.
- 2.4 The provision of Laboratory facilities to the satisfaction of the Engineer shall be a prerequisite for the beginning of construction operations.
- 2.5 The Contractor shall make provision for the necessary transportation of laboratory personnel, equipment and samples. Any delays to construction operations, or disapproval by the Engineer from the non-execution of prescribed tests due to the Contractor's default in this connection shall be the responsibility of the Contractor.
- 2.6 All samples and records shall be preserved as long as the Engineer may direct, and they shall be kept and labelled in orderly fashion to his satisfaction. The laboratory, its equipment as detailed in the Schedule and all samples and all records shall be open to inspection by the Engineer during all site working hours.
- 2.7 The laboratory shall be staffed by the Contractor with an engineer or engineers well experienced in the testing of soils, concrete and metal.
- 2.8 The Contractor shall submit the name of the manufacturers and a list of laboratory equipment which he intends to provide for the approval of the Engineer.
- 2.9 The Contractor shall perform tests on materials as required and shall supply the Engineer with two copies of the results of each test, such results being entered on a printed form approved by the Engineer.
- 2.10 A third copy of the results of each test shall be retained in the laboratory.
- 2.11 The Contractor shall at all times maintain a sufficient stock of all laboratory glassware, plastic ware, rubber ware etc., to allow for breakages and deterioration. In the event of any of the equipment becoming unusable through any cause, the Contractor will, if required to do so by the Engineer, order replacements to be made.
- 2.12 The Contractor shall give the highest priority to the construction of the laboratory. No permanent work on any section of the Contract shall commence until these items are made available for use unless otherwise agreed by the Engineer. The time schedule for providing the laboratory ready for occupation and use is thus:
- 2.13 Within two (2) months from the Date of the Commencement all facilities for the laboratory, as specified, shall be available and ready for use.
- 2.14 In addition to the general laboratory equipment for measurement, sampling and preparation of samples for test, specialised equipment for routine testing shall be provided by the Contractor and

maintained in good order and adjustment throughout the period of performance of the Contract. The main testing requirements are listed below, but the laboratory shall be equipped to carry out all tests specified in the Contract, and other specialised tests may also be requested by the Engineer if he so considers necessary. The Contractor shall also provide the Engineer a complete set in English (or certified translation where not already published in English) of all material specifications, test standards, design codes, and other documents referred to in the Contract.

2.15 The Contractor shall provide a list of proposed equipment for prior approval of the Engineer. The following test activities shall be carried out:

- Soils
- Classification
- Linear Shrinkage
- Specific gravity
- Compaction (Moisture-density relationship)
- California Bearing Ratio (un-soaked and soaked)
- Field density
- Sulphate content
- Aggregate and Concrete
- Particle size distribution
- Shape characteristics (Elongation and Flakiness)
- Specific gravity
- Bulk density
- Voids
- Absorption
- Organic impurities
- Aggregate Crushing Value
- Consistency of concrete
- Compressive strength (Cement and concrete)
- Initial and final setting times (cement)

3. OFFICES AND ACCOMODATION FOR THE ENGINEER AND HIS STAFF

3.1 The Contractor shall provide, furnish, equip, maintain and service office with facilities for the Engineer and his staff including senior staff, junior staff and technicians, designated ADY's representatives and provide accommodation for the same persons during the contract period to the extent and standards described.

3.2 Office and accommodation shall be made available for the entire duration of the contract. The office and accommodation shall be on rental basis at a location on or near the Site and approved by the

Engineer. The facilities shall be air-conditioned, and temperature controlled to ensure a constant temperature of 20°C +/- 2°C throughout the year. The Contractor shall provide equivalent temporary facilities until the permanent facilities are handed over and approved as complete by the Engineer.

- 3.3 The Contractor, in his tendered rate, shall also allow for all expenses associated with installation and provision of full-time continuous services including high-speed internet access, water (potable/non-potable), electricity (including full-time or stand-by generator if required), sewerage, air conditioning, heating, etc.

4. STAFF

4.1 ENGINEER'S ADMINISTRATIVE AND TECHNICAL STAFF

The Contractor shall be responsible in respect of wages, salaries, insurance, provident fund and all other costs or charges incurred for all staff, including watchmen, chainmen, and cleaners, recruited by the Engineer or the Contractor and employed on the Works, in the office and in the laboratory.

4.2 ASSISTANCE FOR ENGINEER

The Contractor shall provide at all times during the continuance of the Contract all such laboratory and survey assistants, workmen, pegs, tools etc., and transport thereof as the Engineer may require for the carrying out of his duties in connection with the Contract. The instruments and tools shall in any case be provided for the sole use of the Engineer and once supplied shall not be changed or removed without his consent.

5. COMMUNICATION SYSTEM

- 5.1 The Contractor shall provide the Engineer with, for each of the Sites:

- One (1) international direct line for telephone and fax and two (2) national telephone lines;
- A general high-speed (DSL, Wi-Fi, or similar approved) internet system in each room of the Engineer's Office, as part of a local office network/server for centralisation of printers etc., and two other mobile internet accounts for use away from the Engineer's office;
- One (1) new mobile smart phone with GSM provider international contract and 12 new mobile smart phones with GSM provider local contracts.

- 5.2 The Contractor shall allow for all purchasing, rental, servicing, subscription costs and fees. The Contractor shall pay the charge for use of these facilities.

- 5.3 All Smart phones shall be capable of sending and receiving emails and have internet access.

- 5.4 On completion of the Contract, the ownership of mobile phones shall revert to the Contractor.

6. VEHICLES FOR THE SUPERVISION.

- 6.1 The Contractor shall provide the Engineer/Employer with brand new vehicles as detailed below for the exclusive use of the Engineer/Employer and other persons authorised by the Engineer at all times (including times outside the hours being worked on the Contract, and at weekends). These vehicles will be used for all purposes in connection with the Contract.

- 6.2 The Engineer's vehicles shall be licensed and comprehensively insured for use on the public highway by any licensed driver authorised by the Engineer/Employer together with authorised passengers and the carriage of goods and samples. The insurance cover shall extend to liability to third parties arising from accidents involving the vehicles used by the Engineer.
- 6.3 The Contractor shall provide fuel, oil and maintenance (including replacing defective parts, tires, etc., whenever required), arrange the annual legal technical checking in accordance with the Azeri Law, (and obtain the appropriate certificate) and carry out servicing in conformity with the vehicle manufacturer's recommendations. The vehicles shall be provided as soon as practicable after receipt of an appropriate instruction from the Engineer, and shall be fuelled, oiled and maintained as aforesaid until the Taking-Over Certificate is issued, unless released earlier at the direction of the Engineer.
- 6.4 The Contractor shall take care of transport of the vehicles if immobilised and shall be responsible for the repair in the event of breakdown. In case of an accident damaging the vehicle, the Contractor shall be responsible for reinstatement of the vehicle to its original condition.
- 6.5 The Contractor shall be responsible for fuelling of the Engineer's vehicles and shall arrange fuelling so as not to disturb the Engineer's activities. The Contractor shall always maintain a sufficient supply of fuel on site. The fuel supply will be at the Contractor's cost.
- 6.6 The Engineer's vehicles shall be fitted with a fire extinguisher, first aid kit, tow rope, tool kit, wheel wrench, jack and handle, tire pump, spade, torch, double skin steel 20 L fuel can and orange rotating roof lamp with magnetic base. One (1) battery-charging unit shall also be provided for the Engineer's use.
- 6.7 The Contractor shall provide a similar replacement for any of the Engineer's vehicles out of service.
- 6.8 The Contractor shall arrange for and pay all costs, including service and maintenance costs, custom fees, charges, and any other taxes etc. in providing on site and maintaining the Engineer's vehicles.
- 6.9 The vehicles for the Engineer shall be new current models and approved by the Engineer.
- 6.10 The number and type of Engineer's vehicles shall be as follows (per Site – Lot 1 and Lot 2):
- Type I: Two (2) Saloon, Four Wheel Drive, 5-door, long wheel base, Toyota Land-cruiser or similar, diesel engine, minimum engine capacity 4,000cm³;
 - Type II: Five (5) Four Wheel Drive, Double cabin, Pick-up, Toyota Hilux or similar, diesel engine, minimum engine capacity 2,500cm³, with detachable rigid rear cover.
 - Type III: One (1) Sedan, Toyota Corolla or similar with minimum engine capacity 2,000cm³
- 6.11 A total of eight (8) vehicles are to be supplied by the Contractor per Lot.

- 6.12 All vehicles have to be fitted with automatic transmission, power steering, air conditioning, air bags, anti-locking brakes and anti-theft alarms.
- 6.13 The vehicles shall be supplied within four (4) weeks of the Letter of Acceptance or such later time as instructed by the Engineer.
- 6.14 The Contractor shall provide the Engineer, as and when required, with the services of one (1) driver for each of the Engineer's vehicles, including all overtime and accommodation. These drivers shall also carry out general duties as requested by the Engineer.
- 6.15 Up to the end of the contract the vehicles used by the Engineer for the purpose of supervising the works shall be kept in good operating condition to the satisfaction of the Engineer, who may request in case of doubt a specialist car servicing unit at the Contractor's cost. In the event, such certification indicates defaults, the Contractor shall make good to the car defaults out of his own resources until the certification is secured.
- 6.16 After completion of the Contract, the vehicles will be returned to the Contractor.

7. SURVEY EQUIPMENT FOR THE ENGINEER'S USE

- 12.1 The Contractor shall provide the survey equipment required by the Engineer. The equipment shall comprise new self-registering theodolite and electro-optical distance measuring instruments (total station) and automatic levelling instrument plus required accessories (tripods, staff, reflectors, etc.) and software.
- 12.2 Survey assistants shall be provided by the Contractor.
- 12.3 On completion of the Contract the survey equipment shall be returned to the Contractor.

8. PROTECTIVE CLOTHING

- 8.1 The Contractor shall supply the following items of protective clothing for the Engineer's supervisory staff, for each one of the Sites:
- 14 safety helmets,
 - 14 Reflectorized Safety Vests (colour to be advised)
 - 12 sets of waterproof clothing,
 - 12 sets of heavy jackets with removable lining and reflectorized vest,
 - 12 pairs steel toe capped boots,
 - 5 sets safety gloves,
 - 5 protective glasses (spectacles),
 - Ear mufflers and face masks as required.

APPENDIX 19

CERTIFICATES

FORM OF TAKING-OVER CERTIFICATE

Contract: [. . . .insert name of contract and contract identification details. . . .]

Date:

Certificate No.:

To: [. . . .insert name and address of Contractor. . . .]

Dear Sir and/or Madam,

Pursuant to Sub-Clause 10.1 (Taking-Over of the Works and Sections) of the General Conditions of the Contract entered into between yourselves and the Employer dated [. . . .insert date. . . .], relating to the [. . . .brief description of the Facilities], we hereby notify you that the following Section(s) of the Works was (were) complete on the date specified below, and that, in accordance with the terms of the Contract, the Employer hereby takes over the said Section(s) of the Works.

1. Description of the Section(s): [. . . .description]
2. Date of Completion: [. . . .date]

However, in accordance with Sub-Clause 10.1(a), you are required to complete the minor outstanding work and remedy the defects listed in the attachment hereto as soon as practicable.

This letter does not relieve you of your obligation to complete the execution of the Works in accordance with the Contract nor of your obligations during the Defects Notification Period.

Yours faithfully,

[. . . .Signature]

Engineer to the Contract

FORM OF PERFORMANCE CERTIFICATE

Contract: [. . . .insert name of contract and contract identification details. . . .]

Date:

Certificate No.:

To: [. . . .insert name and address of Contractor. . . .]

Pursuant to Sub-Clause 11.9 (Performance Certificate) of the General Conditions of the Contract entered into between yourselves and the Employer dated [. . .date. . .], relating to the [. . .brief description of the Works. . .], we hereby notify you that your obligations under the Contract with respect to the following Section(s) of the Works were satisfactorily completed on the date specified below.

1. Description of the Section(s): [. . . description . . .]
2. Date of completion of obligations: [. . . date . . .]

Yours faithfully,

[. . . .Signature]

Engineer to the Contract

APPENDIX 20

BRIDGES & STRUCTURES

20 BRIDGES & CULVERTS

20.1.1 In Lot 1, between SUMGAYIT and GIL-GIL-CHAY Stations, the structures are composed of as per Table 20: Details of Bridges and Culverts are set out in **Attachment 3** and Attachment 4 respectively.

TABLE 20 - Lot 1 Bridges & Culverts

SPAN	Length	Bridges								Culvert				
		less 25 m				more 25 m				Grand Total	Cap.rep	Repair	Replace	Grand Total
		Cap.rep	Repair	Replace	Nil Work	Cap.rep	Repair	Replace	Nil Work					
1. Sumqayıt baş - H.Z.Tağıyev	10			7		2				9	2	2	2	6
left				4		1				5	1	1	1	3
right				3		1				4	1	1	1	3
2. H.Z.Tağıyev - H.Z.Tağıyev çe	7									0		4	8	12
left										0		2	4	6
right										0		2	4	6
3. H.Z.Tağıyev çeş. - Yaşma	4			4						4			2	2
left				2						2			1	1
right				2						2			1	1
4. Yaşma - Sitalçay	10					1		1		2			6	6
left								1		1			3	3
right						1				1			3	3
5. Sitalçay - Giləzi	11	1		3		2	1			7	2		10	12
left		1		2		1				4	1		5	6
right				1		1	1			3	1		5	6
6. Giləzi - Zarat	10			3						3			10	10
left				2						2			5	5
right				1						1			5	5
7. Zarat - Siyəzən	9	2		2						4			10	10
left		1		1						2			5	5
right		1		1						2			5	5
8. Siyəzən - Qızılburun	11	4		2				2		8			12	12
left		2		1				1		4			6	6
right		2		1				1		4			6	6
9. Qızılburun - Gil-Gilçay	10			6		2		2		10		2	25	27
left				2				2		4		1	12	13
right				4		2				6		1	13	14
Total for LOT1	82	7	0	27	0	7	1	5	0	47	4	8	85	97

20.1.2 Steel Bridges with Concrete Abutment & Concrete Deck

Steel bridges with concrete abutment on LOT 1 between Sumgayit and Gil-Gil-Chay stations. All these bridges are to be designed or rehabilitated to have a concrete deck and ballasted track with a minimum 350mm of ballast under the sleeper. Repair and replacement works are required for these bridges and shall be confirmed by the Contractor in the Definitive Design & Drawings.

20.1.3 Reinforced concrete bridges:

The following types of concrete bridges can be found existing:

- Bridges that have a deck with good appearance and does not need a significant rehabilitation work except some cleaning and surface repair.
- Bridges that have a deck with local damages, cracks, bursting-spalling concrete and reinforcement corrosion.
- Bridges that have a deck with significant damaged parts and need to be replaced by similar structures.
- All bridges are to be designed or rehabilitated to have a concrete deck and ballasted track with a minimum 350mm of ballast under the sleeper.

20.1.4 Requirements for Rehabilitation, Repair & Replacement Work – Bridges & Culverts

The Employer has undertaken an initial condition assessment of bridges and culverts and details are available in Attachments 3 & 4 for the Contractor's reference. Many aspects of the work identified in the Employer's condition reports shall be assessed for implementation by the Contractor. The Contractor's own investigations and the Contractor's design and work activities for the remediation and replacement works for bridges and culverts shall be required as shall be the inclusion of the following guidelines, references and requirements:

- i. The Contractor shall follow the guidelines set out in UIC Leaflet 171 "*Guidelines for Railway Bridges*" when assessing and determining load capacity and design requirements.
- ii. Masonry arch bridges shall be assessed taking into account and following the actions in accordance with EN 1991-2 (UIC Leaflet 776-1R):
- iii. Specific and for each location, the Contractor's Definitive Design and Drawings for the remediation, repair and replacement work for bridges and culverts, including all temporary works proposed, shall be presented and approved before site work begins.
- iv. All bridges and culverts shall be designed or rehabilitated to carry a ballasted track with a minimum 350mm of ballast under the sleeper.
- v. Where the Employer's initial condition assessment considers or recommends replacement of the structure with another structure, the Contractor shall further assess this need. The Contractor shall undertake the assessment, design and construction based on the Contractor's own assessments and findings, and submit these through the three-step design requirements (see **Appendix 24**) for acceptance.
- vi. The rehabilitation and replacement works include any other works the designer specifies for the structure to achieve its design life as set out in Part 2, Clause 7 of this document. Such works shall be documented and set out in the design details and shall be included in the Definitive Design and Drawings.
- vii. All bridge and culvert design and construction shall comply with local Azerbaijan standards, SNIP 2.05.03-84, UIC 776-1R and UIC 776-2R.
- viii. Where bridges are to be designed and reconstructed/renewed in concrete, all elements of the superstructure shall be pre-cast concrete, and pre-cast pre-stressed concrete. No in-situ concrete work for superstructure elements (except minor works such stitch joints, pre-cast deck waterproofing, and aprons etc.,) shall be undertaken on bridges or culverts due to programme constraints.
- ix. Specific design, geotechnical investigation, assessments and site works may be required to determine the strength and load capability of a structure or an element of a structure to permit the 25 tonne axle load and 150km/hr design speed specified. The approaches set out in UIC 778 4R (2009) shall be followed for the investigations and assessment. There may be a need to strengthen any element of the bridge or culvert, the foundation for bridge abutments and piers, especially for those that are unstable or show signs of settling, or may settle due to the track loading in the future. Such details shall be documented, designed in compliance with SNIP 2.05.03-84, UIC 171, UIC 776-1R and UIC 776-2R, and shall be included in the Definitive Design and Drawings.
- x. There are multiple masonry arch bridges on both main lines, especially on the Right track. These masonry arch bridges were generally constructed over 100 years ago. In accordance

with UIC 778-3 (2011) and EN 1996, the Contractor is required to inspect, assess, scope, design and have approved as a Definitive Design & Drawings prior to undertaking the repair and strengthening works required to ensure these structures will have the required design life as set out in Part 2, Clause 7 of this document.

- xi. Additional works for the strengthening and/or repairing of the bridge abutments, arch/piers, columns, slope protection and bridge foundations shall be incorporated into the design for each bridge’s rehabilitation, to ensure the nominated design life is met, and shall be included in the Definitive Design and Drawings.
- xii. All bridge replacements, new box culverts and new pipe culverts shall have designed and installed a headwall, wing wall and apron at each end. All aprons shall have a curtain (cut-off) wall of minimum depth 600mm. See typical reference details below in Figure 20.1 20.2, and 20.3.
- xiii. All box culverts shall be four sided box culverts designed specifically for railway loading. See typical example in Figure 20.4 & 20.5. Three sided culverts shall be permitted only for protection of existing utilities.
- xiv. All bridges and culverts (existing and replacements), shall have installed a ballast wall to prevent ballast falling from the track. The ballast wall shall be capable of resisting a lateral load of 50kN applied at the top of the wall without permanent displacement. The top of the ballast wall shall be set 200mm below ToR, and a minimum of 1850mm from nearest track centreline. Bridges and culverts with edges further than 3100mm from nearest track centreline need not have a ballast wall.
- xv. Remedial and repair works for bridges and culverts shall comply with the guidelines from AASHTO (IGSRB-1, Maintenance & Repair Guidelines) and BS EN 1504. The works shall be documented, designed and included in the Definitive Design & Drawings for approval. Typical replacement, remedial and repair works include but are not limited to:
 - Spalled and damaged concrete;
 - Spandrel face repair, including repointing for masonry structures;
 - Exposed reinforcement bars;
 - Cracked concrete elements;
 - Damaged, spalling and aged bridge decks;
 - All bridge bearings and bearing pads with Employer Condition 2 to 5;
 - Damaged, blocked or corroded drainage pipes;
 - Guard rails on the track;
 - Approach slabs with Employer Condition 2 to 4;
 - Handrails with Employer Condition 2 to 4;
 - Slope protection to repair and prevent erosion and slips.
- xvi. Where soil or embankment erosion due to drainage is problematic or could be problematic, it is required in the design to provide rock gabion walls or other means to protect the embankment, foundations and the waterway from erosion. Individual gabions shall be minimum of 900mm thick and a maximum of 2000mm high.

- xvii. Waterways for all culverts and bridges of all types shall have the waterway cleared of silt and debris, the waterway embankments defined, embankment and slope protection works undertaken, and the source stream trained to pass through the cleaned waterway.

Figure 20.1 Typical Culvert End Arrangements – All Pipe Culverts

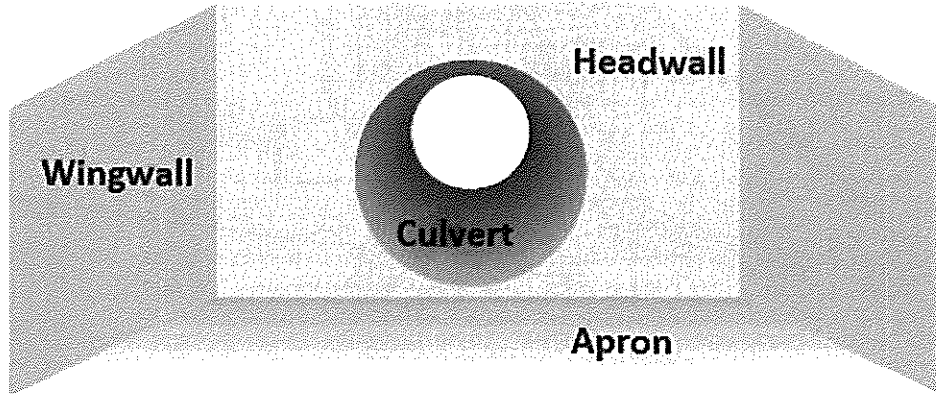

Figure 20.2 Typical Culvert End Arrangements – Pipe Culverts

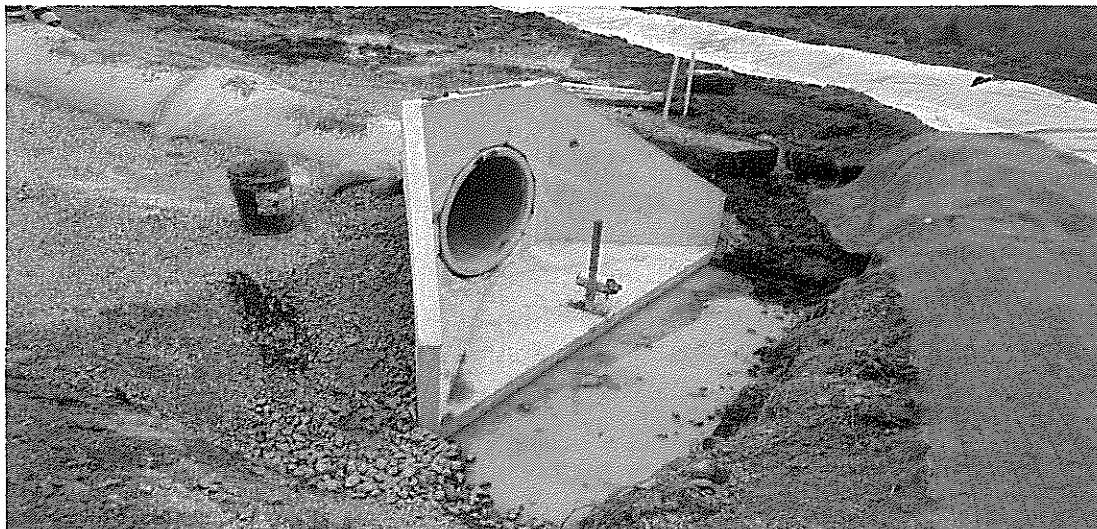

Figure 20.3 Typical Culvert End Arrangements – All Box Culverts

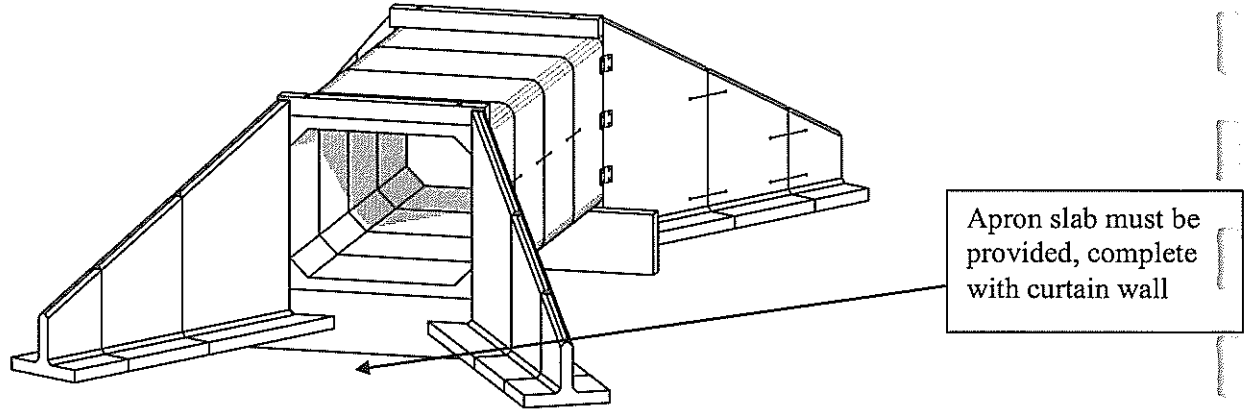
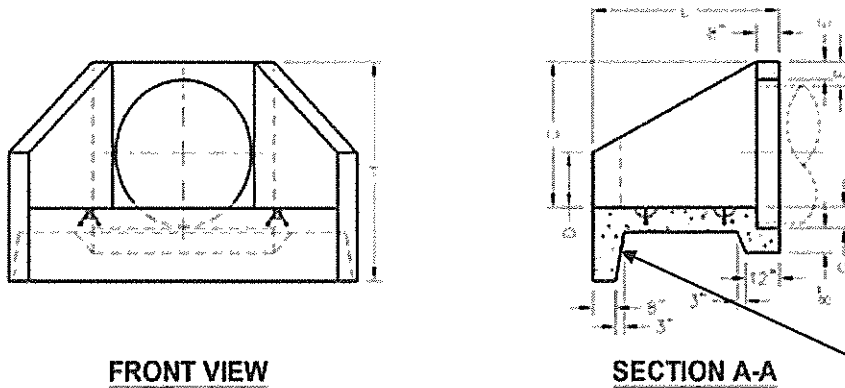

Figure 20.4 Reference Dimensions for Wing Walls, Headwall & Apron



Apron curtain wall minimum depth 600mm

PIPE SIZE	HOLE SIZE	"W"	"L"	"H"	"A"	"B"	"C"	"D"	"E"	"F"	"G"	WT.
30" RCP	40"	110"	60"	72"	64"	50"	48"	18"	13"	143"	5"	9615 Lbs.
36" RCP	48"								6"	8"	6"	
42" RCP	54"	146"	74"	87"	80"	70"	63"	27"	10"	161"	6"	15,065 Lbs.
48" RCP	62"								8"	8"	7"	
54" RCP	70"											
60" RCP	76"	172"	88"	98"	89"	80"	74"	33"	6"	9"	8"	20,428 Lbs.

Hole Size For All Other Pipe Types Will Be Pipe O.D.+ 2"-4"

Figure 20.5 – Typical Four Sided Box Culvert

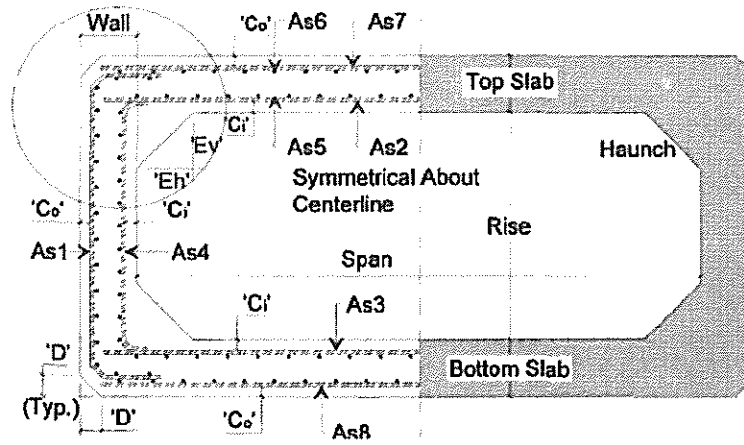
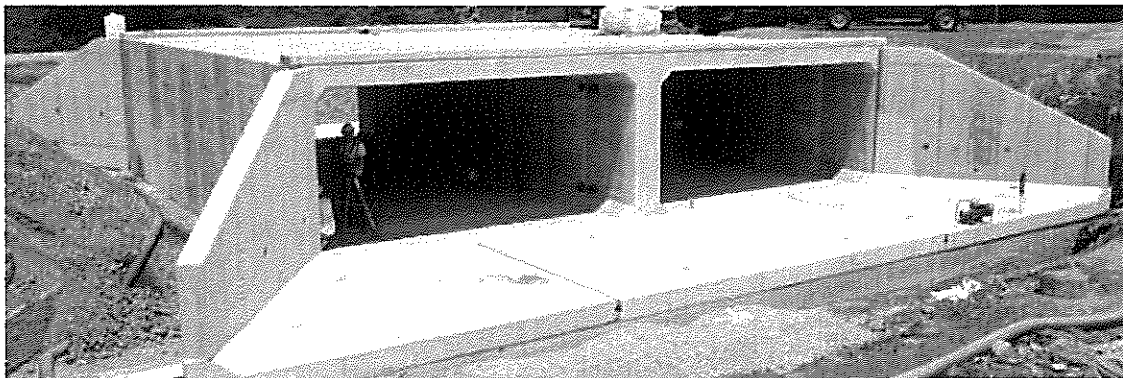

Figure 20.6 – Typical Dual Cell Box Culvert with Wing Wall and Apron



NOTE:

The tables set out on the following pages provides some further details of the bridges and structures included in the Lot 1 Contract:

20.2 LOT 1 BRIDGE DETAILS

LOT 1 - Between SUMGAIT and GIL-GIL-CHAY Stations, the structures are composed of:

There are 47 bridges in LOT1 : 34 bridges (L<25m); 13 bridges (L>25m);

- Reinforced concrete bridge: 31 bridges (L<25m); 6 bridges (L>25m);
- Bridge with rock spans: 3 bridges (L<25m); 6 bridges (L>25m);
- Mixed type bridge: 1 bridges (L>25m);

There are:

- 9 Bridge need to be replaced with pipe: 9 bridges (L<25m);
- 11 Bridge need to be replaced with box curvert; 11 bridges (L<25m)
- 10 Bridges have deck with significant damaged parts and need to be replaced by similar structures : 6 bridges (L<25m); 4 bridges (L>25m);
- 14 Bridges have deck with local damages, cracks, bursting- spalling concrete and reinforcement corrosion (capital repair): 7 bridges (L<25m); 7 bridges (L>25m);
- 1 Bridge have a deck with good appearance and does not need significant rehabilitation work except some cleaning and surface repair (current repair): 1 bridges (L>25m);
- 1 Bridge supports must be kept and the beams of the bridge must be replaced: 1 bridges (L>25m);
- 1 Bridge beams must be replaced and the supports must be repaired: 1 bridges (L<25m);

Table 20.2 below sets out bridge details in abbreviated form. For more details see Attachment 3 – Bridge Details

TABLE 20.2 – LOT 1 BRIDGE DETAILS

N	Chainage (km+ m)	Track No. or Station	Line Section	Bridge Type	No. of spans & length (m)	Total Bridge Length (m)	Height of bridge (m)
1	2620+900	station	Guzdak-Sumqayit	RC	1x5	15.87	6.25
2	2619+340	left	Sumqayit-H.Z.Tagiyev	RC	1x6.3	18.8	2.98
		right	H.Z.Tagiyev-Sumqayit	RC	1x7.7	19.2	6.32
3	2619+136	right	H.Z.Tagiyev-Sumqayit	Masonry Arch	1x23.22	54.74	14.36
		left	Sumqayit-H.Z.Tagiyev	Mixed type	1x10.8+1x23.92+1x10.8	55.36	14.75
4	2610+900	left	Sumqayit-H.Z.Tagiyev	RC	1x5.3	11.76	5.28
		right	H.Z.Tagiyev-Sumqayit	RC	1x4.8	13.27	5.36
5	2610+300	left	Sumqayit-H.Z.Tagiyev	Masonry Arch	1x4.6	13.2	3.84
		right	H.Z.Tagiyev-Sumqayit	Masonry Arch	1x4.86	11.14	2.95

N	Chainage (km+ m)	Track No. or Station	Line Section	Bridge Type	No. of spans & length (m)	Total Bridge Length (m)	Height of bridge (m)
6	2602+658	left	Tagiyev- Yashma	RC	1x4.8	12	3.84
		right	Yashma- Tagiyev	RC	1x4.87	12.09	3.05
7	2600+029	left	Tagiyev- Yashma	RC	1x11.4	23.3	4.9
		right	Yashma- Tagiyev	RC	1x11.23	23.3	4.17
8	2594+370	left	Yashma- Sitalchay	Mason ry Arch	5x5.5	37.9	5.85
		right	Sitalchay- Yashma	RC	5x5.46	38.23	4.57
9	2587+397	left	Sitalchay- Gilazi	RC	2x4.7	15.87	3.97
		right	Gilazi- Sitalchay	RC	2x4.92	16.56	2.9
10	2586+713	station	Sitalchay- Gilazi	RC	2x4.35	15.87	3.3
11	2581+344	left	Sitalchay- Gilazi	RC	1x11.4	23.35	6.14
		right	Gilazi- Sitalchay	Mason ry Arch	1x11.4	28.6	6.23
12	2580+541	right	Sitalchay- Gilazi	Mason ry Arch	1x14	32.6	6.7
		left	Gilazi-Sitalchay	RC	1x13.9	28.82	1.87
13	2576+600	station	Gilazi-Zarat	RC	2x5	22.7	1.67
14	2573+153	left	Gilazi-Zarat	RC	2x7.1	20.17	3.02
		right	Zarat-Gilazi	RC	2x7.6	20.8	2.69
15	2564+551	left	Zarat-Siyazan	RC	1x4.7	11.3	3.58
		right	Siyazan-Zarat	RC	1x4.82	11	3.3
16	2560+937	left	Zarat-Siyazan	RC	2x7.1	21.53	3.76
		right	Siyazan-Zarat	RC	2x7.23	21.28	3.65
17	2557+901	left	Siyazan- Qizilburun	RC	2x7.23	20.6	2.96
		right	Qizilburun- Siyazan	RC	2x7.8	20.79	4.22

N	Chainage (km+ m)	Track No. or Station	Line Section	Bridge Type	No. of spans & length (m)	Total Bridge Length (m)	Height of bridge (m)
18	2557+280	left	Siyazan- Qizilburun	RC	2x7.25	21.45	4.33
		right	Qizilburun- Siyazan	RC	2x7.23	20.6	2.5
19	2553+320	left	Siyazan- Qizilburun	RC	1x2.55	8.36	2.16
		right	Qizilburun- Siyazan	RC	1x2.55	8.28	2.15
20	2550+371	left	Siyazan- Qizilburun	RC	3x11.27	53.8	7.8
		right	Qizilburun- Siyazan	Masonry Arch	3x11.6	55.56	9.8
21	2546+631	station	Qizilburun- Gilgilchay	RC	1x8.67	18.67	4.46
22	2545+559	left	Qizilburun- Gilgilchay	RC	2x6.7	22.19	3.89
		right	Gilgilchay- Qizilburun	RC	2x7.23	21.59	3.58
23	2543+844	left	Qizilburun- Gilgilchay	RC	1x4.6	12.76	2.87
		right	Gilgilchay- Qizilburun	RC	1x5.77	16.55	3.93
24	2541+651	left	Qizilburun- Gilgilchay	RC	3x11.5	44.08	4.37
		right	Gilgilchay- Qizilburun	Masonry Arch	6x5.07	45.5	4.16
25	2539+738	right	Gilgilchay- Qizilburun	Masonry Arch	1x7.1	19.3	7
26	2538+514	left	Qizilburun- Gilgilchay	RC	5x11.5	70.34	5.32
		right	Gilgilchay- Qizilburun	RC	5x11.5	73.2	7

20.3 LOT 1 CULVERT DETAILS

LOT 1 - Culverts

There are 54 pipes, cross-track ditches and siphons in the Sumgayit – Gil Gil chay section:

- open cross-track ditches 13 pcs (L<25m);
 - closed cross-ditches 4 pcs (L<25m); 4 pcs (L>25m);
 - reinforced-concrete pipes: 12 pcs (L<25m); 4 pcs (L>25m);
 - reinforced-concrete cross-ditches: 8 pcs (L<25m);
 - stone pipes 7 pcs (L<25m);
 - siphon: 1 pcs (L<25m); 1 pcs (L>25m);
-
- pipes: 19 pcs (L<25m); 4 pcs (L>25m);
 - 29 culverts: 25 pcs (L<25m); 4 pcs (L>25m);
 - siphons: 1 piece (L<25m); 1 siphon (L>25m);

Out of 23 pipes, 13 pipes are required to be replaced with new reinforced-concrete pipe culvert.

12 pcs (L<25m); 1 pcs (L>25m);

3 pipes (L>25m) are required to be replaced with new reinforced-concrete box culvert.

4 pipes are required to be repaired. (L<25m);

3 pipes are required to be heavily repaired. 3 pcs (L<25m);

Out of 29 closed, open and reinforced-concrete cross-track ditches, 28 No. are required to be replaced with new a reinforced-concrete pipe. 24 pcs (L<25m); 4 pcs (L>25m);

1 piece is advised to be repaired. 1 pcs (L<25m);

Out of 2 siphons, 2 siphons are advised to be replaced with new siphon. 1 pcs (L<25m); 1 pcs (L>25m);

Table 20.3 below sets out culvert details in abbreviated form. For more details see Attachment 4 – Culvert Details.

TABLE 20.3 – LOT 1 CULVERT DETAILS

N	Chainage (Km + m)	Track No. or Station	Line Section	Culvert Type	Culvert Size/Dia (m)	Culvert Length (m)
1	2619+740	R/L	Sumqayıt st.	RC pipe	1,5	32,2
2	2616+540	R/L	Sumqayıt-H.Z.Tağıyev	RC pipe	0,85	11,0
3	2614+750	R/L	Sumqayıt-H.Z.Tağıyev	RC pipe	1,0	12,0
4	2609+500	R/L+ 4 track	St. H.Z.Tağıyev	RC culvert	1,10	16,6
5	2608+441	R/L	H.Z.Tağıyev-Tağıyev çeş.	Stone & Pipe	4,25	18,0
6	2607+735	left	H.Z.Tağıyev-Tağıyev çeş.	Stone & pipe	1,5	7,65

N	Chainage (Km + m)	Track No. or Station	Line Section	Culvert Type	Culvert Size/Dia (m)	Culvert Length (m)
		right	H.Z.Tağiyev-Tağiyev çeş.	RC pipe	1,10	7,65
7	2606+836	right	H.Z.Tağiyev-Tağiyev çeş.	RC culvert	1x1,0	7,50
7	2606+836	left	H.Z.Tağiyev-Tağiyev çeş.	Stone & Pipe	1,4	7,55
8	2604+650	R/L	H.Z.Tağiyev-Tağiyev çeş.	open culvert	2x0,5	12,0
9	2603+650	R/L	H.Z.Tağiyev-Tağiyev çeş.	RC pipe	0,85	11,61
10	2601+810	R/L	Tağiyev çeş.-Yaşma	RC pipe	1,0	11,92
11	2592+138	R/L	Yaşma-Sitalçay	RC pipe	0,85	13,0
12	2590+155	R/L	Yaşma-Sitalçay	RC pipe	0,85	13,0
13	2589+087	R/L	St. Sitalçay	RC pipe	0,85	19,47
14	2584+790	R/L	Sitalçay-Giləzi	RC culvert	0,85	11,5
15	2581+995	right	Sitalçay-Giləzi	Stone & Pipe	2,13	9,5
15	2581+995	left	Sitalçay-Giləzi	RC pipe	1,46	6,0
16	2580+050	R/L	Sitalçay-Giləzi	RC culvert	0,8	10,0
17	2579+364	R/L	Sitalçay-Giləzi	RC culvert	2x0,5	10,0
18	2579+050	R/L	Sitalçay-Giləzi	RC culvert	1,0	10,0
19	2578+577	R/L	St. Giləzi	RC culvert	1,0	23,1
20	2576+745	R/L	Giləzi-Zarat	RC culvert	0,5	9,0
21	2575+180	R/L	Giləzi-Zarat	RC culvert	0,75	11,30
22	2571+386	R/L	Giləzi-Zarat	open culvert	0,51	11,46
23	2570+275	R/L	Giləzi-Zarat	RC pipe	2x2,20	36,45
24	2569+236	R/L + 2 tracks	Zarat st.	closed culvert	0,85	25,73
25	2566+725	R/L	Zarat-Siyəzən	RC pipe	2x2,2	36,45

N	Chainage (Km + m)	Track No. or Station	Line Section	Culvert Type	Culvert Size/Dia (m)	Culvert Length (m)
26	2565+618	R/L	Zarat-Siyəzən	open culvert	0,50	12,03
27	2565+271	R/L	Zarat-Siyəzən	open culvert	0,50	11,29
28	2562+052	R/L	Zarat-Siyəzən	closed culvert	0,85	11,61
29	2561+546	R/L	Zarat-Siyəzən	open culvert	0,50	12,91
30	2554+824	R/L	Siyəzən-Qızılburun	RC pipe	2x2,20	77,80
31	2553+727	R/L	Siyəzən-Qızılburun	Stone & Pipe	0,85	11,85
32	2552+078	R/L	Siyəzən-Qızılburun	Stone & Pipe	0,7/0,85	10,60
33	2550+918	R/L	Siyəzən-Qızılburun	siphon	0,53	27,70
34	2549+351	R/L	Siyəzən-Qızılburun	siphon	0,53	24,80
35	2548+287	R/L+ 4 track	Qızılburun st.	closed culvert	0,50/0,53	37,54
36	2547+828	R/L+ 4 track	Qızılburun st.	closed culvert	0,5	32,07
37	2547+463	right+ 3 track	Qızılburun st.	Stone & Pipe	0,57	23,52
37	2547+463	1 track	Qızılburun st.	closed culvert	0,85	8,50
38	2544+716	R/L	Qızılburun-Gilgilçay	open culvert	0,53	10,22
39	2543+975	R/L	Qızılburun-Gilgilçay	open culvert	0,5	11,90
40	2543+859	R/L	Qızılburun-Gilgilçay	open culvert	0,5	11,66
41	2543+056	R/L	Qızılburun-Gilgilçay	open culvert	0,5	12,10
42	2542+780	R/L	Qızılburun-Gilgilçay	open culvert	0,5	11,90
43	2542+637	R/L	Qızılburun-Gilgilçay	open culvert	0,75	11,92
44	2542+112	R/L	Qızılburun-Gilgilçay	open culvert	0,5	12,90
45	2541+088	R/L	Qızılburun-Gilgilçay	closed culvert	0,85	11,84
46	2539+951	R/L	Qızılburun-Gilgilçay	closed culvert	0,85	12,03

N	Chainage (Km + m)	Track No. or Station	Line Section	Culvert Type	Culvert Size/Dia (m)	Culvert Length (m)
47	2539+738	left	Qızılburun-Gilgilçay	RC pipe	6	12,42
48	2539+618	R/L	Qızılburun-Gilgilçay	RC pipe	0,85	13,42
49	2538+115	right+ 3 track	Qızılburun-Gilgilçay	closed culvert	0,85	29,45
50	2538+115	left	Qızılburun-Gilgilçay	open culvert	0,75	8,60

APPENDIX 21

PERSONNEL REQUIREMENTS

Personnel Requirements

Using Form PER - 1 and PER - 2 in Section 4 (Bidding Forms), the Bidder must demonstrate that it has personnel who meet the following requirements:

No.	Position	Total Work Experience [years]	Experience in Similar Work [years]
1	Project Manager	20	10
2	Deputy Project Manager	15	5
3	Railway Track Design Engineer	15	10
4	Railway Bridge & Structures Engineer	15	10
5	Railway Construction Engineer	15	10
6	Design Manager	15	10
7	Design Coordination and Expediting Manager	20	10
8	Quality Control Manager	15	5
9	Health & Safety Manager	15	5
10	Environmental & Social Safeguards Specialist	10	5

APPENDIX 22

EQUIPMENT REQUIREMENTS

Equipment

Using Form EQU in Section 4 (Bidding Forms), the Bidder must demonstrate that it has access to the key equipment listed below. Track bound equipment shall be 1520mm gauge compatible:

No.	Equipment Type and Characteristics	Minimum No. Required
1	Track Renewal and Track Laying Machine	1
2	Long rail transport unit with unloading equipment	1
3	Heavy Tamping Machine for Track	2
4	Heavy Tamping Machine for Turnouts	1
5	Stabilisation and Consolidation Equipment (DTS)	2
6	Fixed Flash-Butt Welding Machine	1
7	Mobile Flash-Butt Welding Machine Set*	2
8	Ballast Regulator	2
9	Ballast Cleaner	1
10	Rail Grinder	1
11	Crushing and Grading Plant	2
12	Mobile Crane – 50T	1

*Transfer of Ownership of Mobile Flash-Butt Welder Machine Set

Two (2) mobile flash-butt welding machines shall transfer to the ownership of the Employer within three (3) months after commencement of the Defect Notification Period.

Both mobile flash-butt welder sets shall be fully reconditioned by the manufacturer before handover. The mobile flash-butt welder set shall consist, as a minimum, of:

- i. Welder
- ii. Control Cabinet
- iii. Power system
- iv. Pump station
- v. Water cooling plant
- vi. Electric connectors
- vii. Hydraulic connectors
- viii. Mobile diesel-generator plant
- ix. Transport vehicle
- x. Spares as recommended by Manufacturer

Appendix 23

TRACK SIGNAGE REQUIREMENTS

1. INTRODUCTION

The Contractor shall prepare the specification, design, supply, and undertake the installation for Track Signage Requirements as detailed in Appendix 23 for this Lot 1 Contract, Sumgayit to Gil-Gil-Chay.

2. KILOMETRE POSTS & TRACK MARKERS

- 2.1 Starting from Sumgayit Station at km 2621 km to Gil-Gil-Chay station at km 2538,200, the requirement is to precisely determine the coordinates for the installation/reinstallation point for the kilometre and main posts.
- 2.1 The kilometre posts are installed on the right-hand side by counting kilometres through expansion of the clearance on the curved tracks and ease curves within 3400mm from the centre line of the edge track; in the rabbets and their outlets (at length 100m) at a distance not less than 5700mm from the centre line of the edge track.
- 2.2 The 100m markers are installed between the kilometre posts every 100m.
- 2.3 The production and installation of the markers at the start and the end of the transitions and curves.
- 2.4 The permanent reference stakes for curves of each track are installed on the right and left side of the track within 2000mm of the actual location of the point referred to, as below. The letters marked on the stakes shall be as follows:
 - o TSS – end of tangent track and start of spiral transition curve.
 - o LS – Length of spiral (to be located within 2000mm of start of spiral).
 - o SCS – end of spiral transition curve and start of constant radius curve;
 - o CSS – end of constant radius curve and start of spiral transition curve,
 - o PK – number of previous post plus distance from it to start (end) of curve (in m.),
 - o R – Radius of curve (to be located within 200mm from crown of curve),
 - o C – Cant of the rail, with a stake located at the beginning of cant and the location where cant is at its maximum.
- 2.5 The reference stakes may be made from concrete or hewn stone, and shall have a 300mm long galvanised steel spike protruding from the base of the stake then firmly embedded into the sub-ballast such that the stake is not moveable.
- 2.6 Permanent stakes for both rail lines shall be provided and installed including determination of their coordinates and the exact height (altitude) and connection with the State network.
- 2.7 All existing posts and markers, and reference stakes etc. shall be replaced.
- 2.8 Prior to the installation, at least 30 days should be passed from preliminary surveying for the setting of the points to allow for settlement. At the installation time, each point shall have two (2) GPS measurements taken at min. 2-hour interval, each measurement should last period of time agreed with the Engineer to provide the required accuracy.

- 2.9 The height (altitude) of the points should be determined by connecting to the State vertical control survey network with maximum error of 1.5mm/1km. That kind of error may be reached only by precise levelling.
- 2.2 Denotation of the kilometres, posts and metres along the entire Sumgayit to Gil-Gil-Chay for Lot 1 should be fixed in the engineering design as per the standard of the Azerbaijan Railways CJSC.

3. PERMANENT TRACK SURVEY MARKERS

- 3.1 For the maintenance of the track, details of the track location (Offset, height, cant) are required at very regular locations for each track. These details are required by tamping machines and others who are ensuring the track is correctly located during maintenance.
- 3.2 The height (altitude) of the points should be determined by connecting to the State vertical control survey network with maximum error of 1.5mm/1km. That kind of error may be reached only by precise levelling.
- 3.3 Spatial position of the track is determined by boundary markers (hereafter called "Survey Bolts"). The distance of the designed centre line, the height of the designed track line, the track cant, is determined from each Survey Bolt by design documentation (engineering design) as per the guidelines of this document.
- 3.4 The main trunk routes on the sections Sumgayit – Gil-Gil-Chay shall be identified by those Survey Bolts accurately and permanently placed in all new poles of the overhead system, for each track. Note that this interface shall be required with the OCS contractor.
- 3.5 The geodetic surveying of the location and height of the Survey Bolts shall be extended from the nearest points of the national survey mark located outside the Site. Permanent stakes shall be established from those national markers and benchmarks onto a permanent marker designed by the Contractor for the local railway network (within ADY RoW) from which can be plotted the setting out for all Survey Bolts. Permanent Track Survey Markers within ADY shall be located at intervals not exceeding two (2) kilometres.
- 3.6 Survey Bolts should provide uniqueness and precision of the parameters of the track's spatial position. At geodetic surveying of the location and height of the Survey Bolts it should be extended from the nearest stakes of the local (railway) network.
- 3.7 Survey Bolts are the basis for construction, acceptance, inspection and maintenance of the track's spatial position during operations. The manager of the relevant section which has Survey Bolts on it must keep the documentation including the data of tracks geometry regarding Survey Bolts (engineering design).
- 3.8 Survey Bolts production. Survey Bolts are steel cylindrical elements of D16mm for welding, building up or wrapping onto a shooting nail with the internal thread. Length of Survey Bolts for fixing steel structures is 30mm; concrete and other structures is approx. 50mm.
- 3.9 Survey Bolts fitting on OCS supports. A Survey Bolt of L50mm is fitted onto a shooting nail or stuck into a drilled hole of D14mm.

- 3.10 Survey Bolts shall be placed on platforms, the bridge walls/superstructure for ease of maintenance.
- 3.11 If there is a need to install the Survey Bolts on the existing catenary line supports, a Survey Bolt may be fitted by welding onto the steel structure of the support. Protective anti-corrosive coating should be installed at weld seam.
- 3.12 The Survey Bolts should be fitted in such a manner as to protrude from the contact line support towards the track. The Survey Bolts should be fitted in such a manner as to put a height mark, if possible, 50-100mm above the designed top of the nearest rail.
- 3.13 The position measurement of the upper surface of the Survey Bolts - absolute elevation in Baltic Elevation System (BES) and GPS, is determined from the permanent survey markers (control point monuments) established by the Contractor (See Part 1, Section 17) on ADY right-of-way every two (2) kilometres.
- 3.14 Once the absolute elevation is transferred in Baltic Elevation System (BES) onto the Survey Bolts the following data shall also be indicated against the relevant numbers of the Survey Bolts in the engineering design and then a driving log or a catalogue shall be drawn up as part of the as-built information and passed to the Engineer for the maintainers information:
- Baltic Elevation System (BES) altitude for the top of the bolt; (B)
 - GPS coordinates of the top of bolt; (G)
 - Distance to the adjacent track centreline from the Survey Bolt in mm (D);
 - Survey Bolt height in mm (V) – vertical distance from the top of the nearest rail to top of the Survey Bolt.
 - Track cant in mm from the top of the nearest rail (+ve or –ve in mm measured from the top of the nearest rail).(C)
 - Track gauge at this location (Note that some areas have widened track gauge) (W)

4. FOULING POINT MARKERS

- 4.1 For each turnout, a fouling point marker shall be installed between the turnout divergent line and the straight track.
- 4.2 The fouling point marker shall be installed at the location of the turnout beyond which rail cars, (or wagons) and locomotives must be placed to prevent being struck by trains running on the line from which the switch diverges or the straight line.
- 4.3 Fouling point markers shall be white in colour, a minimum of 300mm round or square, and 350mm deep, and shall sit in the ballast and be flush with the top of the ballast, and designed and installed by the Contractor to ADY requirements.

Lot 1 - List of curves between Sumgayit & Gil-Gil-Chay Stations

Curve No	Location	Beginning of curve (Km)	End of curve (Km)	Length of curve, m	Radius of curve, m
65	GilGil Chay - Gizilburun	2538+707	2539+356	649	550
66	GilGil Chay - Gizilburun	2540+785	2541+051	266	1935
67	GilGil Chay - Gizilburun	2542+485	2542+886	401	2160
68	GilGil Chay - Gizilburun	2542+675	2548+508	833	2138
69	Gizilburun - Siyazan	2549+715	2550+121	406	632
70	Gizilburun - Siyazan	2550+408	2550+997	589	654
71	Gizilburun - Siyazan	2552+455	2553+426	471	1065
72	Gizilburun - Siyazan	2553+491	2554+205	714	1070
73	Gizilburun - Siyazan	2554+673	2555+085	412	635
74	Gizilburun - Siyazan	2555+674	2556+271	597	1085
75	Gizilburun - Siyazan	2556+752	2557+241	489	2055
76	Gizilburun - Siyazan	2557+670	2558+040	370	665
77	Gizilburun - Siyazan	2558+633	2558+977	344	550
78	Siyazan - Zarat	2562+075	2562+334	259	1020
79	Siyazan - Zarat	2566+210	2566+710	500	1765
80	Siyazan - Zarat	2568+286	2568+581	295	1115
81	Zarat - Gilazi	2573+304	2573+708	404	2050
82	Zarat - Gilazi	2574+020	2574+078	58	3000
83	Zarat - Gilazi	2574+095	2574+153	58	3000
84	Zarat - Gilazi	2574+180	2574+238	58	3000
85	Zarat - Gilazi	2574+260	2574+318	58	3000
86	Zarat - Gilazi	2578+140	2578+198	58	3000
87	Zarat - Gilazi	2578+240	2578+298	58	3000
88	Gilazi - Sitalchay	2579+504	2579+570	66	3000
89	Gilazi - Sitalchay	2579+772	2579+862	90	3000
90	Gilazi - Sitalchay	2579+909	2579+999	90	3000
91	Gilazi - Sitalchay	2581+464	2581+532	68	3000
92	Gilazi - Sitalchay	2581+571	2581+711	140	3000
93	Gilazi - Sitalchay	2581pk730	2581+802	72	3000
94	Gilazi - Sitalchay	2582+220	2582+265	45	3000
95	Gilazi - Sitalchay	2582+294	2582+383	89	3000
96	Gilazi - Sitalchay	2582+438	2582+482	44	3000
97	Gilazi - Sitalchay	2588+828	2588+885	57	3000
98	Gilazi - Sitalchay	2588+951	2589+008	57	3000
99	Sitalchay - Yashma	2590+520	2590+609	89	3000
100	Sitalchay - Yashma	2590+614	2590+678	64	1300
101	Sitalchay - Yashma	2595+160	2595+247	87	1900
102	Sitalchay - Yashma	2595+489	2595+588	119	3000
103	Sitalchay - Yashma	2595+518	2596+482	944	3000
104	Yashma - Taglyev	2598+789	2598+836	47	3000
105	Yashma - Taglyev	2598+926	2598+974	48	3000
106	Yashma - Taglyev	2600+364	2600+559	58	3000
107	Yashma - Taglyev	2600+501	2600+559	58	3000
108	Yashma - Taglyev	2600+835	2600+899	64	3000
109	Yashma - Taglyev	2600+961	2601+086	125	1700
110	Yashma - Taglyev	2601+113	2601+187	74	3000
111	Yashma - Taglyev	2609+407	2609+431	24	3000
112	Yashma - Taglyev	2610+241	2610pk260	19	3000
113	Yashma - Taglyev	2610+337	2610+359	22	3000
114	Yashma - Taglyev	2610+735	2610+753	18	3000
115	Yashma - Taglyev	2610+936	2610+954	18	3000
116	Taglyev - Sumgayit Bash	2611+313	2611+354	41	3000
117	Taglyev - Sumgayit Bash	2611+379	2611+420	41	3000
118	Taglyev - Sumgayit Bash	2617+991	2618+083	122	600
119	Taglyev - Sumgayit Bash	2618+078	2618+377	299	625
120	Taglyev - Sumgayit Bash	2619+699	2620+020	321	585
121	Taglyev - Sumgayit Bash	2619+725	2620+042	317	570
122	Taglyev - Sumgayit Bash	2620+178	2620+221	43	1000
123	Taglyev - Sumgayit Bash	2620+224	2620+481	257	620
124	Taglyev - Sumgayit Bash	2620+298	2620+403	105	300
125	Taglyev - Sumgayit Bash	2620+615	2620+750	135	545
126	Sumgayit Bash - Guzdek	2621+009	2621+405	396	1160
127	Sumgayit Bash - Guzdek	2621+451	2621+568	117	600
128	Sumgayit Bash - Guzdek	2621+576	2621+688	110	551
129	Sumgayit Bash - Guzdek	2621+688	2621+925	237	1093
130	Sumgayit Bash - Guzdek	2622+622	2623+608	926	696
131	Sumgayit Bash - Guzdek	2622+682	2623+608	926	696

Appendix 24

ENGINEERING DESIGN ASSURANCE GATE PROCEDURE

Engineering Design Assurance Gate Procedure

1. PURPOSE

The purpose of the Engineering Design Assurance Gate Procedure is:

- 1.1 To provide progressive assurance during the engineering design stage that the objectives of the project will be achieved and that the project can progress successfully to the next stage.
- 1.2 To establish a regime where agreed products and deliverables are submitted, reviewed and accepted first-time. In the event that the submission is rejected, the Assurance Gates provide a control mechanism for resubmission; and
- 1.3 To provide clear visibility at progress checkpoints to ensure compliance with the Employer's design management milestones.

2. SCOPE

- 2.1 This procedure applies to all Lot 1 Works – From Sumgayit (km 2621 approximately) to Gil-Gil-Chay Station (km 2538,200, approximately).
- 2.2 This procedure is an Employers Requirement for Design Assurance and sets out the process to be followed to pass the Design Assurance Gates up to Definitive Design and Reference Drawings approval for each Section of the Works (Refer to **Appendix 2**).
- 2.3 All the Civil and Track Work Design shall pass through Gate 1, 2, and 3 representing the three stages of design.
- 2.4 No works on the Site shall commence for any Section until the Definitive Design has passed the Gate 3 for that Section and all the design has been 'Approved', followed by Notification provided to the Contractor by the Engineer.

3. RESPONSIBILITIES

The roles and responsibilities of the various parties is as follows:

3.1 Contractor's Definitive Design Consultant (CDDC)

- Plan, prepare and integrate design deliverables to ensure design will pass through the Gate review process.

3.2 Design Manager

- Check and ensure readiness and completeness of CDDC's evidence to satisfy the criteria for the Gate review.
- Confirm to the Gate Co-ordinator (appointed by the Engineer) that the CDDC is ready for the Gate review.

3.3 Gates Co-ordinator

- Manage the Gate review meeting schedule and convene the Gate review meeting.
- Prepare Gate Review Report for each Gate review.
- All relevant documents and records are properly maintained in the document management system.
- Prepare the Gate Certificate Notice of No Objection on successful passing of the Gate.

3.4 The Engineer

- Issue the Gate Certificate Notice of No Objection on successful passing of the Gate to the Contractor.

3.5 The Gate Review Committee

- 3.5.1 The Gate Review Committee is made up of the following senior personnel.
- Gate Chair Person (the Engineer)
 - Representative from Employer
 - Representative from Supervising Consultant (upon appointment)
 - Gate Co-ordinator
 - Safety Manager
 - Interface Manager
 - Quality Manager
 - Risk Manager
 - Construction Advisor
- 3.5.2 The quorum required for the Gate Review Committee is the Chair Person, a representative from the Employer and two others.
- 3.5.3 The Gate Chair Person shall consult with the Gate Review Committee to reach a consensus on the Gate Review decision.
- 3.5.4 The Gate Review Committee is responsible for the decision whether the CDDC has provided adequate evidence that the design has achieved the necessary criteria to proceed to the next stage of design, and that a Gate Certificate Notice of No Objection can be issued.

4. GATE PROCEDURE

4.1 Gates Overview.

- 4.1.1 A Gate is a project management technique in which a project or process is divided into stages separated by Gates. At each Gate, the continuation of the process is decided by a committee based on set criteria.
- 4.1.2 Gates are an integral part of the overall design assurance regime and enable the assembly of evidence needed for the acceptance of the Design at major milestone submissions.
- 4.1.3 Gates provide a systematic check that the project objectives are being met, interfaces are being attended to fully and properly, and that risks are being managed

4.2 Key Understanding of Gates

- 4.2.1 The Gate is NOT a design review. All design reviews, interdisciplinary, constructability, value engineering and other design reviews must be completed before the Gate.
- 4.2.2 The Gate is a review of evidence that acceptance criteria have been achieved and that the design may proceed to the next stage.
- 4.2.3 Evidence must be presented by the CDDC to demonstrate that all matters have been attended to and closed-out satisfactorily.
- 4.2.4 All design reviews must have a Code 1 (Accepted) allocation – Allocations of Code 2 (Accepted with Comments) and Code 3 (Rejected) will not be permitted and the Gate outcome will be a failure if Code 2 and Code 3 issues have not been concluded.

5. STAGED ENGINEERING DESIGN ASSURANCE GATES

5.1 Design Assurance Gates

Engineering Design Assurance Gates are held for each stage of the civil and track work design and comprise of the following:

- Gate 1 – Concept Design

- Gate 2 – Preliminary Design;
- Gate 3 – Definitive Design & Reference Drawings

5.2 Criteria for Design Assurance Gates

5.2.1 Each Gate has a pre-defined acceptance criteria

(Refer APPENDIX 24 - Table 1: Level of Evidence for Design Assurance gates 1, 2, & 3.

5.3 Gate Review Meeting Process

5.3.1 General

Each Gate Review will assess evidence against the Gate criteria. At the Gate Review Meeting the CDDC will present the evidence and the evidence will be recorded. Clarifications can be made during the Gate Review as part of the assessment process. The next stage of the project can only proceed when the Gate is passed.

5.3.2 Review Procedure

- 5.3.2.1 The CDDC presenter is required to define the scope (geographical and discipline boundaries) of the engineering design deliverables submitted to the Gate Review Committee.
- 5.3.2.2 The presenter provides evidence of deliverables that meet the required criteria, including the Employer's Requirements.
- 5.3.2.3 Evidence is then assessed by the Gate Review Committee.
- 5.3.2.4 The Gate Review Committee then decide to grant a pass or fail.
- 5.3.2.5 A Gate Pass Certificate Notice of No Objection will be issued if the Gate is passed.
- 5.3.2.6 The Gate Co-ordinator prepares the Notice of No Objection for issue by the Engineer.
- 5.3.2.7 If the Gate is failed then a return date for a new Gate review is agreed with the CDDC, and milestone consequences are assessed separately by the Engineer.

5.3.3 Criteria

Each Gate will assess the evidence against the following criteria categories (details are set out in Appendix I)

- 5.3.3.1 Meets the agreed Requirements.
- 5.3.3.2 Ensures safe construction, maintenance and operation.
- 5.3.3.3 Risks identified and mitigated/managed.
- 5.3.3.4 Design is fully co-ordinated and integrated with other sections of design work.
- 5.3.3.5 All interfaces are agreed and signed off for the required action.
- 5.3.3.6 The design is demonstrated to be constructible.
- 5.3.3.7 The design is cost effective and within the overall budget.
- 5.3.3.8 Quality is built into the design and required final quality can readily be readily achieved (QA/QC).
- 5.3.3.9 All necessary approvals from relevant Authorities have been obtained.

5.3.4 Gate Decision

If the evidence submitted at the Gate Review Meeting demonstrates the evidence meets the criteria, it will be approved by the Gate Review Committee and a Pass will be provided.

If the evidence falls short of the criteria, the design will not pass through the Gate and is therefore prevented from proceeding to the next stage. In such cases a resubmission is required and new Gate Review Meeting held. At the discretion of the Gate Review Committee, not all the evidence may need to be resubmitted but only those aspects that failed to meet the criteria.

5.3.5 Gate Review Report

The Gate Review Report is a record of the evidence submitted and presented to satisfy the criteria. The Gate Review Report will be prepared by the Gate Co-ordinator and signed off by the Gate Review Chair Person.

The Gate Review Report shall record the outcome of the Gate with all evidence attached. The Report shall be filed in the Employer’s central document management system for future reference by all parties.

APPENDIX 24 - TABLE 1 – Design Deliverables List – Gates 1, 2, & 3.

Item	Deliverable	Gate 1	Gate 2	Gate 3
1	GENERAL			
	Design Basis Statement	X	X	X
2	MEETING REQUIREMENTS			
	Employer’s Requirements verified	X	X	X
	Compliance Statements		X	X
	Design Assumption Register	X	X	X
	All design assumptions closed			X
	Drawings to confirm Works are in the Right of Way	X	X	X
	Environmental Compliance Checklist		X	X
	Schedule of 3 rd Party Undertaking & Consents	X	X	X
	List of Design Standards & Criteria	X	X	X
	Tender Design Compliance		X	X
	Design Completion Certificate			X
	Concept Design Drawings	X		
	Preliminary Design Drawings		X	
Final Drawings for Construction (Stamped by PE)			X	
3	DESIGN FOR SAFETY			
	Construction Safety Hazard Log	X	X	X
	Minutes and action tracker for hazard identification workshops		X	X
	Maintenance report		X	X
	Operations & maintenance safety hazard log		X	X
	Fire safety report		X	X
	Traffic impact assessment		X	X
	Road safety audits			X
4	MANAGEMENT OF RISK			
	Engineering Risks and mitigation actions in Risk Register	X	X	X
	Engineering risks closed			X
5	CO-ORDINATION	X	X	X
	Interface matrix	X	X	X
	Interface Control Documents signed off by interfacing parties	X	X	X
	Minutes and action tracker for Interface Design Review (IDR)	X	X	X
	Minutes and action tracker for sub-consultant design and review	X	X	X
	Combined Services Drawings		X	X
6	CONSTRUCTABILITY			
	Identification of long lead items needing advance design and works	X	X	X
	Geotechnical Interpretive Baseline Report		X	X
	Constructability Report	X	X	X
	Existing buildings and structures (including bridges) report	X	X	X
	Temporary Works Design		X	X
	Instrumentation and monitoring proposal		X	X
	Sequencing drawings showing assumed feasible construction method		X	X
	Minutes and action tracker of Constructability Reviews	X	X	X
Confirmation the design is constructible within timeframe and milestones		X	X	
7	AFFORDABILITY			
	Value Engineering Report	X	X	X

8	QUALITY			
	Design Quality Plan	X	X	X
	Detailed Materials and Workmanship Specification		X	X
	Internal QA audit details	X	X	X
9	SAFEGUARD			
	Contractor's EMP	X	X	X
	Schedule of Environmental Approvals required	X	X	X
	Environmental Sign-off by MENR			X
	Updated Land Acquisition and Resettlement Plan	X	X	X
10	OBTAINING APPROVALS			
	List of agencies requiring approvals to be given	X	X	X
	Approvals completed and sign-off			X
	Permit to work and commence construction			X

APPENDIX 25

Supplementary Information

Land Acquisition and Resettlement Plan

(soft copy is provided in DVD for Lot 1)

APPENDIX 26

Supplementary Information

Initial Environmental Examination (IEE) Report

(soft copy is provided in DVD for Lot 1)

ATTACHMENT 1

LEVEL CROSSING DETAILS

(provided in DVD for Lot 1)

ATTACHMENT 2

ANIMAL CROSSING DETAILS

(provided in DVD for Lot 1)

ATTACHMENT 3

BRIDGE DETAILS

(provided in DVD for Lot 1)

ATTACHMENT 4

CULVERT DETAILS

(provided in DVD for Lot 1)